

UNISTRUT®

General Engineering Catalog



16
No.

North American Edition



MEET MR. STRUT

Mr. Strut has symbolized Unistrut innovation for over 50 years and he's still coming up with fresh ideas and new ways to help you work easier, faster and smarter! So watch for Mr. Strut. When he's around you're never far from the Unistrut World of Support.



UNISTRUT®

The Unistrut World of Support starts with our network of Unistrut Service Centers across the nation.

The Unistrut World of Support starts with our network of Unistrut Service Centers across North America. They go far beyond providing local product inventories... by offering complete application solutions, based on experience gained from thousands of projects worldwide.

It's the kind of knowledgeable assistance that can help save time and cost now, and simplify change in the future.

Technical help? No one knows the engineering side of Unistrut support systems like your local Unistrut team. And if it's special fabrication, cutting or custom finishing you want, the pros at your local Unistrut Service Center will make it happen...quickly, efficiently, economically.

So when it's help you need, call your Unistrut Service Center—the quickest way to unlock Unistrut's World of Support.

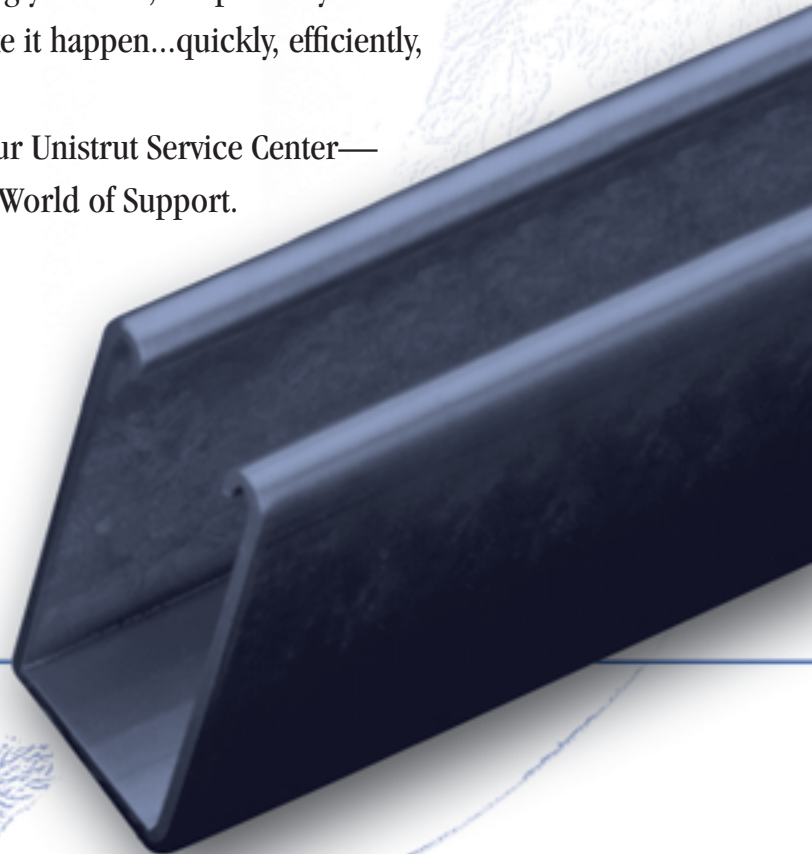
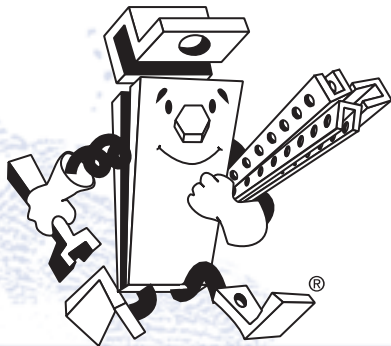



UNISTRUT

TABLE OF CONTENTS

INTRODUCTION1-20

- Unistrut Metal Framing Systems6-9
- Quality Assurance 10
- Materials and Finishes11-13
- Design Fundamentals14-15
- Conversion Factors 16
- Reference Tables and Data17-18
- Guide Specification 19
- New Products 20

1 5/8" CHANNEL21-56

- Channel Pictorial Index 22
- Channel Selection Chart 23
- Channels & Combinations24-53
- Closure Strips 54
- End Caps & Frame Caps 55
- Load Reduction Charts 56
- Bearing Loads 56

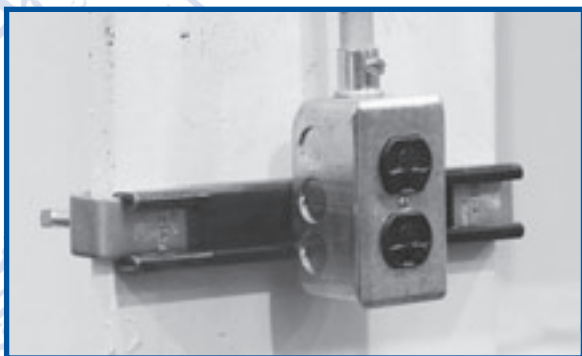

TELESTRUT® SYSTEM57-64

- Telestrut Pictorial Index58-59
- Telestrut Channels59-61
- Telestrut Connection Methods 62
- Post Bases62-63
- Cutting Chart 64

NUTS & HARDWARE65-70

- Nuts & Hardware Pictorial Index 66
- Channel Nut Loads 66
- Channel Nuts67-68
- Hardware68-70

GENERAL FITTINGS71-100

- General Fittings Pictorial Index72-73
- Design Load Data 74
- Fittings75-84
- Post Bases 84
- Brackets84-87
- Brace Fittings 88
- Beam Clamps89-95
- Trolley Assemblies 96
- Special Application Fittings97-98
- Seismic Retrofit Fittings98-100

PIPE/CONDUIT SUPPORTS101-120

- Pipe & Conduit Pictorial Index 102
- Pipe & Conduit Clamps102-105
- Unicushion® 106
- Pipe & Tubing (Cush-A-Clamps®) Clamps . .107-110
- Pipe Hangers 111
- Pipe Rollers111-112
- Pipe Brackets 113
- Pipe & Conduit Reference Data114-120

ELECTRICAL FITTINGS121-132

- Electrical Fittings Pictorial Index 122
- Electrical Fittings122-124
- Receptacles 125
- Fluorescent Fixture Hangers 125
- Electrical Accessories125-126
- Junction Boxes 126
- In-Channel Joiners 127
- Swivel Hangers 127
- Cable Entrance Tubing128-129
- Cable Entrance Fittings 130
- Electrical Technical Data131-132

CONCRETE INSERTS.....133-140

Concrete Inserts Pictorial Index..... 134
Installation & Heavy Duty Inserts.....134-135
Standard Duty & Accessories 136, 138
Light Duty..... 137
Spot Inserts..... 138
Deck Inserts..... 139
Components..... 139
Concrete Inserts Technical Data..... 140

1 1/4" FRAMING SYSTEM.....141-154

1 1/4" Framing System Pictorial Index..... 142
Channels.....143-149
Nut Selection and Load Data 150
Unistrut Nuts 150
Channel End Caps & Closure Strips..... 151
Fittings151-153
Tubing Clips..... 154
Brackets 154

1 3/16" FRAMING SYSTEM155-166

1 3/16" Framing System Pictorial Index..... 156
Channels.....157-160
Channel Nuts, Caps & Closures 161
Fittings161-165
Special Applications 165
Beam Clamps & Tubing Clips..... 166

FIBERGLASS SYSTEM.....167-182

Fiberglass Pictorial Index..... 168
Fiberglass Channel.....169-171
Fiberglass Channel Nuts & Accessories 172
Fiberglass Hardware and Accessories.....171-174
Fittings175-176
Fiberglass Post Bases 176
Fiberglass Pipe Clamps..... 177
Fiberglass Clevis Hangers..... 178
Fiberglass Beam Clamps,
Power-Rack Stanchions 179
Fiberglass Technical Data180-181
Fiberglass Sample Specifications 182

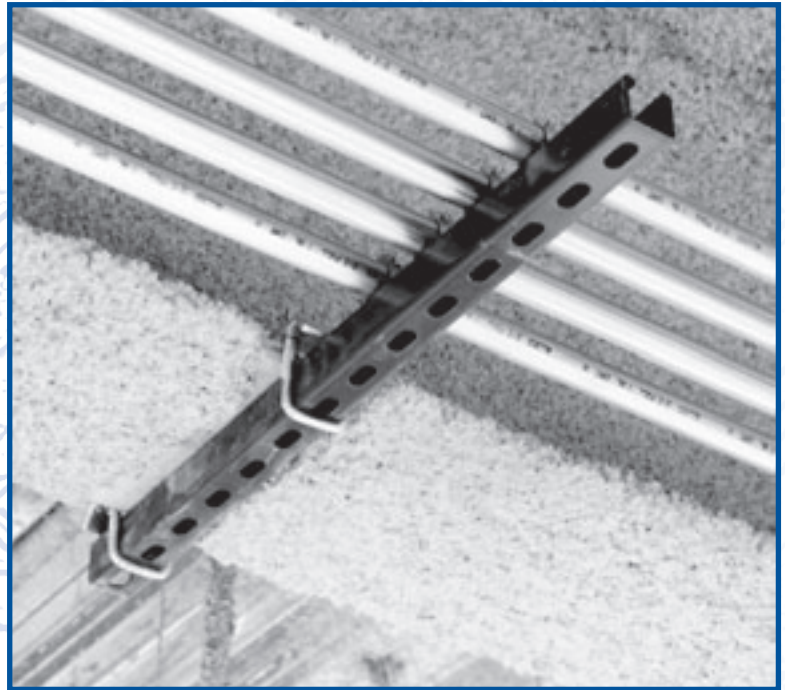

SPECIAL METALS183-188

Special Metals Pictorial Index 184
Stainless Steel 185
Stainless Steel Channel Nuts..... 186
Extruded Aluminum Channels187-188

PRIMEANGLE™189-194

PrimeAngle & Accessories 190-191
PrimeAngle Beam Loads.....192-193
PrimeAngle Column Loads..... 194

INDEX.....195-202

Part Number Index.....195-200
Keyword Index..... 201-202





Featuring The Unique Weldless Connection

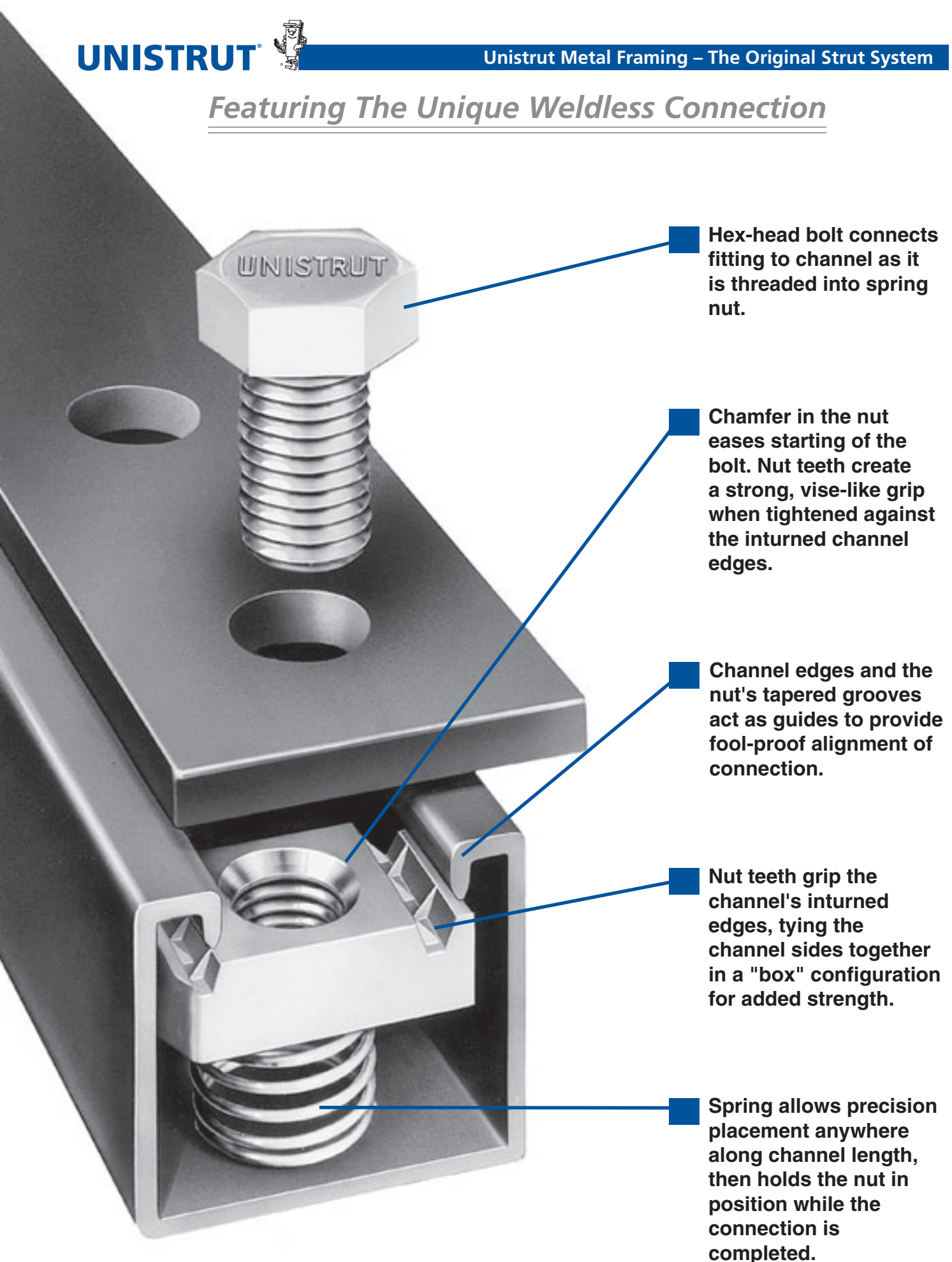

Hex-head bolt connects fitting to channel as it is threaded into spring nut.

Chamfer in the nut eases starting of the bolt. Nut teeth create a strong, vise-like grip when tightened against the inturned channel edges.

Channel edges and the nut's tapered grooves act as guides to provide fool-proof alignment of connection.

Nut teeth grip the channel's inturned edges, tying the channel sides together in a "box" configuration for added strength.

Spring allows precision placement anywhere along channel length, then holds the nut in position while the connection is completed.

Strong, Fast, Economical and Adjustable

Insert the spring nut anywhere along the continuous slotted channel. The rounded nut ends permit easy insertion.

1

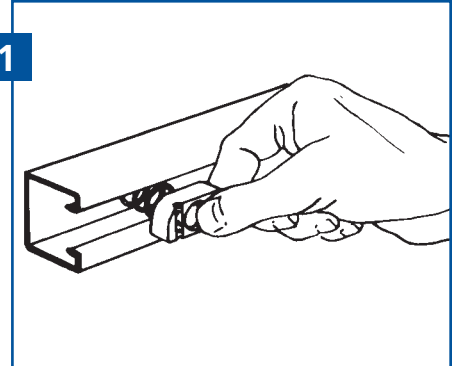

2

A 90° clockwise turn aligns the grooves in the nut with the inturned edges of the channel.

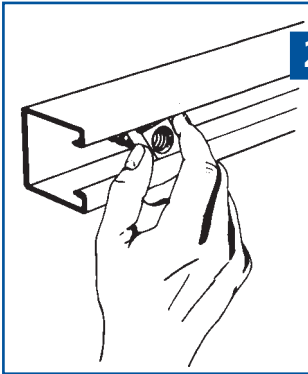

Fittings can be placed anywhere along the channel opening, permitting complete freedom of adjustment. The need for drilling holes is eliminated.

3

Insert the bolt through the fitting and into the spring nut. (See illustration 5 for end view showing the nut in place)

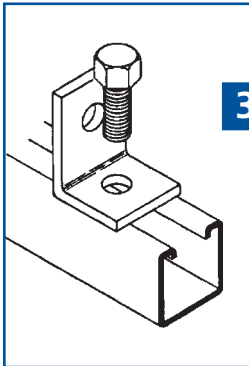

4

Additional channel sections can now be bolted to the fitting already in place by following procedure described in steps 1–3.

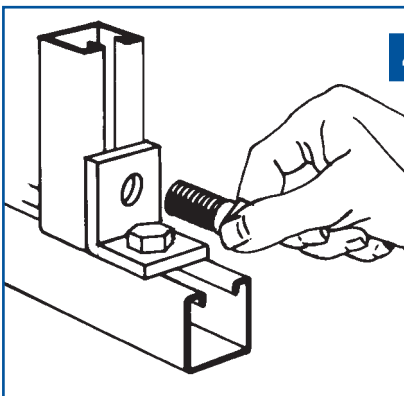

5

Tightening with a wrench locks the serrated teeth of the nut into the inturned edges of the channel, to complete a strong, vise-like connection.

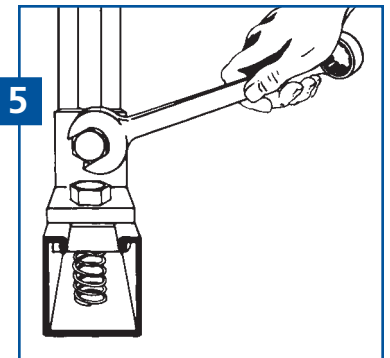

- 100% Adjustable
- 100% Reusable
- No Welding
- No Drilling
- No Special Tools



Serving Design Professionals for Over 60 Years

Unistrut products have been helping to build a better world since 1924. Used extensively in nuclear, industrial and commercial construction markets for over 75 years, Unistrut Metal Framing has set the standard for product design, quality and performance. The initial Unistrut concept — a simple spring nut and bolt connecting a fitting to a continuous slotted channel — has evolved into a comprehensive engineered building and support system.

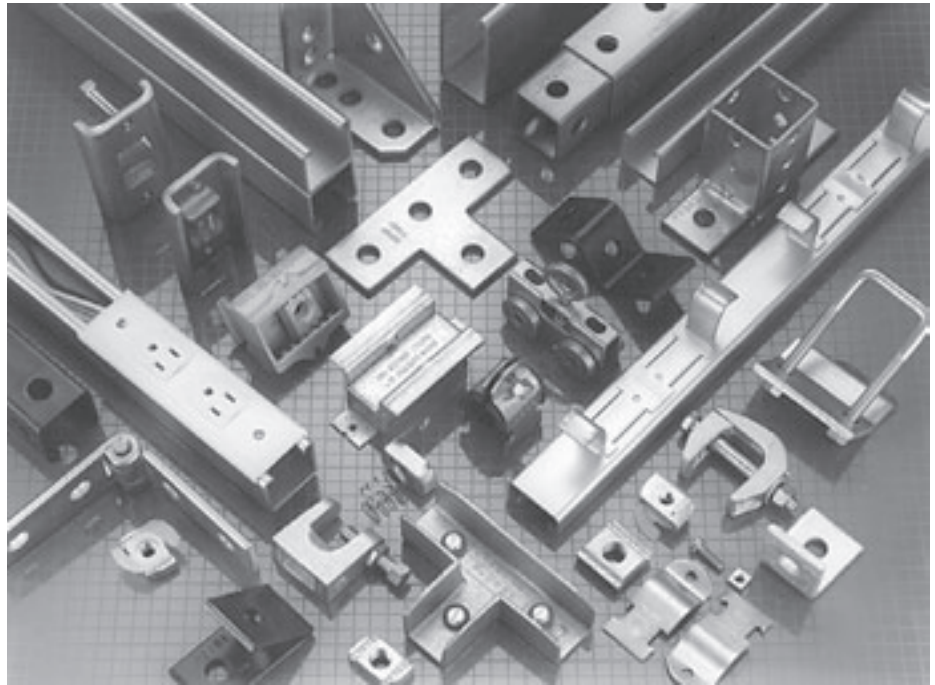

Unistrut® — The Original Metal Framing System

There is only one Unistrut Metal Framing System. It incorporates the innovative product improvements that our research and development group has created to give you the most complete and flexible support system available. Backed by our worldwide network of engineering and distribution centers, Unistrut provides customers with total-resource capability.

A North American network of Unistrut Service Centers — stocking standard Unistrut components — are located in principal cities to serve you quickly and directly. Many Service Centers are equipped to design and supply drawings for any type of metal framing application and also offer fabrication and installation services.

This catalog is a comprehensive presentation of Unistrut Metal Framing components plus technical data required by design, specification and construction professionals.

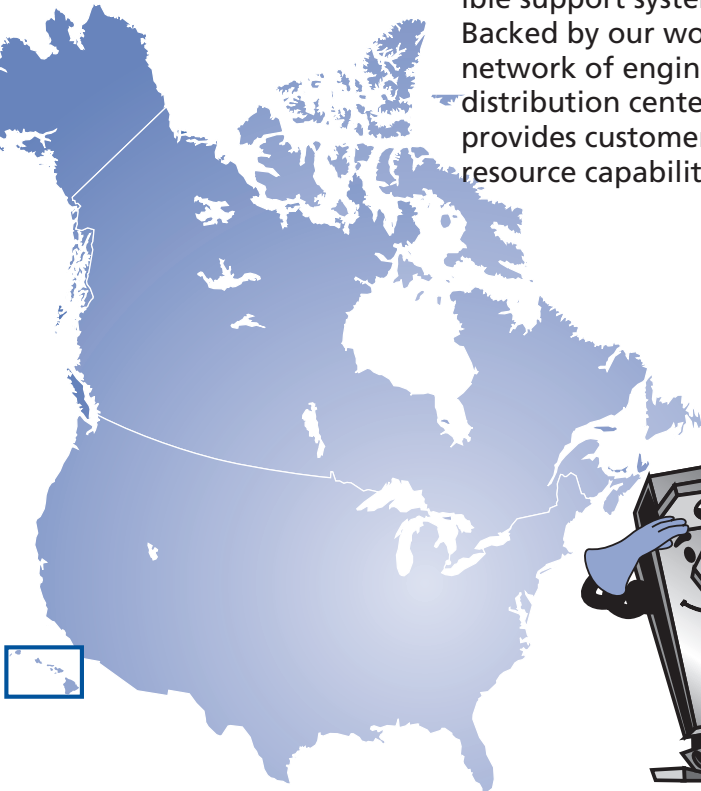

THE MOST COMPLETE METAL FRAMING SYSTEM — THREE CHANNEL-WIDTH OPTIONS

Adjustability, demountability and reusability are engineered into each of the three Unistrut channel series. Each series offers channels of varying depth and gage plus a complete line of fittings and accessories.

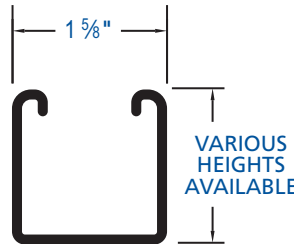
1⁵/₈" width Series Channel**1⁵/₈" (41mm) width**

Designed to carry the heaviest loads and provide the widest variety of applications, the 1⁵/₈" series has become the accepted standard for use in mechanical, electrical and general construction applications where supports and attachments must meet the highest strength requirements.

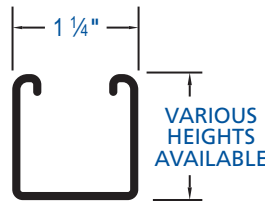
1¹/₄" width Series Channel**1¹/₄" (32mm) width**

A framing system designed for medium loads, the 1¹/₄" series is especially suitable for use in the OEM, commercial and display markets. It maintains a lightness in scale and a clean line that makes it aesthetically pleasing as well as functional.

1³/₁₆" width Series Channel**1³/₁₆" (21mm) width**

A unique half-size reduction of the 1⁵/₈" channel-width series, this smaller channel size can be used to carry light loads economically in applications such as instrumentation, retail displays and light-duty laboratory supports. It also provides the flexibility found in all Unistrut framing systems.



PRODUCT LOAD TESTING

Product testing is an important Part of Unistrut's Quality Assurance Program. We utilize our own testing facilities, as well as those of independent testing laboratories, to determine design loads with proper and adequate safety factors. These design loads are indicated, where applicable, throughout the catalog. Loads are based on AISI Specification For The Design Of Cold-Formed Steel Structural Members, 2001 Edition.

Destructive and non-destructive testing procedures are used to test for variables such as corrosion, conductivity, electro-static dissipation, ultra-violet resistance, wind resistance, dimensional accuracy, material integrity and slip resistance.

In short, if there's a specification to meet, Unistrut will develop a test to quantify and verify it. Using design properties of the Unistrut framing members, load data

given in this catalog, and/or design procedures of the American Iron & Steel Institute Specification For The Design Of Cold-Formed Steel Structural Members, 2001 Edition, it is possible to design any type of structure within the capabilities of the system.

Assemblies or connections that cannot be calculated using provisions of the AISI specifications must be established by application-specific tests.

QUALITY PROGRAM

Unistrut is committed to being the "best" in the metal framing industry. In order to meet this goal, Unistrut has adopted the philosophy of "Zero Defects and Continuous Improvement". This means on-going reviews of our manufacturing processes,

operating procedures and quality systems to find ways of improving efficiency, productivity and quality. It means establishing process controls and problem-prevention techniques to ensure that superior quality is built into every Unistrut product.

Our drive to be the best includes not just quality products, but on-time delivery and prompt resolution of customer needs and concerns. At Unistrut, quality is number one.

TRACEABILITY

Unistrut channel is stamped with a numeric code that allows traceability to the origin of the steel



MATERIAL

Framing Members

Unistrut channels and continuous inserts are accurately and carefully cold-formed to size from low carbon strip steel. One side of the channel has a continuous slot with inturned edges. Secure attachments may be made to the framing member with the use of hardened, toothed, slotted nuts which engage the inturned edges.

Raw steel shall conform to the following ASTM specifications:

| GAGE | FINISH | ASTM NO. |
|------|---------|----------------|
| 12 | GR & HG | A1011 SS GR 33 |
| | PG | A653 GR 33 |
| 14 | GR & HG | A1011 SS GR 33 |
| | PG | A653 GR 33 |
| 16 | GR & HG | A1011 SS GR 33 |
| | PG | A653 GR 33 |
| 19 | GR | A1008 |

WEIGHTS AND DIMENSIONS

Weights given for all materials are approximate shipping weights. All dimensions are subject to commercial tolerance within published specifications.

Nuts and Bolts

Unistrut nuts are made from steel bars. After all machining operations are complete, they are thoroughly case hardened. Nuts are rectangular with ends shaped to permit a quarter turn clockwise in the framing member after insertion through the slotted opening in the channel. Two toothed grooves in the top of the nut engage the inturned edges of the channel and, after bolting operations are completed, will prevent any movement of the bolt and nut within the framing member. All bolts and nuts have Unified coarse screw threads. The standard framing nut is 1/2" and conforms to ASTM Specification A1011 SS GR 33 (material only). Screws conform to SAE J429 GR .

Fittings

Unistrut fittings, unless noted otherwise, are punch-press made from hot rolled, pickled and oiled steel plates, strip or coil, and conform to ASTM specifications A575, A576, A635 or A36. The fitting steel also meets the physical requirement of ASTM A1011 SS GR 33. The pickling of the steel produces a smooth surface free from scale.

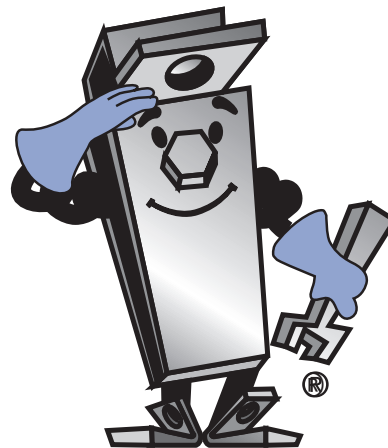

WE RESERVE THE RIGHT TO MAKE SPECIFICATION CHANGES WITHOUT NOTICE.

WHILE EVERY EFFORT HAS BEEN MADE TO ASSURE THE ACCURACY OF INFORMATION CONTAINED IN THIS CATALOG AT THE TIME OF PUBLICATION, WE CANNOT ACCEPT RESPONSIBILITY FOR INACCURACIES RESULTING FROM UNDETECTED ERRORS OR OMISSIONS.

THE BLUE COLOR USED ON UNISTRUT COMPONENTS ILLUSTRATED IN THIS CATALOG IS FOR GRAPHIC ENHANCEMENT ONLY, AND DOES NOT REPRESENT ACTUAL PRODUCT COLOR.



Perma-Green® III

The performance of Unistrut's Perma-Green III far exceeds that of conventional finishes. And compared to competitive "high-performance" coatings, Perma-Green III provides superior resistance to chalking, checking and fading and is far less vulnerable to common acidic atmospheres, solvents and alkalis.

Just as important, Perma-Green III is the result of an environmentally neutral process that virtually eliminates the toxic metals commonly found in competitive paint-based finishes.

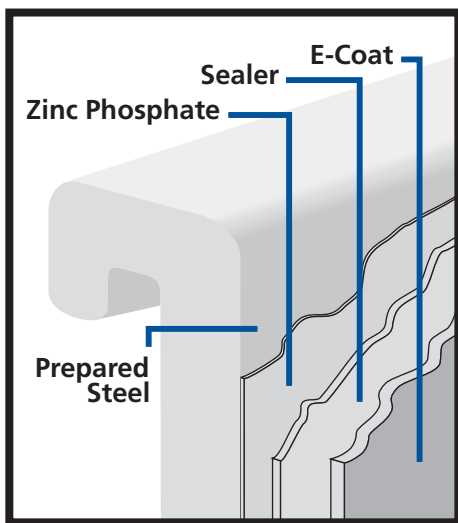
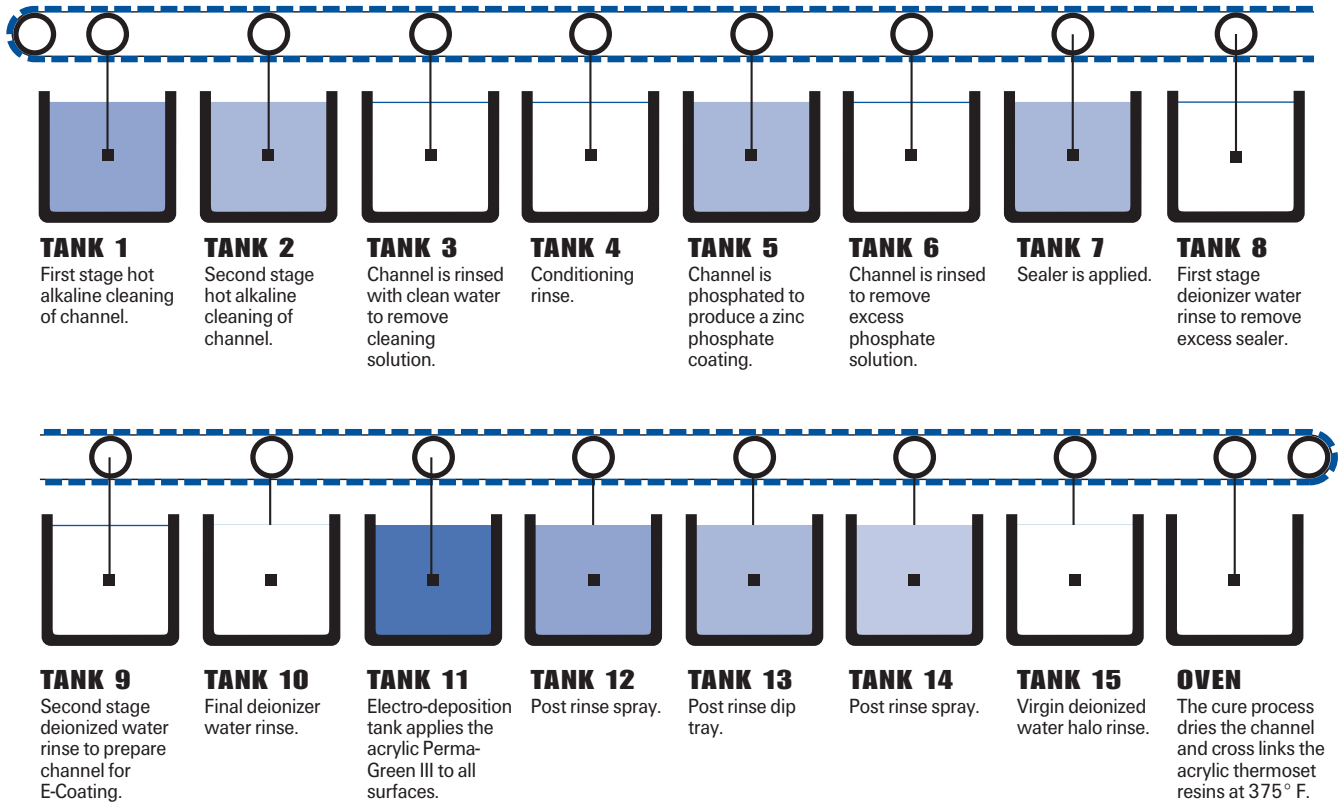

PERMA-GREEN® III (GR) TECHNICAL DATA

STEEL SUBSTRATE PREPARATION

Ten stage continuous cleaning, phosphate process.
Substrate after "prep": sealed zinc phosphate conversion coating.

COATING

Thermoset acrylic
Color:
Federal Highway Green
Color Tolerance Chart
PR Color No. 4
Hardness: 2H.
Coating Process:
Cathodic Electrodeposition.

PERFORMANCE

Salt Spray:
Scribed: exceeds 400 hours per ASTM B117. (1/8" creep)
Unscribed: exceeds 600 hours per ASTM B117. (6% red rust)
Chalk:
Nominal at 1,000 hours per weatherometer G-23 test.
Checking:
None at 1,000 hours per weatherometer G-23 test.
Fade:
Less than 50% compared to standard epoxy E.C. coatings.

ENVIRONMENTAL ISSUES

Formulated as a "heavy metal"-free coating (trace elements only).
Outgassing in service: essentially none at 350°F for 24 hours.

PLAIN (PL)

Plain finish designation means that the channel retains the oiled surface applied to the raw steel during the rolling process. The fittings have the original oiled surface of the bar-stock material.

**Pregalvanized Zinc (PG)
ASTM A653**

Pregalvanized steel is zinc coated by a hot dip process. Steel strip from a coil is fed through a continuous zinc coater which cleans, fluxes and coats the steel with molten zinc. After cooling, the steel is recoiled.

The pregalvanized zinc coating conforms to a G-90 thickness designation per ASTM A653. The zinc thickness is .75 MIL or .45 oz./sq. ft. of surface area.

This coating is offered on Unistrut channel and tubing and is a well-proven, time-tested performer for indoor and outdoor applications. For severe corrosion applications, hot dip galvanizing, as described below, is a good alternative.

**HOT DIP GALVANIZED (HG)
ASTM A123 OR A153**

In hot dip galvanizing, the finished part is immersed in a bath of molten zinc. This method results in complete zinc coverage and a thicker coating than pregalvanized or plated zinc.

The zinc coating is typically 2.6 MIL or 1.5 oz./sq. ft. of surface area.

This is the coating of choice for applications where severe corrosion is a design factor.

SPECIAL COATING

When specific applications require other than standard available finishes, special finishes can be supplied per customer requirements.

**Electroplated Zinc (EG)
ASTM B633, Type III SC1 or SC3**

In the electroplating process, the part to be zinc coated is immersed in a solution of zinc ions. An electric current causes the zinc to be deposited on the part.

SC1 (mild) has a Zinc coating of 0.2 and is recommended for dry indoor use. SC1 is the standard finish thickness.

SC3 (Severe) has a Zinc coating of 0.5 mill and is the standard finish thickness only on UL Listed raceway products.

**Perma-Gold (ZD)
ASTM B633, Type II SC1 or SC3**

Similar to the EG process except in a yellow color.

SC1 (mild) has a Zinc coating of 0.2 and is recommended for dry indoor use. SC1 is the standard finish thickness

SC3 (Severe) has a Zinc coating of 0.5 mill and is the standard finish thickness only on UL Listed raceway products.

Zinc Coating

Unistrut products are available in four types of zinc coatings:

- Electroplated (EG)
- Perma-Gold (ZD)
- Pregalvanized (PG)
- Hot Dip Galvanized (HG).

Zinc offer two types of protection:

- Barrier: The zinc coating protects the steel substrate from direct contact with the environment.
- Sacrificial: The zinc coating will protect scratches, cut edges, etc. through an anodic sacrificial process.

The service life of zinc coating is directly related to the zinc coating thickness as shown below.

| Comparison of Zinc Finishes | |
|-----------------------------|----------------|
| Finish | Zinc Thickness |
| Hot Dip Galvanized | 2.6 MIL |
| Pre-galvanized | 0.75 MIL |
| Electro-Galvanized (SC1) | 0.2 MIL |
| Electro-Galvanized (SC3) | 0.5 MIL |
| Perma-Gold (SC1) | 0.2 MIL |
| Perma-Gold (SC3) | 0.5 MIL |

As shown in the graph, when the zinc coating is double, the service life is double under most conditions.

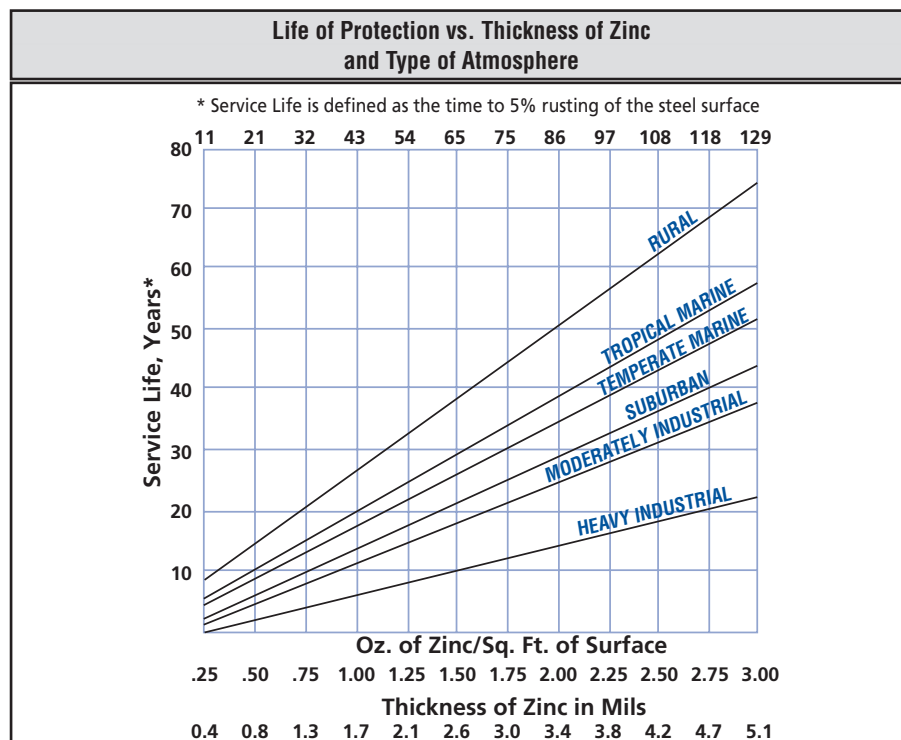



BEAMS

Beams are structural members loaded at right angles (perpendicular) to their length. Most beams are horizontal and subjected to gravity or vertical loads, e.g. a shelf support. However a vertical member can act as a beam under certain conditions, such as a curtain wall mullion subjected to wind loading. The bending moment developed in a beam is dependent on:

- (a) the amount of load applied,
- (b) the type of loading applied, and
- (c) the support conditions.

BEAM LOADING - POINT LOAD

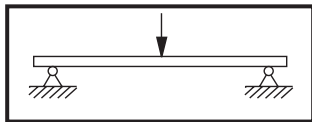

A load concentrated onto a very small length of the beam is a point load.

BEAM LOADING - UNIFORM LOAD

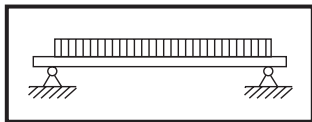

A load spread evenly over a relatively long length of the beam is a uniform load.

Point and uniform loads can be placed on a beam in any combination. A series of point loads can approximate a uniform loading. The load charts and tables are based on a uniform load unless identified otherwise.

SUPPORT CONDITIONS - SIMPLE BEAM

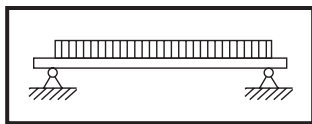

A simple beam has supports that prevent movement left and right, or up and down, but do not restrain the beam from rotating at the supports into a natural deflected curve. Most Unistrut Metal Framing connections produce simple beams. The load charts and tables are based on simple beams unless identified otherwise.

SUPPORT CONDITIONS - CONTINUOUS BEAM

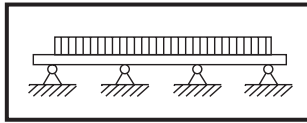

Any simple beam that is supported at one or more intermediate points is a continuous beam. A mezzanine joist that passes over three or more columns is an example of a continuous beam.

SUPPORT CONDITIONS - FIXED-END BEAM

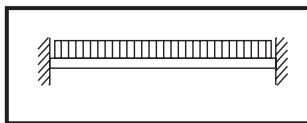

Supports that prevent the beam from

rotating into a natural deflected curve produce a fixed-end beam. A welded end connection to very rigid support produces a fixed-end beam.

SUPPORT CONDITIONS - CANTILEVER BEAM

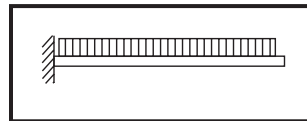

A cantilever beam is a fixed-end beam that is supported at one end only, while the other end is unsupported. Unistrut brackets are examples of cantilever beams.

DEFLECTION

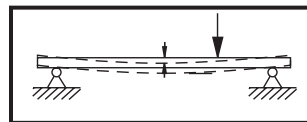

All beams deflect under load. The amount of deflection is dependent on

- (a) the amount of load,
- (b) the support conditions,
- (c) the stiffness of the beam's cross-sectional shape, and
- (d) the stiffness of the beam material.

The stiffness of the beam's cross-sectional shape is measured by its "Moment Of Inertia" or "I". The larger a beam's "I", the stiffer it is and the less it will deflect. A beam's "I" can change for each major axis. The "I" of both major axes (I 1-1 and I 2-2) are provided.

The stiffness of a beam's material is measured by its "Modulus of Elasticity" or "E". The larger a material's "E", the stiffer it is and the less it deflects. For example, steel is about three times stiffer than aluminum and as a result, deflects only one-third as much. Do not confuse stiffness with strength. Two materials may have identical strengths yet still have different "E's". A high-strength aluminum may be as strong as steel and still deflect three times as much.

The load charts and tables give calculated deflections for the loads shown. In many cases, a final design will be determined by the maximum deflection, not the maximum load.

BENDING MOMENT

Is it strong enough? This is the final consideration for any beam. A beam must not only hold up the anticipated loads, but must also have sufficient additional capacity to safely hold unforeseen variations in applied loads and material strengths. This additional capacity is called a safety factor and is usually regulated by the various design codes and standards. A beam's strength is usually measured by an allowable bending moment or an allowable stress. The traditional approach is the allowable stress method, where a beam is determined to have a maximum allowable stress (in pounds per square inch) which is not to be exceeded.

The approach of the current AISI "Specification For The Design Of Cold-Formed Steel Structural Members" is to use a maximum allowable bending moment (in inch-pounds) which is not to be exceeded. Bending moment divided by a beam's section modulus or "S" equals stress.

COLUMNS

Columns are structural members that are loaded parallel to their length. Most columns are vertical and are used to carry loads from a higher level to a lower level. However any member subjected to compression loads, such as a diagonal or prop brace, is a column.

A column fails by “buckling”, which is a sudden loss of straightness and subsequent collapse. Allowable column load is dependent on:

- (a) the length of column,
- (b) the type of loading,
- (c) the support conditions, and
- (d) the column’s cross-sectional shape and material.

COLUMN LENGTH

The column length is measured from braced point to braced point. A braced point is where the column is restrained from lateral movement (translation) in all directions.

COLUMN LOADING – CONCENTRIC LOADING

Loads applied to the center of gravity of the column cross-section are considered concentric. A beam that passes over and rests on the top of a column is an example of concentric loading.

COLUMN LOADING – ECCENTRIC LOADING

Any load which is not concentric is eccentric. The amount of eccentricity (in inches) has a major effect on the load-carrying capacity of any particular column. A load that is transmitted to a Unistrut Metal Framing column using a standard fitting bolted to the slot face is considered eccentric.

The load tables give allowable loads for both concentric (loaded at C.G.) and certain eccentric (loaded at slot face) loading. Allowable loads for other eccentric loading must be determined by a qualified design professional.

SUPPORT CONDITIONS

Based on the support conditions, an appropriate “K” value is selected. This “K” value, which mathematically describes the column end conditions, is used in the column design equations. The most common support condition combinations are as follows:

SUPPORT CONDITIONS - FIXED TOP – FIXED BOTTOM

Both ends are restrained against rotation and lateral movement (translation).

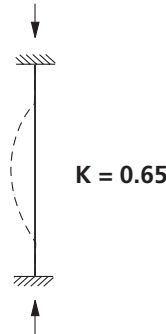

SUPPORT CONDITIONS - PINNED TOP – FIXED BOTTOM

The top is restrained against lateral movement (translation) but is allowed to rotate. The bottom is restrained against rotation and lateral movement.

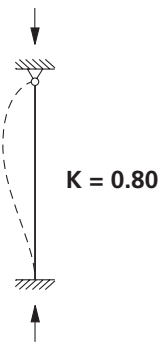

This is a common support condition and is used to construct the allowable column load applied at the Slot Face tables.

SUPPORT CONDITIONS - PINNED TOP – PINNED BOTTOM

Both ends are restrained against lateral movement (translation) but, are allowed to rotate.

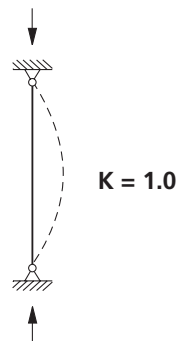

SUPPORT CONDITIONS - FIXED / FREE TOP – FIXED BOTTOM

The top is restrained against rotation but is allowed to move laterally. The bottom is restrained against rotation and lateral movement (translation).

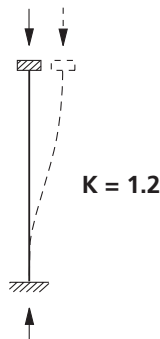

CROSS-SECTIONAL SHAPE

The cross-sectional shape of a column member determines the value of its “Radius of Gyration” or “r”. In general, a member with a large “r” makes a better column than a member with a small “r”. Each axis of a column has a different “r”. Typically the axis with the smallest “r” determines the final design.

BOLT TORQUE

Bolt torque values are given to ensure the proper connection between Unistrut Metal Framing components. It is important to understand that there is a direct, but not necessarily consistent, relationship between bolt torque and tension in the bolt. Too much tension in the bolt can cause it to break or crush the component parts. Too little tension in the bolt can prevent the connection from developing its full load capacity. The torque values given have been developed over many years of experience and testing.

| Bolt Torque | | | | | | |
|--------------------------|----------|-----------|----------|----------|-----------|-----------|
| BOLT SIZE | 1/4" -20 | 5/16" -18 | 3/8" -16 | 1/2" -13 | 5/8" -11 | 3/4" -10 |
| Rec. Torque Ft/Lbs (N·m) | 6 (8) | 11 (15) | 19 (26) | 50 (68) | 100 (136) | 125 (170) |
| Max Torque Ft/Lbs (N·m) | 7 (9) | 15 (20) | 25 (34) | 70 (95) | 125 (170) | 135 (183) |

These are based on using a properly calibrated torque wrench with a clean dry (non-lubricated) Unistrut fitting, bolt and nut. A lubricated bolt or nut can cause extremely high tension in the connection and may lead to bolt failure. It must be noted that the accuracy of commercial torque wrenches varies widely and it is the responsibility of the installer to ensure that proper bolt torque has been achieved.







UNIT CONVERSIONS

| To Convert From | English To Metric To | Multiply By |
|--|--------------------------------------|---------------|
| Length | | |
| Inch [in] | Millimeter [mm] | 25.400 000 |
| Foot [ft] | Meter [m] | 0.304 800 |
| Yard [yd] | Meter [m] | 0.914 400 |
| Mile [mi] (U.S. Statute) | Kilometer [km] | 1.609 347 |
| Area | | |
| Square Inch [in ²] | Square Millimeter [mm ²] | 645.16 |
| Square Foot [ft ²] | Square Meter [m ²] | 0.092 903 |
| Square Yard [yd ²] | Square Meter [m ²] | 0.836 127 |
| Square Mile [mi ²] (U.S. Statute) | Square Kilometer [km ²] | 2.589 998 |
| Acre | Square Meter [m ²] | 4046.873 |
| Acre | Hectare | 0.404 687 |
| Volume | | |
| Cubic Inch [in ³] | Cubic Millimeter [mm ³] | 16387.06 |
| Cubic Foot [ft ³] | Cubic Meter [m ³] | 0.028 317 |
| Cubic Yard [yd ³] | Cubic Meter [m ³] | 0.764 555 |
| Gallon [gal] (U.S. Liquid) | Litre [l] | 3.785 412 |
| Quart [qt] (U.S. Liquid) | Litre [l] | 0.946 353 |
| Mass | | |
| Ounce (Avoirdupois) [oz] | Gram [g] | 28.349 520 |
| Pound (Avoirdupois) [lb] | Kilogram [kg] | 0.453 592 |
| Short Ton | Kilogram [kg] | 907.185 |
| Force | | |
| Ounce-Force | Newton [N] | 0.278 014 |
| Pound-Force [lbf] | Newton [N] | 4.448 222 |
| Bending Moment | | |
| Pound-Force-Inch [lbf-in] | Newton-Meter [N-m] | 0.112 985 |
| Pound-Force-Foot [lbf-ft] | Newton-Meter [N-m] | 1.355 818 |
| Pressure, Stress | | |
| Pound-Force per Square Inch [lbf/in ²] | Kilopascal [kPa] | 6.894 757 |
| Foot of Water (39.2 F) | Kilopascal [kPa] | 2.988 980 |
| Inch of Mercury (32 F) | Kilopascal [kPa] | 3.386 380 |
| Energy, Work, Heat | | |
| Foot-Pound-Force [ft-lbf] | Joule [J] | 1.355 818 |
| British Thermal Unit [Btu] | Joule [J] | 1055.056 |
| Calorie [cal] | Joule [J] | 4.186 800 |
| Kilowatt Hour [kW-h] | Joule [J] | 3,600,000 |
| Power | | |
| Foot-Pound-Force /Second [ft-lbs/s] | Watt [W] | 1.355 818 |
| British Thermal Unit /Hour [Btu/h] | Watt [W] | 0.293 071 |
| Horsepower [hp] (550 Ft. Lbf/s) | Kilowatt [kW] | 0.745 700 |
| Angle | | |
| Degree | Radian [rad] | 0.017 453 |
| Temperature | | |
| Degree Fahrenheit [°F] | Degree Celsius [°C] | (F° - 32)/1.8 |



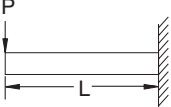

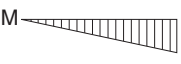
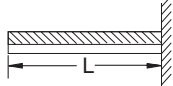
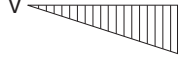
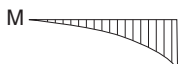
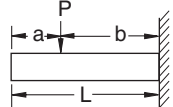
| To Convert From | Metric to English To | Multiply By |
|--------------------------------------|--|--------------------|
| Length | | |
| Millimeter [mm] | Inch [in] | 0.039 370 |
| Meter [m] | Foot [ft] | 3.280 840 |
| Meter [m] | Yard [yd] | 1.093 613 |
| Kilometer [km] | Mile [mi] (U.S. Statute) | 0.621 370 |
| Area | | |
| Square Millimeter [mm ²] | Square Inch [in ²] | 0.001550 |
| Square Meter [m ²] | Square Foot [ft ²] | 10.763 915 |
| Square Meter [m ²] | Square Yard [yd ²] | 1.195 991 |
| Square Kilometer [km ²] | Square Mile [mi ²] (U.S. Statute) | 0.386 101 |
| Square Meter [m ²] | Acre | 0.000 247 |
| Hectare | Acre | 2.471 046 |
| Volume | | |
| Cubic Millimeter [mm ³] | Cubic Inch [in ³] | 0.000061 |
| Cubic Meter [m ³] | Cubic Foot [ft ³] | 35.314 662 |
| Cubic Meter [m ³] | Cubic Yard [yd ³] | 1.307 950 |
| Litre [l] | Gallon [gal] (U.S. Liquid) | 0.264 172 |
| Litre [l] | Quart [qt] (U.S. Liquid) | 1.056 688 |
| Mass | | |
| Gram [g] | Ounce (Avoirdupois) [oz] | 0.035 274 |
| Kilogram [kg] | Pound (Avoirdupois) [lb] | 2.204 624 |
| Kilogram [kg] | Short Ton | 0.00110 |
| Force | | |
| Newton [N] | Ounce-Force | 3.596 941 |
| Newton [N] | Pound-Force [lbf] | 0.224 809 |
| Bending Moment | | |
| Newton-Meter [N-m] | Pound-Force-Inch [lbf-in] | 8.850 732 |
| Newton-Meter [N-m] | Pound-Force-Foot [lbf-ft] | 0.737 562 |
| Pressure, Stress | | |
| Kilopascal [kPa] | Pound-Force per Square Inch [lbf/in ²] | 0.145 038 |
| Kilopascal [kPa] | Foot of Water (39.2 F) | 0.334 562 |
| Kilopascal [kPa] | Inch of Mercury (32 F) | 0.295 301 |
| Energy, Work, Heat | | |
| Joule [J] | Foot-Pound-Force [ft-lbf] | 0.737 562 |
| Joule [J] | British Thermal Unit [Btu] | 0.000948 |
| Joule [J] | Calorie [cal] | 0.238 846 |
| Joule [J] | Kilowatt Hour [kW-h] | 2.78 ⁻⁷ |
| Power | | |
| Watt [W] | Foot-Pound-Force /Second [ft-lbs/s] | 0.737 562 |
| Watt [W] | British Thermal Unit /Hour [Btu/h] | 3.412 142 |
| Kilowatt [kW] | Horsepower (550 Ft. Lbf/s) [hp] | 1.341 022 |
| Angle | | |
| Radian [rad] | Degree | 57.295 788 |
| Temperature | | |
| Degree Celsius [°C] | Degree Fahrenheit [°F] | 1.8xC°+32 |

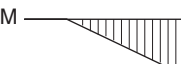
BEAM SUPPORT CONDITIONS



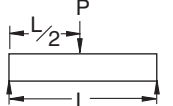

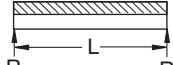

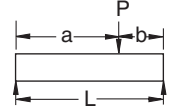
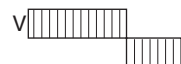
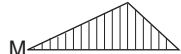

Cantilever Beams

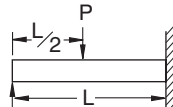
| | | |
|---|---|---|
|  <p> $V_{max.} = P$ $M_{max.} = PL$ $\Delta_{max.} = \frac{PL^3}{3EI}$ </p>   |  <p> $V_{max.} = W$ $M_{max.} = \frac{WL}{2}$ $\Delta_{max.} = \frac{WL^3}{8EI}$ </p>   |  <p> $V_{max.} = P$ $M_{max.} = Pb$ $\Delta_{max.} = \frac{Pb^2(3L-b)}{6EI}$ </p>   |
|---|---|---|





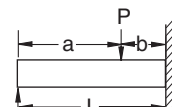
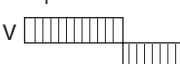

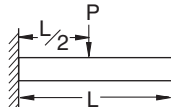

Simple Beams

| | | |
|--|--|--|
|  <p> $R = \frac{P}{2}$ $V_{max.} = \frac{P}{2}$ $M_{max.} = \frac{PL}{4}$ $\Delta_{max.} = \frac{PL^3}{48EI}$ </p>   |  <p> $R = \frac{W}{2}$ $V_{max.} = \frac{W}{2}$ $M_{max.} = \frac{WL}{8}$ $\Delta_{max.} = \frac{5WL^3}{384EI}$ </p>   |  <p> $R_1 = \frac{Pb}{L}$ $R_2 = \frac{Pa}{L}$ $V_{max.} = \frac{Pa}{L}$ $M_{max.} = \frac{Pab}{L}$ $\Delta_{max.} = \frac{Pab(a+2b)}{27EI} \sqrt{3a(a+2b)}$ </p>   |
|--|--|--|

Beams Fixed At One End & Supported At The Other

| | | |
|---|---|--|
|  <p> $R_1 = \frac{5P}{16}$ $V_{max.} = \frac{11P}{16}$ $M_{max.} = \frac{3PL}{16}$ $\Delta_{max.} \text{ at } x = 0.447L$ $\Delta_{max.} = 0.009317 \frac{PL^3}{EI}$ </p>   |  <p> $R_1 = \frac{3W}{8}$ $V_{max.} = \frac{5W}{8}$ $M_{max.} = \frac{WL}{8}$ $\Delta_{max.} \text{ at } x = 0.4215L$ $\Delta_{max.} = \frac{WL^3}{185EI}$ </p>   |  <p> $R_1 = \frac{Pb^2}{2L^3}(a+2L)$ $R_2 = \frac{Pa}{2L^3}(3L^2-a^2)$ $M \text{ at point of load} = R_1a$ $M \text{ at fixed end} = \frac{Pab}{2L^3}(a+L)$ </p>   |
|---|---|--|

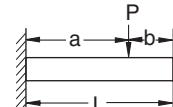
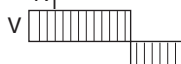
Beams Fixed At Both Ends

| | | |
|---|--|---|
|  <p> $V_{max.} = \frac{P}{2}$ $M_{max.} = \frac{PL}{8}$ $\Delta_{max.} = \frac{PL^3}{192EI}$ </p>   |  <p> $V_{max.} = \frac{W}{2}$ $M_{max.} = \frac{WL}{12}$ $\Delta_{max.} = \frac{WL^3}{384EI}$ </p>   |  <p> $R_1 = \frac{Pb^2}{L^3}(3a+b)$ $R_2 = \frac{Pa^2}{L^3}(a+3b)$ $M_1 = \frac{Pab^2}{L^2}$ $M_2 = \frac{Pa^2b}{L^2}$ </p>   |
|---|--|---|

R – Reaction
 M – Moment
 P – Concentrated Load







W – Total Uniform Load
 V – Shear
 L – Length

Δ – Deflection
 E – Modulus of Elasticity
 I – Moment of Inertia

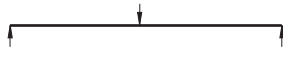
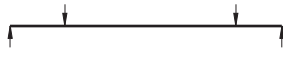
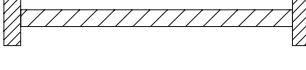

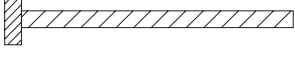
CONVERSION FACTORS FOR BEAMS WITH VARIOUS STATIC LOADING CONDITIONS

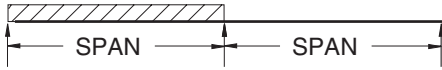
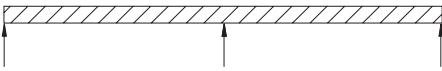
All Beam Load tables are for single-span (simple) beams supported at the ends. These can be used in the majority of the cases. However, there are times when it is necessary to know what happens with other loading and support conditions. Some common arrangements are shown below. Simply multiply the values from the Beam Load tables by factors given below

| Load and Support Condition | | Load Factor | Deflection Factor |
|--|--|-------------|-------------------|
| 1. Simple Beam, Uniform Load |  | 1.00 | 1.00 |
| 2. Simple Beam, Concentrated Load at Center |  | .50 | .80 |
| 3. Simple Beam, Two Equal Concentrated Loads at 1/4 pts |  | 1.00 | 1.10 |
| 4. Beam Fixed at Both Ends, Uniform Load |  | 1.50 | .30 |
| 5. Beam Fixed at Both Ends, Concentrated Load at Center |  | 1.00 | .40 |
| 6. Cantilever Beam, Uniform Load |  | .25 | 2.40 |
| 7. Cantilever Beam, Concentrated Load at End |  | .12 | 3.20 |
| 8. Continuous Beam, Two Equal Spans, Uniform Load on One Span |  | 1.30 | .92 |
| 9. Continuous Beam, Two Equal Spans, Uniform Load on Both Ends |  | 1.00 | .42 |
| 10. Continuous Beam, Two Equal Spans, Concentrated Load at Center of One Span |  | .62 | .71 |
| 11. Continuous Beam, Two Equal Spans, Concentrated Load at Center of Each Span |  | .67 | .48 |

EXAMPLE I:

Determine load and deflection of a P 1000 beam continuous over one support and loaded uniformly on one span.

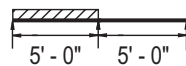

SOLUTION:

- A. From load table for P1000 on page 25 load for a 5'-0" span is 680# and deflection is .35".
- B. Multiply by factors from Table above.
Load = 680# x 1.30 = 884#
Deflection = .35" x .92 = .32"

EXAMPLE II

Determine load and deflection of a P 5500 cantilever beam with a concentrated load on the end.

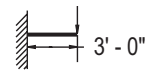

SOLUTION:

- A. From load table P5500 on page 52 load for a 3'-0" span is 2180# and deflection is .09".
- B. Multiply by factors from Table above.
Load = 2180# x .12 = 262#
Deflection = .09" x 3.20 = .29"

PART I - GENERAL**1.01 SCOPE OF WORK**

- A. Provide all Unistrut Metal Framing material, fittings and related accessories (Strut System) as indicated on the Contract Drawings.
- B. Provide all labor, supervision, engineering, and fabrication required for installation of the Strut System in accordance with the Contract Drawings and as specified herein.
- C. Related work specified elsewhere.

1.02 QUALITY ASSURANCE

- A. Manufacturer's qualifications:
 - 1. The manufacturer shall not have had less than 10 year's experience in manufacturing Strut Systems.
 - 2. The manufacturer must certify in writing all components supplied have been produced in accordance with an established quality assurance program.
- B. Installer's qualifications:
 - 1. Installer must be a Unistrut trained manufacturer's authorized representative/installer with not less than 5 years experience in the installation of Strut Systems of this size and conformation.
 - 2. All Strut System components must be supplied by a single manufacturer.
- C. Standards:
 - 1. Work shall meet the requirements of the following standards:
 - a. Federal, State and Local codes.
 - b. American Iron and Steel Institute (AIS) Specification for the Design of Cold-Formed Steel Structural Members 2001 Edition.
 - c. American Society for Testing And Materials (ASTM).

1.03 SUBMITTALS

- A. Structural Calculations and Shop Drawings
 - 1. Submit structural calculations for approval by the project engineer. Calculations may include, but are not limited to:
 - a. Description of design criteria.
 - b. Stress and deflection analysis.
 - c. Selection of Unistrut framing members, fittings, and accessories.
 - 2. Submit all shop/assembly drawings necessary to completely install the Strut System in compliance with the Contract Drawings.
 - 3. Submit all pertinent manufacturers published data.

1.04 PRODUCT DELIVERY, STORAGE, AND HANDLING

- A. All material is to be delivered to the work site in original factory packaging to avoid damage to the finish.
- B. Upon delivery to the work site, all components shall be protected from the elements by a shelter or other covering.

1.05 GUARANTEE

- A. Separate guarantees shall be issued from the erector and manufacturer, valid for a period of 1 year, against any defects that may arise from the installation or manufacture of the Strut System components.

PART 2 - PRODUCTS**2.01 ACCEPTABLE MANUFACTURERS**

- A. All Strut System components shall be as manufactured by UNISTRUT CORPORATION or approved equal as determined by the Architect or Engineer of record in writing 10 days prior to bid date.

2.02 MATERIALS

- A. All channel members shall be fabricated from structural grade steel conforming to one of the following ASTM specifications: A 1011 SS GR 33, A 653 GR 33.
- B. All fittings shall be fabricated from steel conforming to one of the following ASTM specifications: A 575, A 576, A 36 or A 635.
- C. Substitutions
 - Any substitutions of product or manufacturer must be approved in writing ten days prior to bid date, by Architect or Engineer of record.

2.03 FINISHES

- A. Strut System components shall be finished in accordance with one of the following standards:
 - 1. PERMA-GREEN® III (GR)
 - Rust inhibiting acrylic enamel paint applied by electro-deposition, after cleaning and phosphating, and thoroughly baked. Color is per Federal Highway Green, Color Tolerance Chart PR Color No. 4. Finish to withstand minimum 400 hours salt spray when tested in accordance with ASTM B117.
 - 2. ELECTRO-GALVANIZED (EG)
 - Electrolytically zinc coated per ASTM B 633 Type III SC 1

- 3. PRE-GALVANIZED (PG)
 - Zinc coated by hot-dipped process prior to roll forming. The zinc weight shall be G90 conforming to ASTM A 653.
- 4. HOT-DIPPED GALVANIZED (HG)
 - Zinc coated after all manufacturing operations are complete. Coating shall conform to ASTM A 123 or A 153.
- 5. SPECIAL COATING / MATERIAL
 - (Describe as applicable)

PART 3 - EXECUTION**3.01 EXAMINATION**

- A. The installer shall inspect the work area prior to installation. If work area conditions are unsatisfactory, installation shall not proceed until satisfactory corrections are completed.

3.02 INSTALLATION

- A. Installation shall be accomplished by a fully trained manufacturer authorized installer.
- B. Set Strut System components into final position true to line, level and plumb, in accordance with approved shop drawings.
- C. Anchor material firmly in place. Tighten all connections to their recommended torques.

3.03 CLEANUP

- A. Upon completion of this section of work, remove all protective wraps and debris. Repair any damage due to installation of this section of work.

3.04 PROTECTION

- A. During installation, it shall be the responsibility of the installer to protect this work from damage.
- B. Upon completion of this scope of work, it shall become the responsibility of the general contractor to protect this work from damage during the remainder of construction on the project and until substantial completion.



P1016

MISSING LINK MULTI-PURPOSE STRUT FASTENER

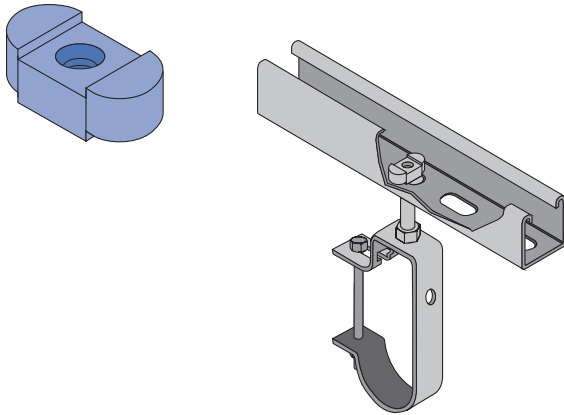

See Page 67

P2486

SEISMIC ROD STIFFENER

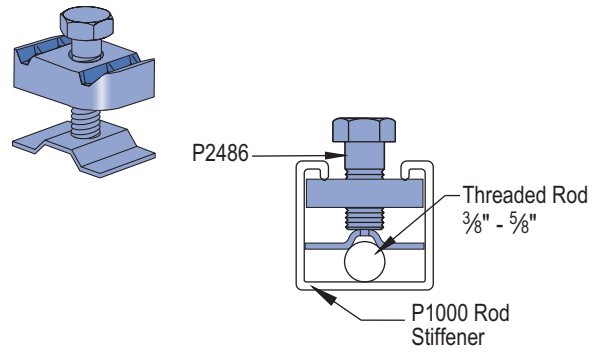

See Page 70

KWIK WASHER™

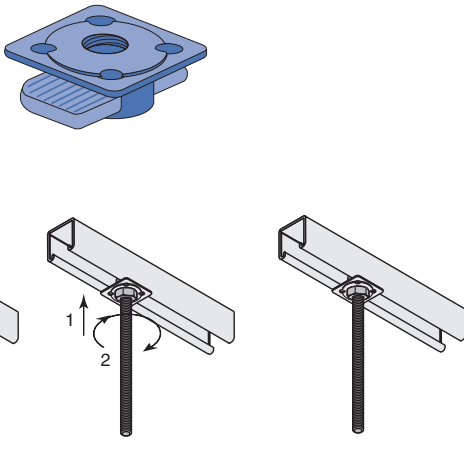

See Page 70

MUSTANG UNIVERSAL ONE-PIECE PIPE, CONDUIT AND TUBING CLAMP

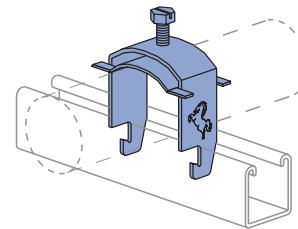

Size Range: 1/4" thru 4"

See Page 105



1⁵/₈" CHANNEL

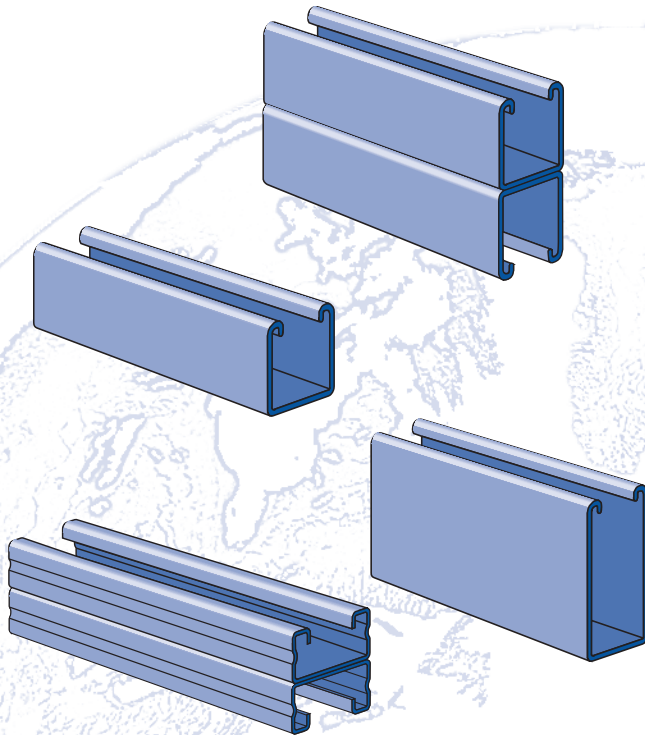

| | |
|---|-------|
| Channel Selection Chart | 22 |
| P1000 (12 Gauge) | 23 |
| P1100 (14 Gauge) | 24-29 |
| P2000 (16 Gauge) | 32 |
| P3000 (12 Gauge) | 33-35 |
| P3300 (12 Gauge) | 36-38 |
| P4000 (16 Gauge) | 42-44 |
| P4100 (14 Gauge) | 45-47 |
| P5000 (12 Gauge) | 48-50 |
| P5500 (12 Gauge) | 51-53 |
| Closure Strips | 54 |
| End Caps and Frame Caps | 55 |
| Lateral Bracing Load Reduction Chart & Bearing Loads..... | 56 |

MATERIAL

Unistrut channels are accurately and carefully cold formed to size from low-carbon strip steel.

All spot-welded combination members, except P1001T, are welded 3" (76 mm) maximum on center.

STEEL: PLAIN

12 Ga. (2.7 mm), 14 Ga. (1.9 mm) and 16 Ga. (1.5 mm) ASTM A1011 SS GR 33.

STEEL: PRE-GALVANIZED

12 Ga. (2.7 mm), 14 Ga. (1.9 mm) and 16 Ga. (1.5mm) ASTM A653 GR 33.

For other materials, see Special Metals or Fiberglass sections.

FINISHES

All channels are available in:

- Perma Green III (GR).
- Pre-galvanized (PG), conforming to ASTM A653 G90.
- Hot-dipped galvanized (HG), conforming to ASTM A123.
- Plain (PL).

DIMENSIONS

Imperial dimensions are illustrated in inches. Metric dimensions are shown in millimeters and rounded to one decimal place.

STANDARD LENGTHS

Standard lengths are 10 feet (3.05m) and 20 feet (6.10m). Tolerances are +¹/₈" (3 mm) to +¹/₂" (13 mm) to allow for cutting. Special lengths are available for a small cutting charge with a tolerance of ±¹/₈" (3 mm).

CURVED CHANNEL

Contact your local Unistrut Service Center or Unistrut Corporation for more information.

LOAD DATA

All beam and column load data pertains to carbon steel and stainless steel channels. Load tables and charts are constructed to be in accordance with the SPECIFICATION FOR THE DESIGN OF COLD-FORMED STEEL STRUCTURAL MEMBERS 2001 EDITION published by the AMERICAN IRON AND STEEL INSTITUTE USING ASD METHOD.

| Type of Load | Safety Factor to Yield Strength | Safety Factor to Ultimate Strength |
|--------------|---------------------------------|------------------------------------|
| Beam Loads | 1.67 | 2.0 |
| Column Load | 1.80 | 2.2 |



P1000 Series (12 ga.)

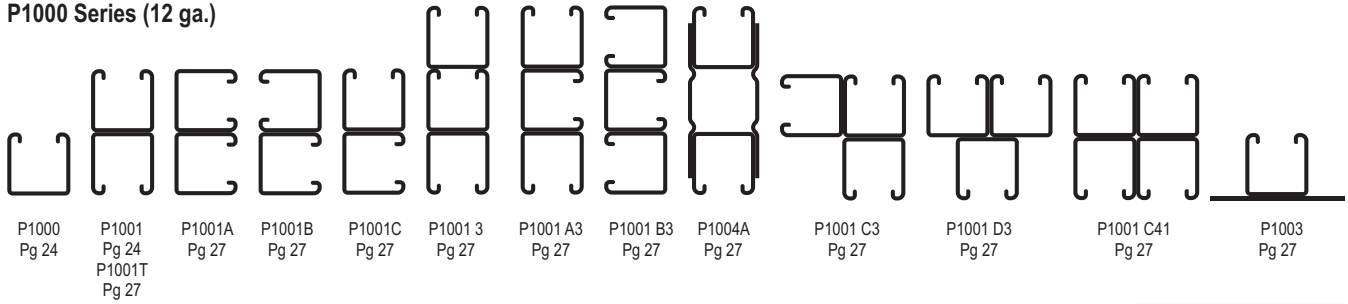

P1100 Series (14 ga.)

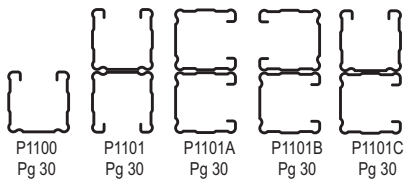

P2000 Series (16 ga.)

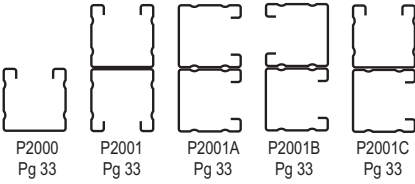

P3000 Series (12 ga.)

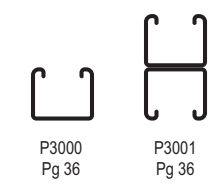

P3300 Series (12 ga.)

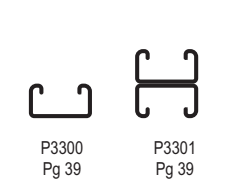

P4100 Series (14 ga.)

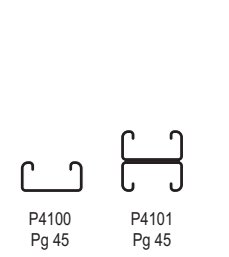

P4000 Series (16 ga.)

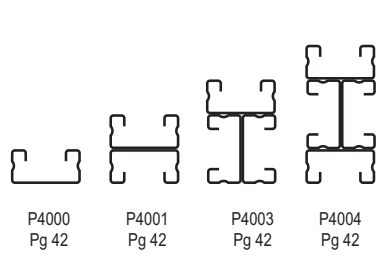

P5000 Series (12 ga.)

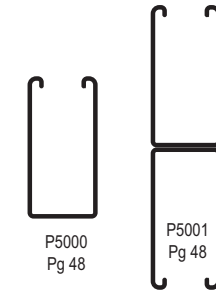

P5500 Series (12 ga.)

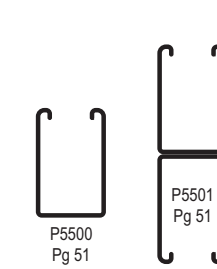

**P9000 Series (12 ga.)
Telestrut Channel**



End Caps and Frame Caps

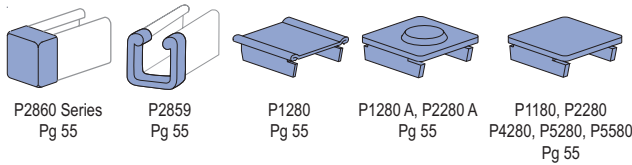

1 5/8" Channel Closure Strips

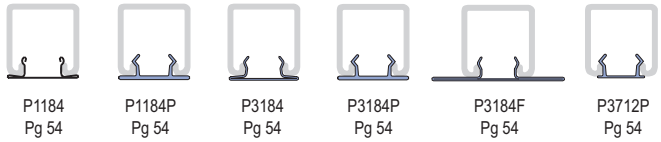

Alternate Framing Systems

A1000 Series (14 gauge) – 1 1/4" Channel

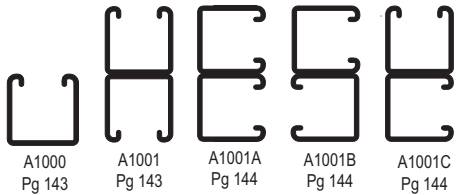

**A3300 Series (14 gauge)
1 1/4" Channel**

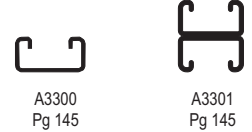

**A4000 Series (19 gauge)
1 1/4" Channel**

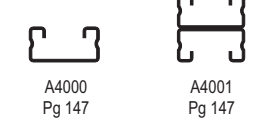

**A5000 Series (14 gauge)
1 1/4" Channel**

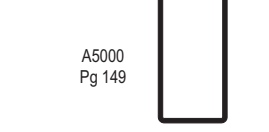

P6000 Series (19 gauge) – 1 3/16" Channel

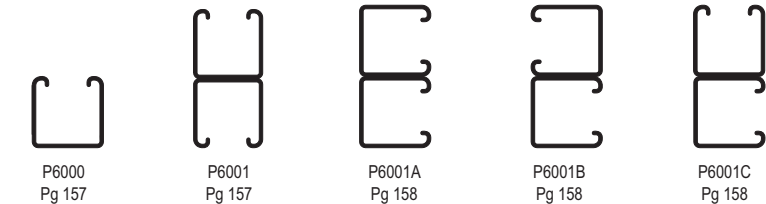

**P7000 Series (19 gauge)
1 3/16" Channel**

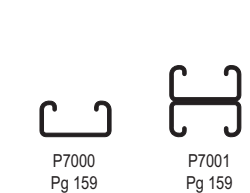

1 5/8" Channel
Telestrut System
Nuts & Hardware
General Fittings
Pipe/Conduit Supports
Electrical Fittings
Concrete Inserts
1 1/4" Framing System
1 3/16" Framing System
Special Metals
PrimeAngle System
Product Index

CHANNEL SELECTION CHART

| Channel | Channel Dimensions | | Material & Thickness | | | Hole Pattern Styles | | | | | |
|---------|--------------------|----------|----------------------|-----------------|-------------|---------------------|---|----|----|----|----|
| | | | Steel | Stainless Steel | Alum. | | | | | | |
| | Width | Height | | | | HS | T | KO | SL | DS | H3 |
| | In (mm) | In (mm) | gauge | gauge | In (mm) | Steel Only | | | | | |
| P1000 | 1½ (41) | 1½ (41) | 12 ga | 12 ga | 0.109 (2.8) | ■ | ■ | ■ | ■ | ■ | ■ |
| P1100 | 1½ (41) | 1½ (41) | 14 ga | 14 ga | — | ■ | ■ | ■ | ■ | — | — |
| P2000 | 1½ (41) | 1½ (41) | 16 ga | — | — | ■ | ■ | ■ | ■ | — | — |
| P3000 | 1½ (41) | 1¾ (35) | 12 ga | — | — | ■ | ■ | ■ | ■ | — | — |
| P3300 | 1½ (41) | 7⁄8 (22) | 12 ga | 12 ga | — | ■ | ■ | — | ■ | — | — |
| P4000 | 1½ (41) | 1⅜ (21) | 16 ga | 16 ga | 0.078 (2.0) | ■ | ■ | — | ■ | — | — |
| P4100 | 1½ (41) | 1⅜ (21) | 14 ga | — | — | ■ | ■ | — | ■ | — | — |
| P5000 | 1½ (41) | 3¼ (83) | 12 ga | 12 ga | — | ■ | ■ | ■ | ■ | — | — |
| P5500 | 1½ (41) | 2⅞ (62) | 12 ga | — | 0.109 (2.8) | ■ | ■ | ■ | ■ | — | — |

CHANNELS & COMBINATIONS IN DESCENDING ORDER OF STRENGTH

| Channel | Area In ² (cm ²) | Weight lbs/ft (kg/m) | I In ⁴ (cm ⁴) | s In ³ (cm ³) | Allow. Moment In-lbs (N*m) |
|----------|--|-------------------------|---|---|-------------------------------|
| P5001 | 1.793 11.57 | 6.10 9.1 | 6.227 259.2 | 1.916 31.4 | 48,180 5,440 |
| P1004A | 1.965 12.68 | 6.68 9.9 | 4.068 169.3 | 1.669 27.4 | 41,980 4,740 |
| P5501 | 1.452 9.37 | 4.94 7.3 | 2.805 116.8 | 1.151 18.9 | 28,940 3,270 |
| P1001C41 | 2.221 14.33 | 7.55 11.2 | 1.856 77.2 | 1.142 18.7 | 28,720 3,250 |
| P5000 | 0.897 5.78 | 3.05 4.5 | 1.098 45.7 | 0.627 10.3 | 15,770 1,780 |
| P1001 | 1.111 7.16 | 3.78 5.6 | 0.928 38.6 | 0.571 9.4 | 14,360 1,620 |
| P1101 | 0.835 5.39 | 2.84 4.2 | 0.733 30.5 | 0.451 7.4 | 11,340 1,280 |
| P3001 | 1.000 6.45 | 3.40 5.1 | 0.591 24.6 | 0.430 7.0 | 10,810 1,220 |
| P5500 | 0.726 4.68 | 2.47 3.7 | 0.522 21.7 | 0.390 6.4 | 9,820 1,110 |
| P2001 | 0.684 4.41 | 2.32 3.5 | 0.618 25.7 | 0.381 6.2 | 9,570 1,080 |
| P9200 | 0.489 3.16 | 2.23 3.3 | 0.279 11.6 | 0.297 4.9 | 7,480 850 |
| A5000 | 0.492 3.17 | 1.67 2.5 | 0.358 14.9 | 0.265 4.3 | 6,670 750 |
| A1001 | 0.609 3.93 | 2.07 3.1 | 0.302 12.6 | 0.242 4.0 | 6,070 690 |
| P9000 | 0.387 2.50 | 1.88 2.8 | 0.166 6.9 | 0.205 3.4 | 5,150 580 |
| P1000 | 0.555 3.58 | 1.89 2.8 | 0.185 7.7 | 0.202 3.3 | 5,070 570 |
| P3301 | 0.790 5.10 | 2.69 4.0 | 0.176 7.3 | 0.201 3.3 | 5,060 570 |

Combinations not shown in catalog are available on special order. Consult factory for more details.

| Channel | Area In ² (cm ²) | Weight lbs/ft (kg/m) | I In ⁴ (cm ⁴) | s In ³ (cm ³) | Allow. Moment In-lbs (N*m) |
|---------|--|-------------------------|---|---|-------------------------------|
| P1100 | 0.418 2.69 | 1.42 2.1 | 0.145 6.0 | 0.162 2.6 | 4,060 460 |
| P3000 | 0.500 3.23 | 1.70 2.5 | 0.120 5.0 | 0.153 2.5 | 3,850 430 |
| P4101 | 0.579 3.74 | 1.97 2.9 | 0.117 4.9 | 0.143 2.4 | 3,610 410 |
| P2000 | 0.342 2.21 | 1.16 1.7 | 0.125 5.2 | 0.140 2.3 | 3,520 400 |
| P4001 | 0.478 3.14 | 1.66 2.5 | 0.104 4.3 | 0.128 2.1 | 3,210 360 |
| A3301 | 0.459 2.96 | 1.56 2.3 | 0.077 3.2 | 0.103 1.7 | 2,590 290 |
| A1000 | 0.305 1.96 | 1.04 1.5 | 0.061 2.5 | 0.086 1.4 | 2,170 250 |
| P3300 | 0.395 2.55 | 1.34 2.0 | 0.037 1.5 | 0.072 1.2 | 1,800 200 |
| A4001 | 0.264 1.70 | 0.90 1.3 | 0.037 1.5 | 0.058 1.0 | 1,470 170 |
| P6001 | 0.213 1.38 | 0.73 1.1 | 0.045 1.9 | 0.055 0.9 | 1,400 160 |
| P4100 | 0.290 1.87 | 0.98 1.5 | 0.026 1.1 | 0.054 0.9 | 1,360 150 |
| P4000 | 0.244 1.57 | 0.83 1.2 | 0.023 0.9 | 0.049 0.8 | 1,230 140 |
| A3300 | 0.230 1.48 | 0.78 1.2 | 0.017 0.7 | 0.038 0.6 | 950 110 |
| A4000 | 0.132 0.85 | 0.45 0.7 | 0.008 0.3 | 0.022 0.4 | 560 60 |
| P6000 | 0.107 0.69 | 0.36 0.5 | 0.009 0.4 | 0.020 0.3 | 510 60 |
| P7001 | 0.148 0.96 | 0.50 0.8 | 0.007 0.3 | 0.018 0.3 | 460 50 |
| P7000 | 0.074 0.48 | 0.25 0.4 | 0.002 0.1 | 0.007 0.1 | 170 20 |



P1000®

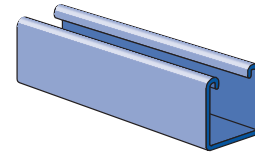
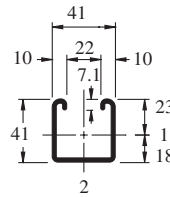
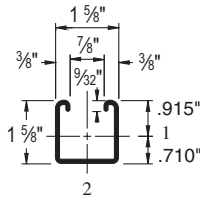

Wt/100 Ft: 189 Lbs (281 kg/100 m)
 Allowable Moment 5,070 In-Lbs (570 N•m)
 12 Gauge Nominal Thickness .105" (2.7mm)

P1001

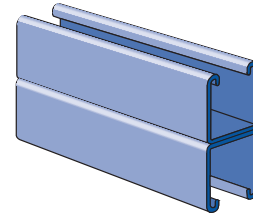
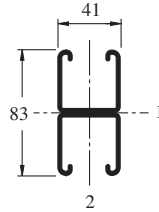
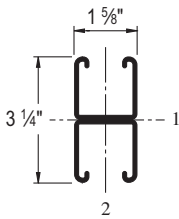

Wt/100 Ft: 378 Lbs (562 kg/100 m)
 Allowable Moment 14,360 In-Lbs (1,620 N•m)
 12 Gauge Nominal Thickness .105" (2.7mm)

P1000 DS

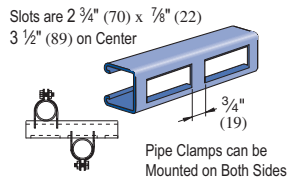

Wt/100 Ft: 173 Lbs (257 kg/100 m)

P1000 H3

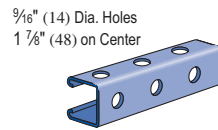

Wt/100 Ft: 175 Lbs (260 kg/100 m)

P1000 HS

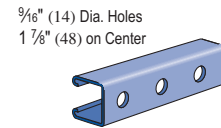

Wt/100 Ft: 185 Lbs (275 kg/100 m)

P1000 KO

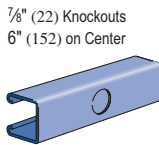

Wt/100 Ft: 190 Lbs (283 kg/100 m)

P1000 SL

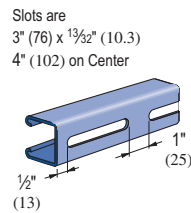

Wt/100 Ft: 185 Lbs (275 kg/100 m)

P1000 T

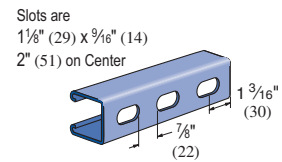

Wt/100 Ft: 185 Lbs (275 kg/100 m)

CHANNEL NUTS (REFER TO HARDWARE SECTION FOR DETAILS)

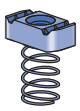

P1006-0832
P1006-1024
P1006-1420
P1007
P1008
P1009
P1010



P1008T
P1006T1420
P1010T



P1024
P1012S
P1023S



P1012
P1023
P1024S



P3006-0832
P3006-1024
P3006-1420
P3007
P3008
P3009
P3010



P3016-0632
P3016-0832
P3016-1024
P3016-1420

Channel Finishes: PL, GR, HG, PG; Standard Lengths: 10' & 20'

1 5/8" Channel
 Telestrut System
 Nuts & Hardware
 General Fittings
 Pipe/Conduit Supports
 Electrical Fittings
 Concrete Inserts
 1 1/4" Framing System
 1 3/4" Framing System
 Fiberglass System
 Special Metals
 PrimeAngle System
 Product Index

P1000 - BEAM LOADING

| Span In | Max. Allowable Uniform Load Lbs | Defl. at Uniform Load In | Uniform Loading at Deflection | | |
|---------|---------------------------------|--------------------------|-------------------------------|--------------|--------------|
| | | | Span/180 Lbs | Span/240 Lbs | Span/360 Lbs |
| 24 | 1,690 | 0.06 | 1,690 | 1,690 | 1,690 |
| 36 | 1,130 | 0.13 | 1,130 | 1,130 | 900 |
| 48 | 850 | 0.22 | 850 | 760 | 500 |
| 60 | 680 | 0.35 | 650 | 480 | 320 |
| 72 | 560 | 0.50 | 450 | 340 | 220 |
| 84 | 480 | 0.68 | 330 | 250 | 160 |
| 96 | 420 | 0.89 | 250 | 190 | 130 |
| 108 | 380 | 1.14 | 200 | 150 | 100 |
| 120 | 340 | 1.40 | 160 | 120 | 80 |
| 144 | 280 | 2.00 | 110 | 80 | 60 |
| 168 | 240 | 2.72 | 80 | 60 | 40 |
| 192 | 210 | 3.55 | 60 | 50 | NR |
| 216 | 190 | 4.58 | 50 | 40 | NR |
| 240 | 170 | 5.62 | 40 | NR | NR |

P1001 - BEAM LOADING

| Span In | Max. Allowable Uniform Load Lbs | Defl. at Uniform Load In | Uniform Loading at Deflection | | |
|---------|---------------------------------|--------------------------|-------------------------------|--------------|--------------|
| | | | Span/180 Lbs | Span/240 Lbs | Span/360 Lbs |
| 24 | 3,500* | 0.02 | 3,500* | 3,500* | 3,500* |
| 36 | 3,190 | 0.07 | 3,190 | 3,190 | 3,190 |
| 48 | 2,390 | 0.13 | 2,390 | 2,390 | 2,390 |
| 60 | 1,910 | 0.20 | 1,910 | 1,910 | 1,620 |
| 72 | 1,600 | 0.28 | 1,600 | 1,600 | 1,130 |
| 84 | 1,370 | 0.39 | 1,370 | 1,240 | 830 |
| 96 | 1,200 | 0.51 | 1,200 | 950 | 630 |
| 108 | 1,060 | 0.64 | 1,000 | 750 | 500 |
| 120 | 960 | 0.79 | 810 | 610 | 410 |
| 144 | 800 | 1.14 | 560 | 420 | 280 |
| 168 | 680 | 1.53 | 410 | 310 | 210 |
| 192 | 600 | 2.02 | 320 | 240 | 160 |
| 216 | 530 | 2.54 | 250 | 190 | 130 |
| 240 | 480 | 3.16 | 200 | 150 | 100 |

P1000 - COLUMN LOADING

| Unbraced Height In | Max. Allowable Load at Slot Face Lbs | Maximum Column Load Applied at C.G. | | | |
|--------------------|--------------------------------------|-------------------------------------|--------------|-------------|-------------|
| | | K = 0.65 Lbs | K = 0.80 Lbs | K = 1.0 Lbs | K = 1.2 Lbs |
| 24 | 3,550 | 10,740 | 9,890 | 8,770 | 7,740 |
| 36 | 3,190 | 8,910 | 7,740 | 6,390 | 5,310 |
| 48 | 2,770 | 7,260 | 6,010 | 4,690 | 3,800 |
| 60 | 2,380 | 5,910 | 4,690 | 3,630 | 2,960 |
| 72 | 2,080 | 4,840 | 3,800 | 2,960 | 2,400 |
| 84 | 1,860 | 4,040 | 3,200 | 2,480 | 1,980 |
| 96 | 1,670 | 3,480 | 2,750 | 2,110 | 1,660 |
| 108 | 1,510 | 3,050 | 2,400 | 1,810 | ** |
| 120 | 1,380 | 2,700 | 2,110 | ** | ** |
| 144 | 1,150 | 2,180 | 1,660 | ** | ** |

P1001 - COLUMN LOADING

| Unbraced Height In | Max. Allowable Load at Slot Face Lbs | Maximum Column Load Applied at C.G. | | | |
|--------------------|--------------------------------------|-------------------------------------|--------------|-------------|-------------|
| | | K = 0.65 Lbs | K = 0.80 Lbs | K = 1.0 Lbs | K = 1.2 Lbs |
| 24 | 6,430 | 24,280 | 23,610 | 22,700 | 21,820 |
| 36 | 6,290 | 22,810 | 21,820 | 20,650 | 19,670 |
| 48 | 6,160 | 21,410 | 20,300 | 18,670 | 16,160 |
| 60 | 6,000 | 20,210 | 18,670 | 15,520 | 12,390 |
| 72 | 5,620 | 18,970 | 16,160 | 12,390 | 8,950 |
| 84 | 5,170 | 16,950 | 13,630 | 9,470 | 6,580 |
| 96 | 4,690 | 14,890 | 11,190 | 7,250 | 5,040 |
| 108 | 4,170 | 12,850 | 8,950 | 5,730 | 3,980 |
| 120 | 3,690 | 10,900 | 7,250 | 4,640 | ** |
| 144 | 2,930 | 7,630 | 5,040 | ** | ** |

P1000/P1001 - ELEMENTS OF SECTION

| Parameter | P1000 | P1001 |
|------------------------|-----------------------|-----------------------|
| Area of Section | 0.555 In ² | 1.111 In ² |
| Axis 1-1 | | |
| Moment of Inertia (I) | 0.185 In ⁴ | 0.928 In ⁴ |
| Section Modulus (S) | 0.202 In ³ | 0.571 In ³ |
| Radius of Gyration (r) | 0.577 In | 0.914 In |
| Axis 2-2 | | |
| Moment of Inertia (I) | 0.236 In ⁴ | 0.471 In ⁴ |
| Section Modulus (S) | 0.290 In ³ | 0.580 In ³ |
| Radius of Gyration (r) | 0.651 In | 0.651 In |

Notes:

* Load limited by spot weld shear.

** KL/r > 200

NR = Not Recommended.

- Above loads include the weight of the member. This weight must be deducted to arrive at the net allowable load the beam will support.
- Long span beams should be supported in such a manner as to prevent rotation and twist.
- Allowable uniformly distributed loads are listed for various simple spans, that is, a beam on two supports. If load is concentrated at the center of the span, multiply load from the table by 0.5 and corresponding deflection by 0.8.
- See page 56 for lateral bracing reduction charts.
- For Pierced Channel, Beam Load Values in the tables are multiplied by the following factor:

| | | | |
|-------------|-----|-------------|-----|
| "DS" Series | 70% | "T" Series | 85% |
| "KO" Series | 95% | "H3" Series | 90% |
| "SL" Series | 85% | "HS" Series | 90% |



P1000 - BEAM LOADING (METRIC)

| Span mm | Max Allowable Uniform Load kN | Defl. at Uniform Load mm | Uniform Loading at Deflection | | |
|------------|--|-----------------------------------|-------------------------------|----------------|----------------|
| | | | Span/180 kN | Span/240 kN | Span/360 kN |
| 600 | 7.6 | 1 | 7.6 | 7.6 | 7.6 |
| 750 | 6.1 | 2 | 6.1 | 6.1 | 5.9 |
| 1,000 | 4.6 | 4 | 4.6 | 4.6 | 3.3 |
| 1,250 | 3.6 | 6 | 3.6 | 3.2 | 2.1 |
| 1,500 | 3.1 | 9 | 3.0 | 2.2 | 1.5 |
| 1,750 | 2.6 | 12 | 2.2 | 1.6 | 1.1 |
| 2,000 | 2.3 | 15 | 1.6 | 1.2 | 0.8 |
| 2,500 | 1.8 | 24 | 1.1 | 0.8 | 0.5 |
| 3,000 | 1.5 | 34 | 0.8 | 0.5 | 0.4 |
| 3,500 | 1.3 | 46 | 0.5 | 0.4 | 0.3 |
| 4,000 | 1.2 | 62 | 0.4 | 0.3 | 0.2 |
| 4,500 | 1.0 | 78 | 0.3 | 0.3 | 0.2 |
| 5,000 | 0.9 | 97 | 0.3 | 0.2 | NR |
| 6,000 | 0.8 | 136 | 0.2 | NR | NR |

P1001 - BEAM LOADING (METRIC)

| Span mm | Max Allowable Uniform Load kN | Defl. at Uniform Load mm | Uniform Loading at Deflection | | |
|------------|--|-----------------------------------|-------------------------------|----------------|----------------|
| | | | Span/180 kN | Span/240 kN | Span/360 kN |
| 600 | 15.6 * | 1 | 15.6 * | 15.6 * | 15.6 * |
| 750 | 15.6 * | 1 | 15.6 * | 15.6 * | 15.6 * |
| 1,000 | 13.0 | 2 | 13.0 | 13.0 | 13.0 |
| 1,250 | 10.4 | 3 | 10.4 | 10.4 | 10.4 |
| 1,500 | 8.7 | 5 | 8.7 | 8.7 | 7.4 |
| 1,750 | 7.4 | 7 | 7.4 | 7.4 | 5.5 |
| 2,000 | 6.5 | 9 | 6.5 | 6.3 | 4.2 |
| 2,500 | 5.2 | 13 | 5.2 | 4.0 | 2.7 |
| 3,000 | 4.3 | 19 | 3.7 | 2.8 | 1.9 |
| 3,500 | 3.7 | 26 | 2.8 | 2.0 | 1.4 |
| 4,000 | 3.2 | 34 | 2.1 | 1.6 | 1.1 |
| 4,500 | 2.9 | 44 | 1.6 | 1.2 | 0.8 |
| 5,000 | 2.6 | 53 | 1.3 | 1.0 | 0.7 |
| 6,000 | 2.2 | 78 | 0.9 | 0.7 | 0.4 |

P1000 - COLUMN LOADING (METRIC)

| Unbraced Height mm | Maximum Allowable Load at Slot Face kN | Maximum Column Load Applied at C.G. | | | |
|--------------------------|---|-------------------------------------|----------------|---------------|---------------|
| | | K = 0.65 kN | K = 0.80 kN | K = 1.0 kN | K = 1.2 kN |
| 600 | 15.8 | 48.0 | 44.3 | 39.4 | 34.8 |
| 750 | 15.2 | 44.0 | 39.4 | 33.8 | 28.9 |
| 1,000 | 13.7 | 37.5 | 32.0 | 26.1 | 21.3 |
| 1,250 | 12.1 | 31.6 | 26.1 | 20.3 | 16.5 |
| 1,500 | 10.7 | 26.7 | 21.3 | 16.5 | 13.4 |
| 1,750 | 9.6 | 22.7 | 17.8 | 13.8 | 11.3 |
| 2,000 | 8.7 | 19.3 | 15.3 | 11.9 | 9.6 |
| 2,250 | 7.9 | 16.9 | 13.4 | 10.4 | 8.2 |
| 2,500 | 7.2 | 15.0 | 11.9 | 9.1 | ** |
| 2,750 | 6.7 | 13.5 | 10.6 | 8.1 | ** |

P1001 - COLUMN LOADING (METRIC)

| Unbraced Height mm | Maximum Allowable Load at Slot Face kN | Maximum Column Load Applied at C.G. | | | |
|--------------------------|---|-------------------------------------|----------------|---------------|---------------|
| | | K = 0.65 kN | K = 0.80 kN | K = 1.0 kN | K = 1.2 kN |
| 600 | 28.6 | 108.2 | 105.3 | 101.3 | 97.4 |
| 750 | 28.3 | 105.0 | 101.3 | 96.5 | 92.2 |
| 1,000 | 27.8 | 99.6 | 95.0 | 89.7 | 83.9 |
| 1,250 | 27.3 | 94.7 | 89.7 | 81.7 | 70.1 |
| 1,500 | 26.8 | 90.3 | 83.9 | 70.1 | 56.4 |
| 1,750 | 25.4 | 86.7 | 74.8 | 58.6 | 43.5 |
| 2,000 | 23.9 | 79.4 | 65.5 | 47.7 | 33.3 |
| 2,250 | 22.2 | 71.9 | 56.4 | 37.9 | 26.3 |
| 2,500 | 20.4 | 64.4 | 47.7 | 30.7 | 21.3 |
| 2,750 | 18.5 | 56.9 | 39.6 | 25.4 | 17.6 |

P1000/P1001 - ELEMENTS OF SECTION (METRIC)

| Parameter | P1000 | P1001 |
|------------------------|----------------------|-----------------------|
| Area of Section | 3.58 cm ² | 7.16 cm ² |
| Axis 1-1 | | |
| Moment of Inertia (I) | 7.68 cm ⁴ | 38.62 cm ⁴ |
| Section Modulus (S) | 3.30 cm ³ | 9.36 cm ³ |
| Radius of Gyration (r) | 1.46 cm | 2.32 cm |
| Axis 2-2 | | |
| Moment of Inertia (I) | 9.80 cm ⁴ | 19.60 cm ⁴ |
| Section Modulus (S) | 4.75 cm ³ | 9.50 cm ³ |
| Radius of Gyration (r) | 1.65 cm | 1.65 cm |

Notes:

* Load limited by spot weld shear.

** KL/r > 200

NR = Not Recommended.

- Above loads include the weight of the member. This weight must be deducted to arrive at the net allowable load the beam will support.
- Long span beams should be supported in such a manner as to prevent rotation and twist.
- Allowable uniformly distributed loads are listed for various simple spans, that is, a beam on two supports. If load is concentrated at the center of the span, multiply load from the table by 0.5 and corresponding deflection by 0.8.
- See page 56 for lateral bracing reduction charts.
- For Pierced Channel, Beam Load Values in the tables are multiplied by the following factor:

| | | | |
|-------------|-----|-------------|-----|
| "DS" Series | 70% | "T" Series | 85% |
| "KO" Series | 95% | "H3" Series | 90% |
| "SL" Series | 85% | "HS" Series | 90% |

1 5/8" Channel
 Telesnut System
 Nuts & Hardware
 General Fittings
 Pipe/Conduit Supports
 Electrical Fittings
 Concrete Inserts
 1 1/4" Framing System
 1 3/8" Framing System
 Fiberglass System
 Special Metals
 PrimeAngle System
 Product Index

P1001 T

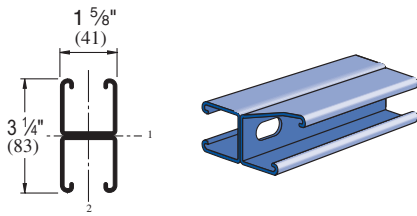

Wt/100 Ft: 321 Lbs (478 kg/100 m)
 Allowable Moment 12,200 In-Lbs (1,378 N•m)
 12 Gauge Nominal Thickness .105" (2.7mm)

P1001 A

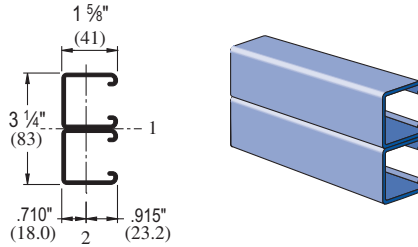

Wt/100 Ft: 378 Lbs (562 kg/100 m)
 Allowable Moment 18,640 In-Lbs (2,110 N•m)
 12 Gauge Nominal Thickness .105" (2.7mm)

P1001 B

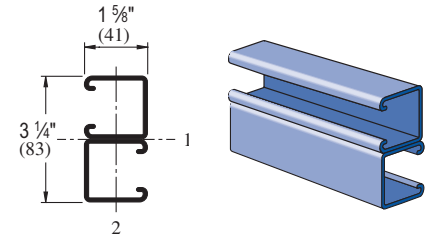

Wt/100 Ft: 378 Lbs (562 kg/100 m)
 Allowable Moment 18,640 In-Lbs (2,110 N•m)
 12 Gauge Nominal Thickness .105" (2.7mm)

P1001 C

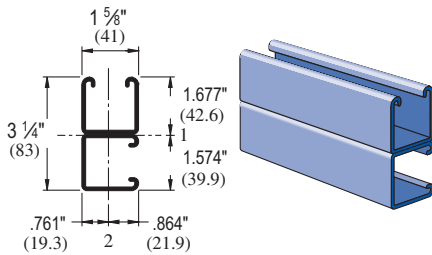

Wt/100 Ft: 378 Lbs (562 kg/100 m)
 Allowable Moment 15,950 In-Lbs (1,800 N•m)
 12 Gauge Nominal Thickness .105" (2.7mm)

P1001 3

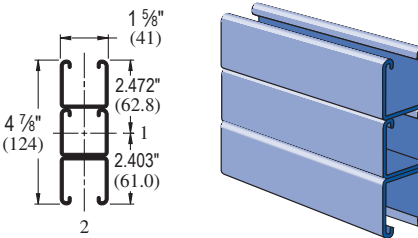

Wt/100 Ft: 566 Lbs (843 kg/100 m)
 Allowable Moment 31,840 In-Lbs (3,600 N•m)
 12 Gauge Nominal Thickness .105" (2.7mm)

P1001 A3

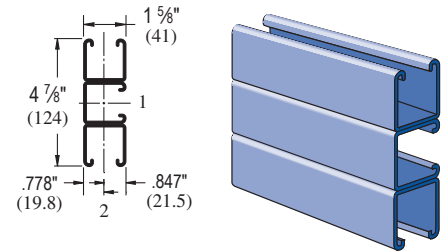

Wt/100 Ft: 566 Lbs (843 kg/100 m)
 Allowable Moment 32,770 In-Lbs (3,700 N•m)
 12 Gauge Nominal Thickness .105" (2.7mm)

P1001 B3

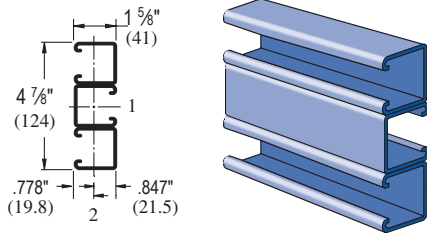

Wt/100 Ft: 566 Lbs (843 kg/100 m)
 Allowable Moment 37,550 In-Lbs (4,240 N•m)
 12 Gauge Nominal Thickness .105" (2.7mm)

P1001 D3

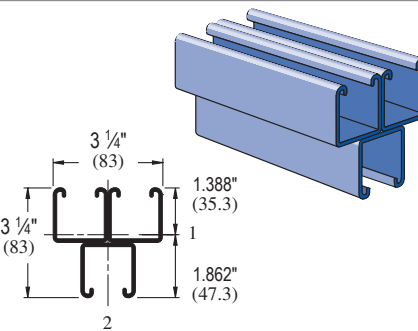

Wt/100 Ft: 566 Lbs (843 kg/100 m)
 Allowable Moment 17,550 In-Lbs (1,980 N•m)
 12 Gauge Nominal Thickness .105" (2.7mm)

P1003

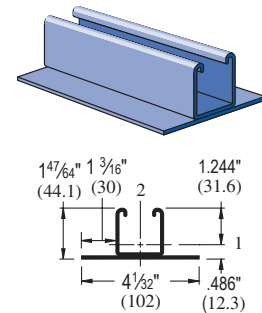

Wt/100 Ft: 333 Lbs (495 kg/100 m)
 Allowable Moment 6,240 In-Lbs (700 N•m)
 12 Gauge Nominal Thickness .105" (2.7mm)

P1001 C41

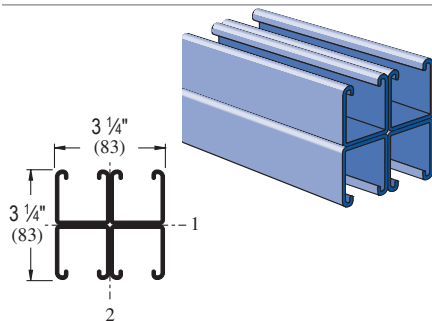

Wt/100 Ft: 755 Lbs (1,124 kg/100 m)
 Allowable Moment 28,720 In-Lbs (3,250 N•m)
 12 Gauge Nominal Thickness .105" (2.7mm)

P1001 C3

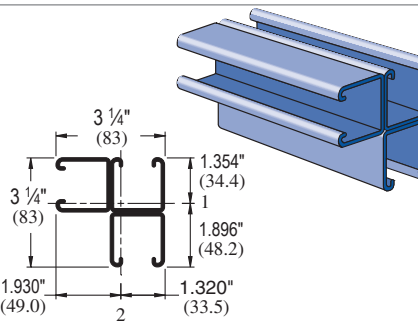

Wt/100 Ft: 566 Lbs (843 kg/100 m)
 Allowable Moment 18,680 In-Lbs (2,110 N•m)
 12 Gauge Nominal Thickness .105" (2.7mm)

P1004 A

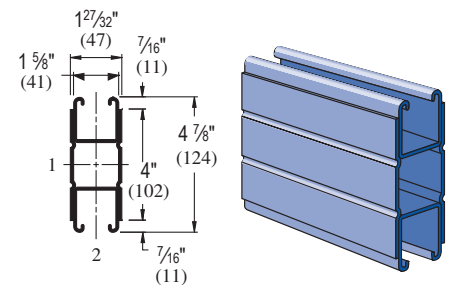

Wt/100 Ft: 668 Lbs (994 kg/100 m)
 Allowable Moment 41,970 In-Lbs (4,740 N•m)
 12 Gauge Nominal Thickness .105" (2.7mm)

Channel Finishes: PL, GR, HG, PG; Standard Lengths: 10' & 20'



P1001 C41 - BEAM LOADING

| Span In | Max Allowable Uniform Load Lbs | Defl. at Uniform Load In | Uniform Loading at Deflection | | |
|---------|--------------------------------|--------------------------|-------------------------------|--------------|--------------|
| | | | Span/180 Lbs | Span/240 Lbs | Span/360 Lbs |
| 24 | 7,040* | 0.02 | 7,040* | 7,040* | 7,040* |
| 36 | 6,380 | 0.07 | 6,380 | 6,380 | 6,380 |
| 48 | 4,790 | 0.13 | 4,790 | 4,790 | 4,790 |
| 60 | 3,830 | 0.20 | 3,830 | 3,830 | 3,240 |
| 72 | 3,190 | 0.28 | 3,190 | 3,190 | 2,250 |
| 84 | 2,740 | 0.39 | 2,740 | 2,480 | 1,660 |
| 96 | 2,390 | 0.50 | 2,390 | 1,900 | 1,270 |
| 108 | 2,130 | 0.64 | 2,000 | 1,500 | 1,000 |
| 120 | 1,910 | 0.78 | 1,620 | 1,220 | 810 |
| 144 | 1,600 | 1.14 | 1,130 | 840 | 560 |
| 168 | 1,370 | 1.55 | 830 | 620 | 410 |
| 192 | 1,200 | 2.02 | 630 | 480 | 320 |
| 216 | 1,060 | 2.54 | 500 | 380 | 250 |
| 240 | 960 | 3.16 | 410 | 300 | 200 |

P1004 A - BEAM LOADING

| Span In | Max Allowable Uniform Load Lbs | Defl. at Uniform Load In | Uniform Loading at Deflection | | |
|---------|--------------------------------|--------------------------|-------------------------------|--------------|--------------|
| | | | Span/180 Lbs | Span/240 Lbs | Span/360 Lbs |
| 24 | 9,100* | 0.01 | 9,100* | 9,100* | 9,100* |
| 36 | 9,100* | 0.05 | 9,100* | 9,100* | 9,100* |
| 48 | 7,000 | 0.08 | 7,000 | 7,000 | 7,000 |
| 60 | 5,600 | 0.13 | 5,600 | 5,600 | 5,600 |
| 72 | 4,660 | 0.19 | 4,660 | 4,660 | 4,660 |
| 84 | 4,000 | 0.26 | 4,000 | 4,000 | 3,630 |
| 96 | 3,500 | 0.34 | 3,500 | 3,500 | 2,780 |
| 108 | 3,110 | 0.43 | 3,110 | 3,110 | 2,200 |
| 120 | 2,800 | 0.52 | 2,800 | 2,670 | 1,780 |
| 144 | 2,330 | 0.75 | 2,330 | 1,850 | 1,230 |
| 168 | 2,000 | 1.03 | 1,810 | 1,360 | 910 |
| 192 | 1,750 | 1.34 | 1,390 | 1,040 | 690 |
| 216 | 1,550 | 1.69 | 1,100 | 820 | 550 |
| 240 | 1,400 | 2.10 | 890 | 670 | 440 |

P1001 C41 - COLUMN LOADING

| Unbraced Height In | Maximum Allowable Load at Slot Face Lbs | Maximum Column Load Applied at C.G. | | | |
|--------------------|---|-------------------------------------|--------------|-------------|-------------|
| | | K = 0.65 Lbs | K = 0.80 Lbs | K = 1.0 Lbs | K = 1.2 Lbs |
| 24 | 12,690 | 46,920 | 44,980 | 42,360 | 39,890 |
| 36 | 12,250 | 42,680 | 39,890 | 36,660 | 34,050 |
| 48 | 11,820 | 38,740 | 35,720 | 32,640 | 30,430 |
| 60 | 11,470 | 35,500 | 32,640 | 29,980 | 28,220 |
| 72 | 11,180 | 32,970 | 30,430 | 28,220 | 26,820 |
| 84 | 10,900 | 31,040 | 28,840 | 27,010 | 24,870 |
| 96 | 10,580 | 29,570 | 27,680 | 26,170 | 19,840 |
| 108 | 10,310 | 28,440 | 26,820 | 22,310 | 15,670 |
| 120 | 10,070 | 27,560 | 26,170 | 18,280 | 12,700 |
| 144 | 8,740 | 26,320 | 19,840 | 12,700 | 8,820 |
| 168 | 7,360 | 21,890 | 14,570 | 9,330 | ** |

P1004 A - COLUMN LOADING

| Unbraced Height In | Maximum Allowable Load at Slot Face Lbs | Maximum Column Load Applied at C.G. | | | |
|--------------------|---|-------------------------------------|--------------|-------------|-------------|
| | | K = 0.65 Lbs | K = 0.80 Lbs | K = 1.0 Lbs | K = 1.2 Lbs |
| 24 | 11,420 | 36,800 | 33,890 | 30,440 | 27,600 |
| 36 | 10,600 | 30,840 | 27,600 | 24,400 | 22,160 |
| 48 | 9,860 | 26,400 | 23,560 | 21,060 | 19,470 |
| 60 | 9,160 | 23,370 | 21,060 | 19,160 | 18,020 |
| 72 | 8,610 | 21,310 | 19,470 | 18,020 | 17,140 |
| 84 | 8,170 | 19,890 | 18,410 | 17,260 | 15,240 |
| 96 | 7,790 | 18,890 | 17,670 | 16,760 | 11,670 |
| 108 | 7,460 | 18,160 | 17,140 | 13,280 | 9,220 |
| 120 | 7,150 | 17,590 | 16,760 | 10,750 | 7,470 |
| 144 | 5,660 | 16,840 | 11,670 | 7,470 | ** |
| 168 | 4,520 | 12,990 | 8,570 | ** | ** |

P1001 C41/ P1004 A - ELEMENTS OF SECTION

| Parameter | P1001 C41 | P1004 A |
|------------------------|-----------------------|-----------------------|
| Area of Section | 2.221 in ² | 1.965 in ² |
| Axis 1-1 | | |
| Moment of Inertia (I) | 1.856 in ⁴ | 4.068 in ⁴ |
| Section Modulus (S) | 1.142 in ³ | 1.669 in ³ |
| Radius of Gyration (r) | 0.914 in | 1.439 in |
| Axis 2-2 | | |
| Moment of Inertia (I) | 2.408 in ⁴ | 1.092 in ⁴ |
| Section Modulus (S) | 1.482 in ³ | 1.190 in ³ |
| Radius of Gyration (r) | 1.041 in | 0.745 in |

*Load limited by spot weld shear.

** $K L / r > 200$

Notes:

- Above loads include the weight of the member. This weight must be deducted to arrive at the net allowable load the beam will support.
- Long span beams should be supported in such a manner as to prevent rotation and twist.
- Allowable uniformly distributed loads are listed for various simple spans, that is, a beam on two supports. If load is concentrated at the center of the span, multiply load from the table by 0.5 and corresponding deflection by 0.8.
- See page 56 for lateral bracing reduction charts.

1 5/8" Channel
 Telestrut System
 Nuts & Hardware
 General Fittings
 Pipe/Conduit Supports
 Electrical Fittings
 Concrete Inserts
 1 1/4" Framing System
 1 3/16" Framing System
 Fiberglass System
 Special Metals
 PrimeAngle System
 Product Index

P1001 C41 - BEAM LOADING (METRIC)

| Span mm | Max Allowable Uniform Load kN | Defl. at Uniform Load mm | Uniform Loading at Deflection | | |
|------------|--|-----------------------------------|-------------------------------|----------------|----------------|
| | | | Span/180 kN | Span/240 kN | Span/360 kN |
| 600 | 31.3 * | 1 | 31.3 * | 31.3 * | 31.3 * |
| 750 | 31.3 * | 1 | 31.3 * | 31.3 * | 31.3 * |
| 1,000 | 26.0 | 2 | 26.0 | 26.0 | 26.0 |
| 1,250 | 20.8 | 3 | 20.8 | 20.8 | 20.8 |
| 1,500 | 17.3 | 5 | 17.3 | 17.3 | 14.9 |
| 1,750 | 14.8 | 7 | 14.8 | 14.8 | 10.9 |
| 2,000 | 13.0 | 9 | 13.0 | 12.6 | 8.4 |
| 2,500 | 10.4 | 13 | 10.4 | 8.1 | 5.4 |
| 3,000 | 8.7 | 19 | 7.4 | 5.6 | 3.7 |
| 3,500 | 7.4 | 26 | 5.5 | 4.1 | 2.8 |
| 4,000 | 6.5 | 34 | 4.2 | 3.2 | 2.1 |
| 4,500 | 5.8 | 44 | 3.3 | 2.5 | 1.6 |
| 5,000 | 5.2 | 54 | 2.7 | 2.0 | 1.3 |
| 6,000 | 4.3 | 77 | 1.9 | 1.4 | 0.9 |

P1004 A - BEAM LOADING (METRIC)

| Span mm | Max Allowable Uniform Load kN | Defl. at Uniform Load mm | Uniform Loading at Deflection | | |
|------------|--|-----------------------------------|-------------------------------|-----------------|----------------|
| | | | Span/180 kN | Span/240 kgN | Span/360 kN |
| 600 | 40.5 * | 1 | 40.5 * | 40.5 * | 40.5 * |
| 750 | 40.5 * | 1 | 40.5 * | 40.5 * | 40.5 * |
| 1,000 | 37.9 | 2 | 37.9 | 37.9 | 37.9 |
| 1,250 | 30.3 | 3 | 30.3 | 30.3 | 30.3 |
| 1,500 | 25.3 | 4 | 25.3 | 25.3 | 25.3 |
| 1,750 | 21.7 | 6 | 21.7 | 21.7 | 21.7 |
| 2,000 | 18.9 | 9 | 18.9 | 18.9 | 18.4 |
| 2,500 | 15.2 | 13 | 15.2 | 15.2 | 11.7 |
| 3,000 | 12.6 | 18 | 12.6 | 12.2 | 8.2 |
| 3,500 | 10.9 | 23 | 10.9 | 9.0 | 6.0 |
| 4,000 | 9.5 | 29 | 9.2 | 6.9 | 4.6 |
| 4,500 | 8.5 | 36 | 7.2 | 5.4 | 3.6 |
| 5,000 | 7.6 | 52 | 5.9 | 4.4 | 2.9 |
| 6,000 | 6.3 | 77 | 4.1 | 3.1 | 2.0 |

P1001 C41 - COLUMN LOADING (METRIC)

| Unbraced Height mm | Maximum Allowable Load at Slot Face kN | Maximum Column Load Applied at C.G. | | | |
|--------------------------|--|-------------------------------------|----------------|---------------|---------------|
| | | K = 0.65 kN | K = 0.80 kN | K = 1.0 kN | K = 1.2 kN |
| 600 | 56.5 | 209.3 | 200.8 | 189.3 | 178.4 |
| 750 | 55.6 | 200.1 | 189.3 | 175.8 | 164.1 |
| 1,000 | 53.9 | 184.7 | 171.7 | 157.3 | 146.1 |
| 1,250 | 52.4 | 170.7 | 157.3 | 143.8 | 134.1 |
| 1,500 | 51.1 | 158.9 | 146.1 | 134.1 | 126.1 |
| 1,750 | 50.0 | 149.3 | 137.6 | 127.3 | 120.7 |
| 2,000 | 49.2 | 141.5 | 131.1 | 122.3 | 116.8 |
| 2,250 | 47.9 | 135.4 | 126.1 | 118.6 | 101.9 |
| 2,500 | 46.8 | 130.4 | 122.3 | 114.5 | 83.9 |
| 2,750 | 45.9 | 126.4 | 119.2 | 98.8 | 69.4 |

P1004 A - COLUMN LOADING (METRIC)

| Unbraced Height mm | Maximum Allowable Load at Slot Face kN | Maximum Column Load Applied at C.G. | | | |
|--------------------------|--|-------------------------------------|----------------|---------------|---------------|
| | | K = 0.65 kN | K = 0.80 kN | K = 1.0 kN | K = 1.2 kN |
| 600 | 50.9 | 164.6 | 151.8 | 136.5 | 123.8 |
| 750 | 49.1 | 150.8 | 136.5 | 121.1 | 109.5 |
| 1,000 | 46.3 | 130.9 | 116.9 | 103.4 | 94.3 |
| 1,250 | 43.5 | 115.8 | 103.4 | 92.6 | 85.8 |
| 1,500 | 40.9 | 104.8 | 94.3 | 85.8 | 80.6 |
| 1,750 | 38.9 | 96.8 | 88.1 | 81.3 | 77.0 |
| 2,000 | 37.1 | 91.0 | 83.7 | 78.1 | 74.8 |
| 2,250 | 35.7 | 86.6 | 80.6 | 75.8 | 60.9 |
| 2,500 | 34.3 | 83.3 | 78.1 | 71.1 | 49.4 |
| 2,750 | 33.1 | 80.7 | 76.2 | 58.8 | 40.8 |

P1001 C41/ P1004 A - ELEMENTS OF SECTION (METRIC)

| Parameter | P1001 C41 | P1004 A |
|------------------------|------------------------|------------------------|
| Area of Section | 14.33 cm ² | 12.68 cm ² |
| Axis 1-1 | | |
| Moment of Inertia (I) | 77.24 cm ⁴ | 169.33 cm ⁴ |
| Section Modulus (S) | 18.71 cm ³ | 27.35 cm ³ |
| Radius of Gyration (r) | 2.32 cm | 3.66 cm |
| Axis 2-2 | | |
| Moment of Inertia (I) | 100.24 cm ⁴ | 45.44 cm ⁴ |
| Section Modulus (S) | 24.29 cm ³ | 19.50 cm ³ |
| Radius of Gyration (r) | 2.64 cm | 1.89 cm |

*Load limited by spot weld shear.

** $K_L/r > 200$

Notes:

- Above loads include the weight of the member. This weight must be deducted to arrive at the net allowable load the beam will support.
- Long span beams should be supported in such a manner as to prevent rotation and twist.
- Allowable uniformly distributed loads are listed for various simple spans, that is, a beam on two supports. If load is concentrated at the center of the span, multiply load from the table by 0.5 and corresponding deflection by 0.8.
- See page 56 for lateral bracing reduction charts.



P1100

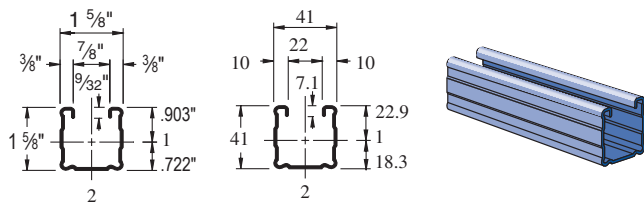

Wt/100 Ft: 142 Lbs (211 kg/100 m)
 Allowable Moment 4,060 In-Lbs (460 N•m)
 14 Gauge Nominal Thickness .075" (1.9mm)

P1101

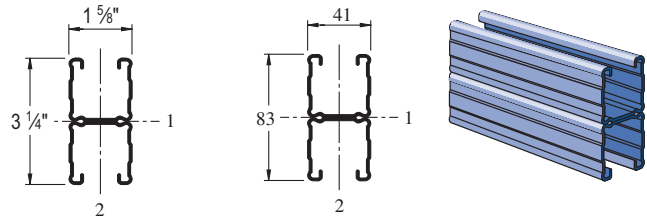

Wt/100 Ft: 284 Lbs (423 kg/100 m)
 Allowable Moment 11,340 In-Lbs (1,280 N•m)
 14 Gauge Nominal Thickness .075" (1.9mm)

P1101 A

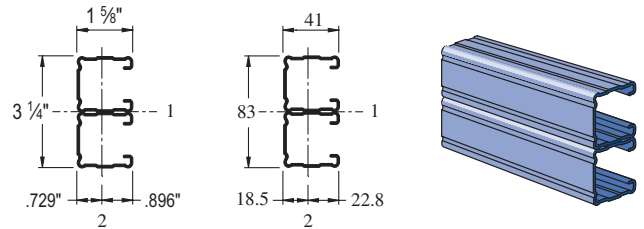

Wt/100 Ft: 284 Lbs (423 kg/100 m)
 Allowable Moment 14,000 In-Lbs (1,580 N•m)
 14 Gauge Nominal Thickness .075" (1.9mm)

P1101 B

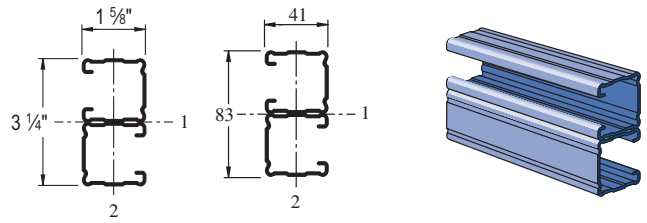

Wt/100 Ft: 284 Lbs (423 kg/100 m)
 Allowable Moment 14,000 In-Lbs (1,580 N•m)
 14 Gauge Nominal Thickness .075" (1.9mm)

P1101 C

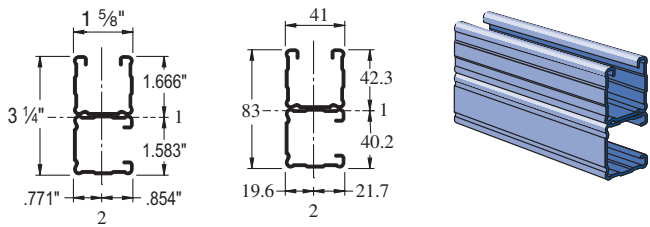

Wt/100 Ft: 284 Lbs (423 kg/100 m)
 Allowable Moment 12,330 In-Lbs (1,390 N•m)
 14 Gauge Nominal Thickness .075" (1.9mm)

P1100 HS

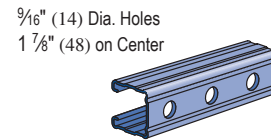

Wt/100 Ft: 136 Lbs (202 kg/100 m)

P1100 KO

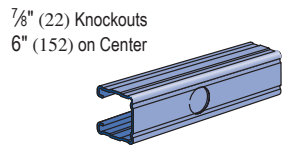

Wt/100 Ft: 140 Lbs (208 kg/100 m)

P1100 SL

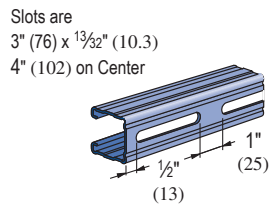

Wt/100 Ft: 136 Lbs (202 kg/100 m)

P1100 T

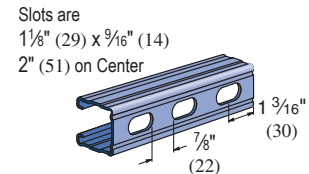

Wt/100 Ft: 136 Lbs (202 kg/100 m)

CHANNEL NUTS (REFER TO HARDWARE SECTION FOR DETAILS)

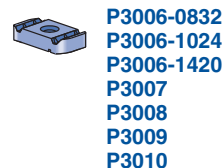
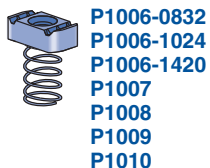

Channel Finishes: PL, GR, HG, PG; Standard Lengths: 10' & 20'

1 5/8" Channel
 Telestrut System
 Nuts & Hardware
 General Fittings
 Pipe/Conduit Supports
 Electrical Fittings
 Concrete Inserts
 1 1/4" Framing System
 1 3/16" Framing System
 Fiberglass System
 Special Metals
 PrimeAngle System
 Product Index

P1100 - BEAM LOADING

| Span In | Max Allowable Uniform Load Lbs | Defl. at Uniform Load In | Uniform Loading at Deflection | | |
|---------|--------------------------------|--------------------------|-------------------------------|--------------|--------------|
| | | | Span/180 Lbs | Span/240 Lbs | Span/360 Lbs |
| 24 | 1,350 | 0.06 | 1,350 | 1,350 | 1,350 |
| 36 | 900 | 0.13 | 900 | 900 | 700 |
| 48 | 680 | 0.23 | 680 | 590 | 400 |
| 60 | 540 | 0.36 | 510 | 380 | 250 |
| 72 | 450 | 0.51 | 350 | 260 | 180 |
| 84 | 390 | 0.70 | 260 | 190 | 130 |
| 96 | 340 | 0.92 | 200 | 150 | 100 |
| 108 | 300 | 1.15 | 160 | 120 | 80 |
| 120 | 270 | 1.42 | 130 | 90 | 60 |
| 144 | 230 | 2.09 | 90 | 70 | 40 |
| 168 | 190 | 2.75 | 60 | 50 | 30 |
| 192 | 170 | 3.67 | 50 | 40 | NR |
| 216 | 150 | 4.61 | 40 | 30 | NR |
| 240 | 140 | 5.90 | 30 | NR | NR |

P1101 - BEAM LOADING

| Span In | Max Allowable Uniform Load Lbs | Defl. at Uniform Load In | Uniform Loading at Deflection | | |
|---------|--------------------------------|--------------------------|-------------------------------|--------------|--------------|
| | | | Span/180 Lbs | Span/240 Lbs | Span/360 Lbs |
| 24 | 2,180* | 0.02 | 2,180* | 2,180* | 2,180* |
| 36 | 2,180* | 0.06 | 2,180* | 2,180* | 2,180* |
| 48 | 1,890 | 0.13 | 1,890 | 1,890 | 1,890 |
| 60 | 1,510 | 0.20 | 1,510 | 1,510 | 1,280 |
| 72 | 1,260 | 0.28 | 1,260 | 1,260 | 890 |
| 84 | 1,080 | 0.39 | 1,080 | 980 | 650 |
| 96 | 950 | 0.51 | 950 | 750 | 500 |
| 108 | 840 | 0.64 | 790 | 590 | 400 |
| 120 | 760 | 0.79 | 640 | 480 | 320 |
| 144 | 630 | 1.13 | 440 | 330 | 220 |
| 168 | 540 | 1.54 | 330 | 250 | 160 |
| 192 | 470 | 2.00 | 250 | 190 | 130 |
| 216 | 420 | 2.55 | 200 | 150 | 100 |
| 240 | 380 | 3.16 | 160 | 120 | 80 |

P1100 - COLUMN LOADING

| Unbraced Height In | Maximum Allowable Load at Slot Face Lbs | Maximum Column Load Applied at C.G. | | | |
|--------------------|---|-------------------------------------|--------------|-------------|-------------|
| | | K = 0.65 Lbs | K = 0.80 Lbs | K = 1.0 Lbs | K = 1.2 Lbs |
| 24 | 2,800 | 8,040 | 7,330 | 6,360 | 5,430 |
| 36 | 2,410 | 6,480 | 5,430 | 4,190 | 3,210 |
| 48 | 1,940 | 4,990 | 3,830 | 2,760 | 2,160 |
| 60 | 1,550 | 3,740 | 2,760 | 2,050 | 1,640 |
| 72 | 1,290 | 2,860 | 2,160 | 1,640 | 1,320 |
| 84 | 1,100 | 2,310 | 1,780 | 1,370 | 1,110 |
| 96 | 950 | 1,950 | 1,520 | 1,180 | 950 |
| 108 | 840 | 1,690 | 1,320 | 1,030 | ** |
| 120 | 760 | 1,490 | 1,180 | ** | ** |
| 144 | 630 | 1,210 | 950 | ** | ** |

P1101 - COLUMN LOADING

| Unbraced Height In | Maximum Allowable Load at Slot Face Lbs | Maximum Column Load Applied at C.G. | | | |
|--------------------|---|-------------------------------------|--------------|-------------|-------------|
| | | K = 0.65 Lbs | K = 0.80 Lbs | K = 1.0 Lbs | K = 1.2 Lbs |
| 24 | 5,010 | 18,250 | 17,700 | 16,880 | 16,030 |
| 36 | 4,860 | 16,990 | 16,030 | 14,770 | 13,620 |
| 48 | 4,700 | 15,610 | 14,380 | 12,930 | 11,750 |
| 60 | 4,480 | 14,280 | 12,930 | 11,490 | 9,290 |
| 72 | 4,210 | 13,100 | 11,750 | 9,290 | 6,700 |
| 84 | 3,880 | 12,090 | 10,220 | 7,090 | 4,930 |
| 96 | 3,480 | 11,170 | 8,390 | 5,430 | 3,770 |
| 108 | 3,060 | 9,640 | 6,700 | 4,290 | 2,980 |
| 120 | 2,680 | 8,170 | 5,430 | 3,480 | ** |
| 144 | 2,090 | 5,710 | 3,770 | ** | ** |

P1100/P1101 - ELEMENTS OF SECTION

| Parameter | P1100 | | P1101 | |
|------------------------|-------|-----------------|-------|-----------------|
| Area of Section | 0.418 | In ² | 0.835 | In ² |
| Axis 1-1 | | | | |
| Moment of Inertia (I) | 0.145 | In ⁴ | 0.733 | In ⁴ |
| Section Modulus (S) | 0.162 | In ³ | 0.451 | In ³ |
| Radius of Gyration (r) | 0.589 | In | 0.937 | In |
| Axis 2-2 | | | | |
| Moment of Inertia (I) | 0.176 | In ⁴ | 0.353 | In ⁴ |
| Section Modulus (S) | 0.217 | In ³ | 0.434 | In ³ |
| Radius of Gyration (r) | 0.650 | In | 0.650 | In |

Notes:

* Load limited by spot weld shear.

** $KL/r > 200$

NR = Not Recommended.

- Above loads include the weight of the member. This weight must be deducted to arrive at the net allowable load the beam will support.
- Long span beams should be supported in such a manner as to prevent rotation and twist.
- Allowable uniformly distributed loads are listed for various simple spans, that is, a beam on two supports. If load is concentrated at the center of the span, multiply load from the table by 0.5 and corresponding deflection by 0.8.
- See page 56 for lateral bracing reduction charts.
- For Pierced Channel, Beam Load Values in the tables are multiplied by the following factor:

"T" Series ... 85% "KO" Series... 95%
 "SL" Series ... 85% "HS" Series... 90%



P1100 - BEAM LOADING (METRIC)

| Span mm | Max Allowable Uniform Load kN | Defl. at Uniform Load mm | Uniform Loading at Deflection | | |
|------------|--|-----------------------------------|-------------------------------|----------------|----------------|
| | | | Span/180 kN | Span/240 kN | Span/360 kN |
| 600 | 6.1 | 1 | 6.1 | 6.1 | 6.1 |
| 750 | 4.9 | 2 | 4.9 | 4.9 | 4.7 |
| 1,000 | 3.7 | 4 | 3.7 | 3.7 | 2.6 |
| 1,250 | 2.9 | 6 | 2.9 | 2.5 | 1.7 |
| 1,500 | 2.4 | 9 | 2.3 | 1.7 | 1.2 |
| 1,750 | 2.1 | 12 | 1.7 | 1.3 | 0.8 |
| 2,000 | 1.8 | 15 | 1.3 | 1.0 | 0.7 |
| 2,500 | 1.5 | 24 | 0.8 | 0.6 | 0.4 |
| 3,000 | 1.2 | 36 | 0.6 | 0.4 | 0.3 |
| 3,500 | 1.1 | 49 | 0.4 | 0.3 | 0.2 |
| 4,000 | 0.9 | 64 | 0.3 | 0.3 | 0.2 |
| 4,500 | 0.8 | 77 | 0.3 | 0.2 | 0.1 |
| 5,000 | 0.8 | 100 | 0.2 | 0.2 | NR |
| 6,000 | 0.6 | 143 | 0.1 | NR | NR |

P1101 - BEAM LOADING (METRIC)

| Span mm | Max Allowable Uniform Load kN | Defl. at Uniform Load mm | Uniform Loading at Deflection | | |
|------------|--|-----------------------------------|-------------------------------|----------------|----------------|
| | | | Span/180 kN | Span/240 kN | Span/360 kN |
| 600 | 9.7 * | 0 | 9.7 * | 9.7 * | 9.7 * |
| 750 | 9.7 * | 1 | 9.7 * | 9.7 * | 9.7 * |
| 1,000 | 9.7 * | 2 | 9.7 * | 9.7 * | 9.7 * |
| 1,250 | 8.2 | 3 | 8.2 | 8.2 | 8.2 |
| 1,500 | 6.9 | 5 | 6.9 | 6.9 | 5.9 |
| 1,750 | 5.9 | 7 | 5.9 | 5.9 | 4.3 |
| 2,000 | 5.1 | 9 | 5.1 | 5.0 | 3.3 |
| 2,500 | 4.1 | 13 | 4.1 | 3.2 | 2.1 |
| 3,000 | 3.4 | 19 | 2.9 | 2.2 | 1.5 |
| 3,500 | 2.9 | 26 | 2.2 | 1.6 | 1.1 |
| 4,000 | 2.6 | 35 | 1.6 | 1.2 | 0.8 |
| 4,500 | 2.3 | 43 | 1.3 | 1.0 | 0.7 |
| 5,000 | 2.0 | 54 | 1.1 | 0.8 | 0.5 |
| 6,000 | 1.7 | 77 | 0.8 | 0.5 | 0.4 |

P1100 - COLUMN LOADING (METRIC)

| Unbraced Height mm | Maximum Allowable Load at Slot Face kN | Maximum Column Load Applied at C.G. | | | |
|--------------------------|--|-------------------------------------|----------------|---------------|---------------|
| | | K = 0.65 kN | K = 0.80 kN | K = 1.0 kN | K = 1.2 kN |
| 600 | 12.5 | 35.9 | 32.9 | 28.6 | 24.5 |
| 750 | 11.8 | 32.6 | 28.6 | 23.5 | 19.0 |
| 1,000 | 10.1 | 26.9 | 22.0 | 16.4 | 12.5 |
| 1,250 | 8.5 | 21.6 | 16.4 | 11.8 | 9.3 |
| 1,500 | 7.0 | 17.0 | 12.5 | 9.3 | 7.4 |
| 1,750 | 6.0 | 13.5 | 10.1 | 7.7 | 6.2 |
| 2,000 | 5.2 | 11.2 | 8.6 | 6.5 | 5.3 |
| 2,250 | 4.6 | 9.6 | 7.4 | 5.7 | 4.7 |
| 2,500 | 4.1 | 8.4 | 6.5 | 5.1 | ** |
| 2,750 | 3.7 | 7.5 | 5.9 | 4.5 | ** |

P1101 - COLUMN LOADING (METRIC)

| Unbraced Height mm | Maximum Allowable Load at Slot Face kN | Maximum Column Load Applied at C.G. | | | |
|--------------------------|--|-------------------------------------|----------------|---------------|---------------|
| | | K = 0.65 kN | K = 0.80 kN | K = 1.0 kN | K = 1.2 kN |
| 600 | 22.3 | 81.4 | 79.0 | 75.4 | 71.7 |
| 750 | 22.0 | 78.7 | 75.4 | 70.7 | 66.1 |
| 1,000 | 21.4 | 73.8 | 69.2 | 63.3 | 58.0 |
| 1,250 | 20.8 | 68.8 | 63.3 | 56.8 | 51.6 |
| 1,500 | 20.0 | 64.0 | 58.0 | 51.6 | 42.3 |
| 1,750 | 19.0 | 59.5 | 53.5 | 44.0 | 32.6 |
| 2,000 | 18.0 | 55.6 | 49.2 | 35.7 | 25.0 |
| 2,250 | 16.6 | 52.3 | 42.3 | 28.4 | 19.7 |
| 2,500 | 15.1 | 48.3 | 35.7 | 23.0 | 16.0 |
| 2,750 | 13.6 | 42.7 | 29.7 | 19.0 | 13.2 |

P1100/P1101 - ELEMENTS OF SECTION (METRIC)

| Parameter | P1100 | | P1101 | |
|------------------------|-------|-----------------|-------|-----------------|
| Area of Section | 2.69 | cm ² | 5.39 | cm ² |
| Axis 1-1 | | | | |
| Moment of Inertia (I) | 6.03 | cm ⁴ | 30.51 | cm ⁴ |
| Section Modulus (S) | 2.65 | cm ³ | 7.39 | cm ³ |
| Radius of Gyration (r) | 1.50 | cm | 2.38 | cm |
| Axis 2-2 | | | | |
| Moment of Inertia (I) | 7.34 | cm ⁴ | 14.69 | cm ⁴ |
| Section Modulus (S) | 3.56 | cm ³ | 7.12 | cm ³ |
| Radius of Gyration (r) | 1.65 | cm | 1.65 | cm |

Notes:

* Load limited by spot weld shear.

** $K_{L/i} > 200$

NR = Not Recommended.

- Above loads include the weight of the member. This weight must be deducted to arrive at the net allowable load the beam will support.
- Long span beams should be supported in such a manner as to prevent rotation and twist.
- Allowable uniformly distributed loads are listed for various simple spans, that is, a beam on two supports. If load is concentrated at the center of the span, multiply load from the table by 0.5 and corresponding deflection by 0.8.
- See page 56 for lateral bracing reduction charts.
- For Pierced Channel, Beam Load Values in the tables are multiplied by the following factor:

"T" Series ... 85% "KO" Series... 95%
 "SL" Series ... 85% "HS" Series... 90%

P2000

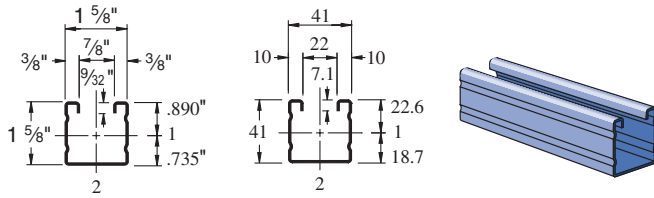

Wt/100 Ft: 116 Lbs (173 kg/100 m)
 Allowable Moment 3,520 In-Lbs (400 N•m)
 16 Gauge Nominal Thickness .060" (1.5mm)

P2001

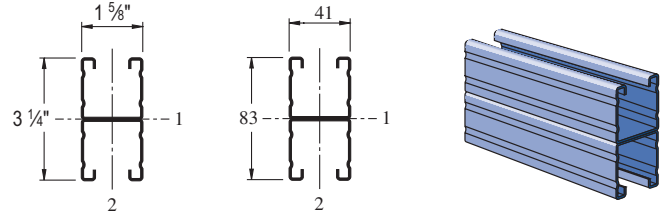

Wt/100 Ft: 232 Lbs (346 kg/100 m)
 Allowable Moment 9,570 In-Lbs (1,080 N•m)
 16 Gauge Nominal Thickness .060" (1.5mm)

P2001 A

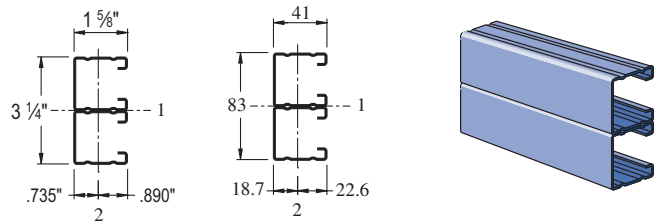

Wt/100 Ft: 232 Lbs (346 kg/100 m)
 Allowable Moment 11,660 In-Lbs (1,320 N•m)
 16 Gauge Nominal Thickness .060" (1.5mm)

P2001 B

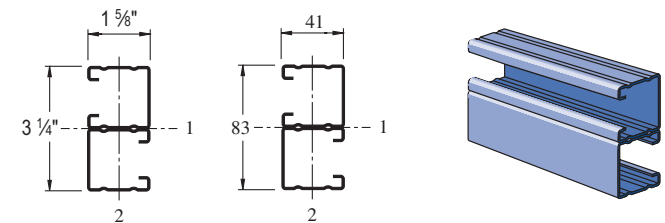

Wt/100 Ft: 232 Lbs (346 kg/100 m)
 Allowable Moment 11,660 In-Lbs (1,320 N•m)
 16 Gauge Nominal Thickness .060" (1.5mm)

P2001 C

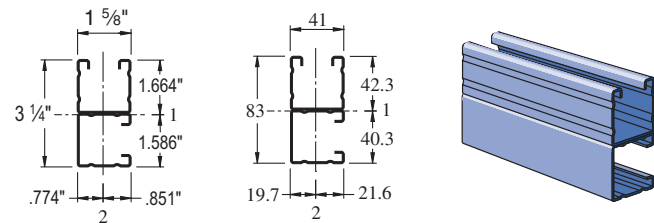

Wt/100 Ft: 232 Lbs (346 kg/100 m)
 Allowable Moment 10,350 In-Lbs (1,170 N•m)
 16 Gauge Nominal Thickness .060" (1.5mm)

P2000 HS

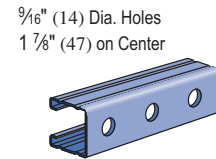

Wt/100 Ft: 113 Lbs (168 kg/100 m)

P2000 KO

7/8" (22) Knockouts
 6" (152) on Center

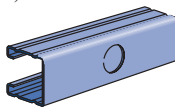

Wt/100 Ft: 117 Lbs (174 kg/100 m)

P2000 SL

Slots are
 3" (76) x 1 3/32" (10.3)
 4" (102) on Center

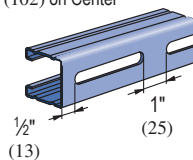

Wt/100 Ft: 113 Lbs (168 kg/100 m)

P2000 T

Slots are
 1 1/8" (29) x 9/16" (14)
 2" (51) on Center

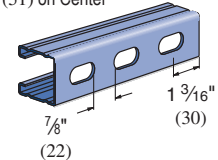

Wt/100 Ft: 113 Lbs (168 kg/100 m)

CHANNEL NUTS (REFER TO HARDWARE SECTION FOR DETAILS)

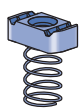

P1006-0832
P1006-1024
P1006-1420
P1007
P1008
P1009
P1010



P1008T
P1006T1420
P1010T



P1024
P1012S
P1023S



P1012
P1023
P1024S



P3006-0832
P3006-1024
P3006-1420
P3007
P3008
P3009
P3010



P3016-0632
P3016-0832
P3016-1024
P3016-1420

Channel Finishes: PL, GR, HG, PG; Standard Lengths: 10' & 20'



P2000 - BEAM LOADING

| Span In | Max Allowable Uniform Load Lbs | Defl. at Uniform Load In | Uniform Loading at Deflection | | |
|---------|--------------------------------|--------------------------|-------------------------------|--------------|--------------|
| | | | Span/180 Lbs | Span/240 Lbs | Span/360 Lbs |
| 24 | 1,170 | 0.06 | 1,170 | 1,170 | 1,170 |
| 36 | 780 | 0.13 | 780 | 780 | 610 |
| 48 | 590 | 0.23 | 590 | 510 | 340 |
| 60 | 470 | 0.36 | 440 | 330 | 220 |
| 72 | 390 | 0.52 | 300 | 230 | 150 |
| 84 | 340 | 0.71 | 220 | 170 | 110 |
| 96 | 290 | 0.91 | 170 | 130 | 90 |
| 108 | 260 | 1.16 | 130 | 100 | 70 |
| 120 | 230 | 1.41 | 110 | 80 | 50 |
| 144 | 200 | 2.12 | 80 | 60 | 40 |
| 168 | 170 | 2.86 | 60 | 40 | 30 |
| 192 | 150 | 3.76 | 40 | 30 | 20 |
| 216 | 130 | 4.64 | 30 | 30 | NR |
| 240 | 120 | 5.88 | 30 | NR | NR |

P2001 - BEAM LOADING

| Span In | Max Allowable Uniform Load Lbs | Defl. at Uniform Load In | Uniform Loading at Deflection | | |
|---------|--------------------------------|--------------------------|-------------------------------|--------------|--------------|
| | | | Span/180 Lbs | Span/240 Lbs | Span/360 Lbs |
| 24 | 1,610* | 0.02 | 1,610* | 1,610* | 1,610* |
| 36 | 1,610* | 0.05 | 1,610* | 1,610* | 1,610* |
| 48 | 1,600 | 0.13 | 1,600 | 1,600 | 1,600 |
| 60 | 1,280 | 0.20 | 1,280 | 1,280 | 1,080 |
| 72 | 1,060 | 0.28 | 1,060 | 1,060 | 750 |
| 84 | 910 | 0.38 | 910 | 830 | 550 |
| 96 | 800 | 0.51 | 800 | 630 | 420 |
| 108 | 710 | 0.64 | 670 | 500 | 330 |
| 120 | 640 | 0.79 | 540 | 410 | 270 |
| 144 | 530 | 1.13 | 380 | 280 | 190 |
| 168 | 460 | 1.56 | 280 | 210 | 140 |
| 192 | 400 | 2.02 | 210 | 160 | 110 |
| 216 | 350 | 2.52 | 170 | 130 | 80 |
| 240 | 320 | 3.16 | 140 | 100 | 70 |

P2000 - COLUMN LOADING

| Unbraced Height In | Maximum Allowable Load at Slot Face Lbs | Maximum Column Load Applied at C.G. | | | |
|--------------------|---|-------------------------------------|--------------|-------------|-------------|
| | | K = 0.65 Lbs | K = 0.80 Lbs | K = 1.0 Lbs | K = 1.2 Lbs |
| 24 | 2,400 | 6,650 | 6,080 | 5,280 | 4,470 |
| 36 | 2,050 | 5,380 | 4,470 | 3,370 | 2,500 |
| 48 | 1,600 | 4,090 | 3,040 | 2,100 | 1,590 |
| 60 | 1,230 | 2,960 | 2,100 | 1,500 | 1,160 |
| 72 | 970 | 2,190 | 1,590 | 1,160 | 910 |
| 84 | 790 | 1,720 | 1,270 | 950 | 760 |
| 96 | 660 | 1,410 | 1,060 | 800 | 650 |
| 108 | 570 | 1,200 | 910 | 700 | ** |
| 120 | 510 | 1,040 | 800 | 620 | ** |
| 144 | 420 | 830 | 650 | ** | ** |

P2001 - COLUMN LOADING

| Unbraced Height In | Maximum Allowable Load at Slot Face Lbs | Maximum Column Load Applied at C.G. | | | |
|--------------------|---|-------------------------------------|--------------|-------------|-------------|
| | | K = 0.65 Lbs | K = 0.80 Lbs | K = 1.0 Lbs | K = 1.2 Lbs |
| 24 | 4,200 | 15,030 | 14,600 | 13,940 | 13,220 |
| 36 | 4,070 | 14,030 | 13,220 | 12,090 | 10,990 |
| 48 | 3,920 | 12,850 | 11,720 | 10,290 | 9,040 |
| 60 | 3,700 | 11,630 | 10,290 | 8,760 | 7,530 |
| 72 | 3,410 | 10,460 | 9,040 | 7,530 | 5,740 |
| 84 | 3,140 | 9,410 | 7,990 | 6,080 | 4,220 |
| 96 | 2,890 | 8,490 | 7,120 | 4,650 | 3,230 |
| 108 | 2,530 | 7,700 | 5,740 | 3,680 | 2,550 |
| 120 | 2,210 | 6,950 | 4,650 | 2,980 | ** |
| 144 | 1,690 | 4,890 | 3,230 | ** | ** |

P2000/P2001 - ELEMENTS OF SECTION

| Parameter | P2000 | | P2001 | |
|------------------------|-------|-----------------|-------|-----------------|
| Area of Section | 0.342 | ln ² | 0.684 | ln ² |
| Axis 1-1 | | | | |
| Moment of Inertia (I) | 0.125 | ln ⁴ | 0.618 | ln ⁴ |
| Section Modulus (S) | 0.140 | ln ³ | 0.381 | ln ³ |
| Radius of Gyration (r) | 0.604 | ln | 0.951 | ln |
| Axis 2-2 | | | | |
| Moment of Inertia (I) | 0.151 | ln ⁴ | 0.302 | ln ⁴ |
| Section Modulus (S) | 0.186 | ln ³ | 0.372 | ln ³ |
| Radius of Gyration (r) | 0.665 | ln | 0.665 | ln |

Notes:

* Load limited by spot weld shear.

** $K_L/r > 200$

NR = Not Recommended.

- Above loads include the weight of the member. This weight must be deducted to arrive at the net allowable load the beam will support.
- Long span beams should be supported in such a manner as to prevent rotation and twist.
- Allowable uniformly distributed loads are listed for various simple spans, that is, a beam on two supports. If load is concentrated at the center of the span, multiply load from the table by 0.5 and corresponding deflection by 0.8.
- See page 56 for lateral bracing reduction charts.
- For Pierced Channel, Beam Load Values in the tables are multiplied by the following factor:

"T" Series ... 85% "KO" Series... 95%
 "SL" Series ... 85% "HS" Series... 90%

1 5/8" Channel
 Telestrut System
 Nuts & Hardware
 General Fittings
 Pipe/Conduit Supports
 Electrical Fittings
 Concrete Inserts
 1 1/4" Framing System
 1 3/8" Framing System
 Fiberglass System
 Special Metals
 PrimeAngle System
 Product Index

P2000 - BEAM LOADING (METRIC)

| Span mm | Max Allowable Uniform Load kN | Defl. at Uniform Load mm | Uniform Loading at Deflection | | |
|------------|--|-----------------------------------|-------------------------------|----------------|----------------|
| | | | Span/180 kN | Span/240 kN | Span/360 kN |
| 600 | 5.3 | 1 | 5.3 | 5.3 | 5.3 |
| 750 | 4.2 | 2 | 4.2 | 4.2 | 4.0 |
| 1,000 | 3.2 | 4 | 3.2 | 3.2 | 2.3 |
| 1,250 | 2.5 | 6 | 2.5 | 2.2 | 1.4 |
| 1,500 | 2.1 | 9 | 2.0 | 1.5 | 1.0 |
| 1,750 | 1.8 | 12 | 1.5 | 1.1 | 0.8 |
| 2,000 | 1.6 | 16 | 1.1 | 0.8 | 0.6 |
| 2,500 | 1.3 | 25 | 0.7 | 0.5 | 0.4 |
| 3,000 | 1.1 | 36 | 0.5 | 0.4 | 0.3 |
| 3,500 | 0.9 | 47 | 0.4 | 0.3 | 0.2 |
| 4,000 | 0.8 | 63 | 0.3 | 0.2 | 0.1 |
| 4,500 | 0.7 | 80 | 0.2 | 0.2 | 0.1 |
| 5,000 | 0.6 | 96 | 0.2 | 0.1 | 0.1 |
| 6,000 | 0.5 | 142 | 0.1 | NR | NR |

P2001 - BEAM LOADING (METRIC)

| Span mm | Max Allowable Uniform Load kN | Defl. at Uniform Load mm | Uniform Loading at Deflection | | |
|------------|--|-----------------------------------|-------------------------------|----------------|----------------|
| | | | Span/180 kN | Span/240 kN | Span/360 kN |
| 600 | 7.2 * | 0 | 7.2 * | 7.2 * | 7.2 * |
| 750 | 7.2 * | 1 | 7.2 * | 7.2 * | 7.2 * |
| 1,000 | 7.2 * | 2 | 7.2 * | 7.2 * | 7.2 * |
| 1,250 | 6.9 | 3 | 6.9 | 6.9 | 6.9 |
| 1,500 | 5.8 | 5 | 5.8 | 5.8 | 5.0 |
| 1,750 | 4.9 | 7 | 4.9 | 4.9 | 3.6 |
| 2,000 | 4.3 | 9 | 4.3 | 4.2 | 2.8 |
| 2,500 | 3.5 | 13 | 3.5 | 2.7 | 1.8 |
| 3,000 | 2.9 | 19 | 2.5 | 1.9 | 1.2 |
| 3,500 | 2.5 | 27 | 1.8 | 1.4 | 0.9 |
| 4,000 | 2.2 | 35 | 1.4 | 1.1 | 0.7 |
| 4,500 | 1.9 | 43 | 1.1 | 0.8 | 0.5 |
| 5,000 | 1.7 | 54 | 0.9 | 0.7 | 0.4 |
| 6,000 | 1.4 | 76 | 0.6 | 0.4 | 0.3 |

P2000 - COLUMN LOADING (METRIC)

| Unbraced Height mm | Maximum Allowable Load at Slot Face kN | Maximum Column Load Applied at C.G. | | | |
|--------------------------|--|-------------------------------------|----------------|---------------|---------------|
| | | K = 0.65 kN | K = 0.80 kN | K = 1.0 kN | K = 1.2 kN |
| 600 | 10.7 | 29.8 | 27.3 | 23.8 | 20.2 |
| 750 | 10.1 | 27.0 | 23.8 | 19.3 | 15.3 |
| 1,000 | 8.5 | 22.3 | 18.0 | 12.9 | 9.6 |
| 1,250 | 6.9 | 17.6 | 12.9 | 9.0 | 6.8 |
| 1,500 | 5.6 | 13.5 | 9.6 | 6.8 | 5.2 |
| 1,750 | 4.6 | 10.5 | 7.6 | 5.5 | 4.3 |
| 2,000 | 3.8 | 8.5 | 6.2 | 4.6 | 3.6 |
| 2,250 | 3.3 | 7.1 | 5.2 | 4.0 | 3.2 |
| 2,500 | 2.8 | 6.1 | 4.6 | 3.5 | 2.8 |
| 2,750 | 2.5 | 5.3 | 4.1 | 3.1 | ** |

P2001 - COLUMN LOADING (METRIC)

| Unbraced Height mm | Maximum Allowable Load at Slot Face kN | Maximum Column Load Applied at C.G. | | | |
|--------------------------|--|-------------------------------------|----------------|---------------|---------------|
| | | K = 0.65 kN | K = 0.80 kN | K = 1.0 kN | K = 1.2 kN |
| 600 | 18.7 | 67.0 | 65.1 | 62.2 | 59.1 |
| 750 | 18.4 | 64.9 | 62.2 | 58.3 | 54.2 |
| 1,000 | 17.9 | 61.0 | 56.9 | 51.5 | 46.3 |
| 1,250 | 17.3 | 56.6 | 51.5 | 45.0 | 39.5 |
| 1,500 | 16.5 | 52.1 | 46.3 | 39.5 | 34.0 |
| 1,750 | 15.5 | 47.9 | 41.6 | 34.8 | 27.9 |
| 2,000 | 14.5 | 43.9 | 37.5 | 30.4 | 21.3 |
| 2,250 | 13.6 | 40.2 | 34.0 | 24.3 | 16.9 |
| 2,500 | 12.5 | 37.0 | 30.4 | 19.7 | 13.7 |
| 2,750 | 11.3 | 34.2 | 25.4 | 16.3 | 11.3 |

P2000/P2001 - ELEMENTS OF SECTION (METRIC)

| Parameter | P2000 | P2001 |
|------------------------|----------------------|-----------------------|
| Area of Section | 2.21 cm ² | 4.41 cm ² |
| Axis 1-1 | | |
| Moment of Inertia (I) | 5.19 cm ⁴ | 25.74 cm ⁴ |
| Section Modulus (S) | 2.29 cm ³ | 6.24 cm ³ |
| Radius of Gyration (r) | 1.53 cm | 2.42 cm |
| Axis 2-2 | | |
| Moment of Inertia (I) | 6.29 cm ⁴ | 12.58 cm ⁴ |
| Section Modulus (S) | 3.05 cm ³ | 6.10 cm ³ |
| Radius of Gyration (r) | 1.69 cm | 1.69 cm |

Notes:

* Load limited by spot weld shear.

** $K L_r > 200$

NR = Not Recommended.

- Above loads include the weight of the member. This weight must be deducted to arrive at the net allowable load the beam will support.
- Long span beams should be supported in such a manner as to prevent rotation and twist.
- Allowable uniformly distributed loads are listed for various simple spans, that is, a beam on two supports. If load is concentrated at the center of the span, multiply load from the table by 0.5 and corresponding deflection by 0.8.
- See page 56 for lateral bracing reduction charts.
- For Pierced Channel, Beam Load Values in the tables are multiplied by the following factor:

"T" Series ...85% "KO" Series... 95%
 "SL" Series ...85% "HS" Series... 90%



P3000

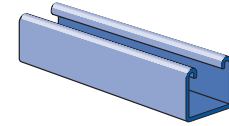
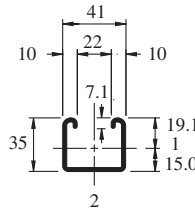
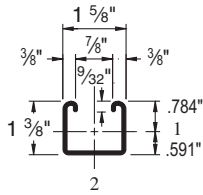

Wt/100 Ft: 170 Lbs (253 kg/100 m)
 Allowable Moment 3,840 In-Lbs (430 N·m)
 12 Gauge Nominal Thickness .105" (2.7mm)

P3001

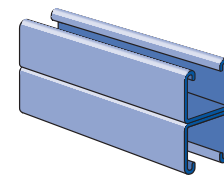
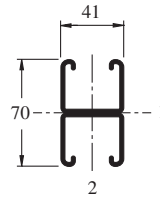
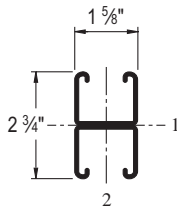

Wt/100 Ft: 340 Lbs (506 kg/100 m)
 Allowable Moment 10,810 In-Lbs (1,220 N·m)
 12 Gauge Nominal Thickness .105" (2.7mm)

P3000 HS

9/16" (14) Dia. Holes
 1 7/8" (48) on Center

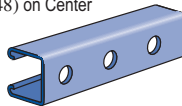

Wt/100 Ft: 165 Lbs (246 kg/100 m)

P3000 KO

7/8" (22) Knockouts
 6" (152) on Center

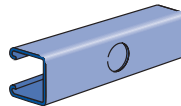

Wt/100 Ft: 170 Lbs (253 kg/100 m)

P3000 SL

Slots are
 3" (76) x 1 3/32" (10.3)
 4" (102) on Center

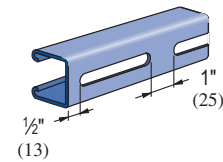

Wt/100 Ft: 165 Lbs (246 kg/100 m)

P3000 T

Slots are
 1 1/8" (29) x 9/16" (14)
 2" (51) on Center

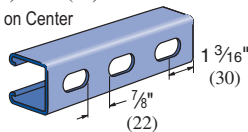

Wt/100 Ft: 165 Lbs (246 kg/100 m)

P3001 T

Slots are
 1 1/8" (29) x 9/16" (14)
 2" (51) on Center

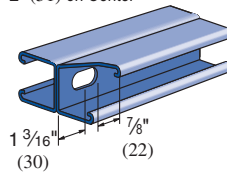

Wt/100 Ft: 340 Lbs (506 kg/100 m)

CHANNEL NUTS (REFER TO HARDWARE SECTION FOR DETAILS)



P1006-0832
P1006-1024
P1006-1420
P1007
P1008
P1009
P1010



P1008T
P1006T1420
P1010T



P1024
P1012S
P1023S



P3006-0832
P3006-1024
P3006-1420
P3007
P3008
P3009
P3010



P3016-0632
P3016-0832
P3016-1024
P3016-1420



P1012
P1023
P1024S

Channel Finishes: PL, GR, HG, PG; Standard Lengths: 10' & 20'

1 1/8" Channel
 Telestrut System
 Nuts & Hardware
 General Fittings
 Pipe/Conduit Supports
 Electrical Fittings
 Concrete Inserts
 1 1/4" Framing System
 1 3/16" Framing System
 Fiberglass System
 Special Metals
 PrimeAngle System
 Product Index

P3000 - BEAM LOADING

| Span In | Max Allowable Uniform Load Lbs | Defl. at Uniform Load In | Uniform Loading at Deflection | | |
|---------|--------------------------------|--------------------------|-------------------------------|--------------|--------------|
| | | | Span/180 Lbs | Span/240 Lbs | Span/360 Lbs |
| 24 | 1,280 | 0.07 | 1,280 | 1,280 | 1,280 |
| 36 | 850 | 0.15 | 850 | 850 | 580 |
| 48 | 640 | 0.26 | 640 | 490 | 330 |
| 60 | 510 | 0.41 | 420 | 310 | 210 |
| 72 | 430 | 0.59 | 290 | 220 | 150 |
| 84 | 370 | 0.81 | 210 | 160 | 110 |
| 96 | 320 | 1.05 | 160 | 120 | 80 |
| 108 | 280 | 1.30 | 130 | 100 | 60 |
| 120 | 260 | 1.66 | 100 | 80 | 50 |
| 144 | 210 | 2.32 | 70 | 50 | 40 |
| 168 | 180 | 3.15 | 50 | 40 | 30 |
| 192 | 160 | 4.18 | 40 | 30 | NR |
| 216 | 140 | 5.21 | NR | NR | NR |
| 240 | 130 | 6.64 | NR | NR | NR |

P3001 - BEAM LOADING

| Span In | Max Allowable Uniform Load Lbs | Defl. at Uniform Load In | Uniform Loading at Deflection | | |
|---------|--------------------------------|--------------------------|-------------------------------|--------------|--------------|
| | | | Span/180 Lbs | Span/240 Lbs | Span/360 Lbs |
| 24 | 2,960* | 0.03 | 2,960* | 2,960* | 2,960* |
| 36 | 2,400 | 0.08 | 2,400 | 2,400 | 2,400 |
| 48 | 1,800 | 0.15 | 1,800 | 1,800 | 1,610 |
| 60 | 1,440 | 0.23 | 1,440 | 1,440 | 1,030 |
| 72 | 1,200 | 0.33 | 1,200 | 1,080 | 720 |
| 84 | 1,030 | 0.46 | 1,030 | 790 | 530 |
| 96 | 900 | 0.59 | 810 | 610 | 400 |
| 108 | 800 | 0.75 | 640 | 480 | 320 |
| 120 | 720 | 0.93 | 520 | 390 | 260 |
| 144 | 600 | 1.34 | 360 | 270 | 180 |
| 168 | 510 | 1.81 | 260 | 200 | 130 |
| 192 | 450 | 2.38 | 200 | 150 | 100 |
| 216 | 400 | 3.01 | 160 | 120 | 80 |
| 240 | 360 | 3.72 | 130 | 100 | NR |

P3000 - COLUMN LOADING

| Unbraced Height In | Maximum Allowable Load at Slot Face Lbs | Maximum Column Load Applied at C.G. | | | |
|--------------------|---|-------------------------------------|--------------|-------------|-------------|
| | | K = 0.65 Lbs | K = 0.80 Lbs | K = 1.0 Lbs | K = 1.2 Lbs |
| 24 | 3,180 | 9,690 | 8,980 | 8,050 | 7,210 |
| 36 | 2,920 | 8,160 | 7,210 | 6,130 | 5,240 |
| 48 | 2,590 | 6,820 | 5,810 | 4,730 | 3,860 |
| 60 | 2,300 | 5,740 | 4,730 | 3,690 | 2,990 |
| 72 | 2,040 | 4,850 | 3,860 | 2,990 | 2,270 |
| 84 | 1,830 | 4,100 | 3,240 | 2,400 | ** |
| 96 | 1,650 | 3,530 | 2,770 | 1,840 | ** |
| 108 | 1,450 | 3,080 | 2,270 | ** | ** |
| 120 | 1,250 | 2,710 | 1,840 | ** | ** |

P3001 - COLUMN LOADING

| Unbraced Height In | Maximum Allowable Load at Slot Face Lbs | Maximum Column Load Applied at C.G. | | | |
|--------------------|---|-------------------------------------|--------------|-------------|-------------|
| | | K = 0.65 Lbs | K = 0.80 Lbs | K = 1.0 Lbs | K = 1.2 Lbs |
| 24 | 5,740 | 21,780 | 21,200 | 20,430 | 19,720 |
| 36 | 5,620 | 20,520 | 19,720 | 18,830 | 17,680 |
| 48 | 5,520 | 19,400 | 18,570 | 16,570 | 14,260 |
| 60 | 5,330 | 18,510 | 16,570 | 13,670 | 10,810 |
| 72 | 5,030 | 16,850 | 14,260 | 10,810 | 7,730 |
| 84 | 4,630 | 14,990 | 11,930 | 8,180 | 5,680 |
| 96 | 4,190 | 13,090 | 9,720 | 6,260 | 4,350 |
| 108 | 3,720 | 11,230 | 7,730 | 4,950 | ** |
| 120 | 3,300 | 9,460 | 6,260 | 4,010 | ** |
| 144 | 2,620 | 6,590 | 4,350 | ** | ** |

P3000/P3001 - ELEMENTS OF SECTION

| Parameter | P3000 | | P3001 | |
|------------------------|-------|-----------------|-------|-----------------|
| Area of Section | 0.500 | In ² | 1.000 | In ² |
| Axis 1-1 | | | | |
| Moment of Inertia (I) | 0.120 | In ⁴ | 0.591 | In ⁴ |
| Section Modulus (S) | 0.153 | In ³ | 0.430 | In ³ |
| Radius of Gyration (r) | 0.489 | In | 0.769 | In |
| Axis 2-2 | | | | |
| Moment of Inertia (I) | 0.203 | In ⁴ | 0.407 | In ⁴ |
| Section Modulus (S) | 0.250 | In ³ | 0.501 | In ³ |
| Radius of Gyration (r) | 0.638 | In | 0.638 | In |

Notes:

* Load limited by spot weld shear.

** $KL_r > 200$

NR = Not Recommended.

- Above loads include the weight of the member. This weight must be deducted to arrive at the net allowable load the beam will support.
- Long span beams should be supported in such a manner as to prevent rotation and twist.
- Allowable uniformly distributed loads are listed for various simple spans, that is, a beam on two supports. If load is concentrated at the center of the span, multiply load from the table by 0.5 and corresponding deflection by 0.8.
- See page 56 for lateral bracing reduction charts.
- For Pierced Channel, Beam Load Values in the tables are multiplied by the following factor:

"T" Series ... 85% "KO" Series... 95%
 "SL" Series ... 85% "HS" Series... 90%



P3000 - BEAM LOADING (METRIC)

| Span mm | Max Allowable Uniform Load kN | Defl. at Uniform Load mm | Uniform Loading at Deflection | | |
|------------|--|-----------------------------------|-------------------------------|----------------|----------------|
| | | | Span/180 kN | Span/240 kN | Span/360 kN |
| 600 | 5.8 | 2 | 5.8 | 5.8 | 5.8 |
| 750 | 4.6 | 3 | 4.6 | 4.6 | 3.8 |
| 1,000 | 3.5 | 4 | 3.5 | 3.2 | 2.2 |
| 1,250 | 2.8 | 7 | 2.8 | 2.1 | 1.4 |
| 1,500 | 2.3 | 10 | 1.9 | 1.4 | 1.0 |
| 1,750 | 2.0 | 14 | 1.4 | 1.1 | 0.7 |
| 2,000 | 1.7 | 18 | 1.1 | 0.8 | 0.5 |
| 2,500 | 1.4 | 28 | 0.7 | 0.5 | 0.4 |
| 3,000 | 1.2 | 40 | 0.5 | 0.4 | 0.2 |
| 3,500 | 1.0 | 54 | 0.4 | 0.3 | 0.2 |
| 4,000 | 0.9 | 73 | 0.3 | 0.2 | 0.1 |
| 4,500 | 0.8 | 89 | 0.2 | 0.2 | NR |
| 5,000 | 0.7 | 115 | 0.2 | 0.1 | NR |
| 6,000 | 0.6 | 161 | NR | NR | NR |

P3001 - BEAM LOADING (METRIC)

| Span mm | Max Allowable Uniform Load kN | Defl. at Uniform Load mm | Uniform Loading at Deflection | | |
|------------|--|-----------------------------------|-------------------------------|----------------|----------------|
| | | | Span/180 kN | Span/240 kN | Span/360 kN |
| 600 | 13.2 * | 1 | 13.2 * | 13.2 * | 13.2 * |
| 750 | 13.0 | 1 | 13.0 | 13.0 | 13.0 |
| 1,000 | 9.8 | 3 | 9.8 | 9.8 | 9.8 |
| 1,250 | 7.8 | 4 | 7.8 | 7.8 | 6.9 |
| 1,500 | 6.5 | 6 | 6.5 | 6.5 | 4.8 |
| 1,750 | 5.6 | 8 | 5.6 | 5.2 | 3.5 |
| 2,000 | 4.9 | 10 | 4.9 | 4.0 | 2.7 |
| 2,500 | 3.9 | 16 | 3.4 | 2.6 | 1.7 |
| 3,000 | 3.2 | 23 | 2.4 | 1.8 | 1.2 |
| 3,500 | 2.8 | 31 | 1.7 | 1.3 | 0.9 |
| 4,000 | 2.4 | 41 | 1.3 | 1.0 | 0.7 |
| 4,500 | 2.2 | 52 | 1.1 | 0.8 | 0.5 |
| 5,000 | 2.0 | 64 | 0.8 | 0.6 | 0.4 |
| 6,000 | 1.6 | 92 | 0.6 | 0.4 | 0.3 |

P3000 - COLUMN LOADING (METRIC)

| Unbraced Height mm | Maximum Allowable Load at Slot Face kN | Maximum Column Load Applied at C.G. | | | |
|--------------------------|--|-------------------------------------|----------------|---------------|---------------|
| | | K = 0.65 kN | K = 0.80 kN | K = 1.0 kN | K = 1.2 kN |
| 600 | 14.2 | 43.3 | 40.2 | 36.1 | 32.4 |
| 750 | 13.6 | 39.9 | 36.1 | 31.5 | 27.6 |
| 1,000 | 12.5 | 34.5 | 30.2 | 25.3 | 21.3 |
| 1,250 | 11.4 | 29.8 | 25.3 | 20.5 | 16.7 |
| 1,500 | 10.3 | 25.8 | 21.3 | 16.7 | 13.6 |
| 1,750 | 9.4 | 22.5 | 18.1 | 14.0 | 11.0 |
| 2,000 | 8.5 | 19.6 | 15.5 | 11.9 | 8.5 |
| 2,250 | 7.8 | 17.2 | 13.6 | 9.6 | ** |
| 2,500 | 7.2 | 15.3 | 11.9 | ** | ** |
| 2,750 | 6.4 | 13.7 | 10.1 | ** | ** |

P3001 - COLUMN LOADING (METRIC)

| Unbraced Height mm | Maximum Allowable Load at Slot Face kN | Maximum Column Load Applied at C.G. | | | |
|--------------------------|--|-------------------------------------|----------------|---------------|---------------|
| | | K = 0.65 kN | K = 0.80 kN | K = 1.0 kN | K = 1.2 kN |
| 600 | 25.5 | 97.1 | 94.5 | 91.1 | 88.0 |
| 750 | 25.3 | 94.3 | 91.1 | 87.3 | 84.0 |
| 1,000 | 24.9 | 89.8 | 86.1 | 82.2 | 74.5 |
| 1,250 | 24.6 | 85.8 | 82.2 | 72.4 | 61.8 |
| 1,500 | 23.8 | 82.6 | 74.5 | 61.8 | 49.2 |
| 1,750 | 22.8 | 77.0 | 66.1 | 51.3 | 37.5 |
| 2,000 | 21.4 | 70.3 | 57.6 | 41.3 | 28.7 |
| 2,250 | 19.9 | 63.4 | 49.2 | 32.7 | 22.7 |
| 2,500 | 18.2 | 56.5 | 41.3 | 26.5 | 18.4 |
| 2,750 | 16.5 | 49.8 | 34.2 | 21.9 | ** |

P3000/P3001 - ELEMENTS OF SECTION (METRIC)

| Parameter | P3000 | | P3001 | |
|------------------------|-------|-----------------|-------|-----------------|
| | Value | Unit | Value | Unit |
| Area of Section | 3.23 | cm ² | 6.45 | cm ² |
| Axis 1-1 | | | | |
| Moment of Inertia (I) | 4.97 | cm ⁴ | 24.61 | cm ⁴ |
| Section Modulus (S) | 2.51 | cm ³ | 7.05 | cm ³ |
| Radius of Gyration (r) | 1.24 | cm | 1.95 | cm |
| Axis 2-2 | | | | |
| Moment of Inertia (I) | 8.47 | cm ⁴ | 16.93 | cm ⁴ |
| Section Modulus (S) | 4.10 | cm ³ | 8.20 | cm ³ |
| Radius of Gyration (r) | 1.62 | cm | 1.62 | cm |

Notes:

* Load limited by spot weld shear.

** $KL/r > 200$

NR = Not Recommended.

- Above loads include the weight of the member. This weight must be deducted to arrive at the net allowable load the beam will support.
- Long span beams should be supported in such a manner as to prevent rotation and twist.
- Allowable uniformly distributed loads are listed for various simple spans, that is, a beam on two supports. If load is concentrated at the center of the span, multiply load from the table by 0.5 and corresponding deflection by 0.8.
- See page 56 for lateral bracing reduction charts.
- For Pierced Channel, Beam Load Values in the tables are multiplied by the following factor:

"T" Series ... 85% "KO" Series... 95%
 "SL" Series ... 85% "HS" Series... 90%

P3300

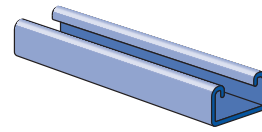
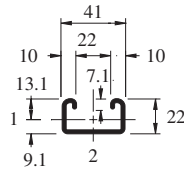
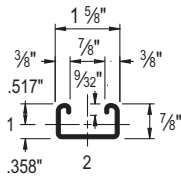

Wt/100 Ft: 134 Lbs (200 kg/100 m)
 Allowable Moment 1,800 In-Lbs (200 N•m)
 12 Gauge Nominal Thickness .105" (2.7mm)

P3301

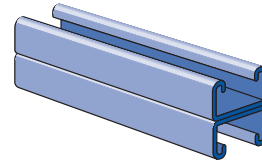
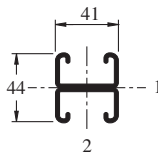
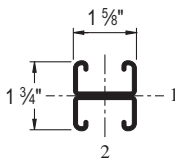

Wt/100 Ft: 269 Lbs (400 kg/100 m)
 Allowable Moment 5,060 In-Lbs (570 N•m)
 12 Gauge Nominal Thickness .105" (2.7mm)

P3300 HS

9/16" (14) Dia. Holes
 1 7/8" (48) on Center

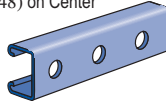

Wt/100 Ft: 130 Lbs (193 kg/100 m)

P3300 T

Slots are
 1 1/8" (29) x 9/16" (14)
 2" (51) on Center

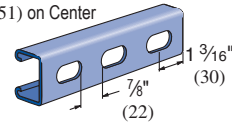

Wt/100 Ft: 130 Lbs (193 kg/100 m)

P3300 SL

Slots are
 3" (76) x 1 3/32" (10.3)
 4" (102) on Center

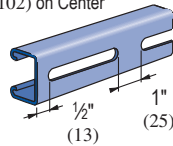

Wt/100 Ft: 130 Lbs (193 kg/100 m)

P3301 T

Slots are
 1 1/8" (29) x 9/16" (14)
 2" (51) on Center

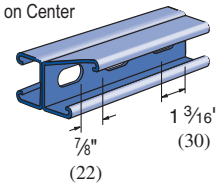

Wt/100 Ft: 270 Lbs (402 kg/100 m)

CHANNEL NUTS (REFER TO HARDWARE SECTION FOR DETAILS)



P4006-0832
 P4006-1024
 P4006-1420
 P4007
 P4008
 P4009
 P4010



P4006T1420
 P4008T
 P4010T



P4012S
 P4023S



P4012
 P4023



P3006-0832
 P3006-1024
 P3006-1420
 P3007
 P3008
 P3009
 P3013



P3016-0632
 P3016-0832
 P3016-1024
 P3016-1420

Channel Finishes: PL, GR, HG, PG; Standard Lengths: 10' & 20'



P3300 - BEAM LOADING

| Span In | Max Allowable Uniform Load Lbs | Defl. at Uniform Load In | Uniform Loading at Deflection | | |
|------------|---|-----------------------------------|-------------------------------|-----------------|-----------------|
| | | | Span/180 Lbs | Span/240 Lbs | Span/360 Lbs |
| 24 | 600 | 0.10 | 600 | 600 | 400 |
| 36 | 400 | 0.22 | 360 | 270 | 180 |
| 48 | 300 | 0.40 | 200 | 150 | 100 |
| 60 | 240 | 0.62 | 130 | 100 | 60 |
| 72 | 200 | 0.89 | 90 | 70 | 40 |
| 84 | 170 | 1.20 | 70 | 50 | 30 |
| 96 | 150 | 1.59 | 50 | 40 | 30 |
| 108 | 130 | 1.96 | 40 | 30 | 20 |
| 120 | 120 | 2.48 | 30 | 20 | 20 |

P3301 - BEAM LOADING

| Span In | Max Allowable Uniform Load Lbs | Defl. at Uniform Load In | Uniform Loading at Deflection | | |
|------------|---|-----------------------------------|-------------------------------|-----------------|-----------------|
| | | | Span/180 Lbs | Span/240 Lbs | Span/360 Lbs |
| 24 | 1,690 | 0.06 | 1,690 | 1,690 | 1,690 |
| 36 | 1,130 | 0.13 | 1,130 | 1,130 | 860 |
| 48 | 840 | 0.23 | 840 | 720 | 480 |
| 60 | 680 | 0.37 | 620 | 460 | 310 |
| 72 | 560 | 0.52 | 430 | 320 | 210 |
| 84 | 480 | 0.71 | 310 | 240 | 160 |
| 96 | 420 | 0.93 | 240 | 180 | 120 |
| 108 | 380 | 1.20 | 190 | 140 | 100 |
| 120 | 340 | 1.47 | 150 | 120 | 80 |
| 144 | 280 | 2.09 | 110 | 80 | 50 |

P3300 - COLUMN LOADING

| Unbraced Height In | Maximum Allowable Load at Slot Face Lbs | Maximum Column Load Applied at C.G. | | | |
|--------------------------|---|-------------------------------------|-----------------|----------------|----------------|
| | | K = 0.65 Lbs | K = 0.80 Lbs | K = 1.0 Lbs | K = 1.2 Lbs |
| 24 | 2,360 | 7,740 | 7,260 | 6,350 | 5,390 |
| 36 | 2,120 | 6,470 | 5,390 | 3,990 | 2,810 |
| 48 | 1,760 | 4,910 | 3,550 | 2,270 | 1,580 |
| 60 | 1,380 | 3,440 | 2,270 | 1,460 | ** |
| 72 | 1,080 | 2,390 | 1,580 | ** | ** |

P3301 - COLUMN LOADING

| Unbraced Height In | Maximum Allowable Load at Slot Face Lbs | Maximum Column Load Applied at C.G. | | | |
|--------------------------|---|-------------------------------------|-----------------|----------------|----------------|
| | | K = 0.65 Lbs | K = 0.80 Lbs | K = 1.0 Lbs | K = 1.2 Lbs |
| 24 | 4,290 | 16,990 | 16,580 | 15,770 | 14,720 |
| 36 | 4,150 | 15,890 | 14,720 | 12,980 | 11,120 |
| 48 | 3,940 | 14,160 | 12,360 | 9,880 | 7,510 |
| 60 | 3,650 | 12,210 | 9,880 | 6,940 | 4,820 |
| 72 | 3,270 | 10,190 | 7,510 | 4,820 | 3,350 |
| 84 | 2,800 | 8,220 | 5,530 | 3,540 | ** |
| 96 | 2,410 | 6,420 | 4,240 | ** | ** |
| 108 | 2,080 | 5,070 | 3,350 | ** | ** |

P3300/P3301 - ELEMENTS OF SECTION

| Parameter | P3300 | | P3301 | |
|------------------------|-------|-----------------|-------|-----------------|
| Area of Section | 0.395 | In ² | 0.790 | In ² |
| Axis 1-1 | | | | |
| Moment of Inertia (I) | 0.037 | In ⁴ | 0.176 | In ⁴ |
| Section Modulus (S) | 0.072 | In ³ | 0.201 | In ³ |
| Radius of Gyration (r) | 0.306 | In | 0.472 | In |
| Axis 2-2 | | | | |
| Moment of Inertia (I) | 0.143 | In ⁴ | 0.285 | In ⁴ |
| Section Modulus (S) | 0.176 | In ³ | 0.351 | In ³ |
| Radius of Gyration (r) | 0.601 | In | 0.601 | In |

Notes:

* Load limited by spot weld shear.

** $KL/r > 200$

- Above loads include the weight of the member. This weight must be deducted to arrive at the net allowable load the beam will support.
- Long span beams should be supported in such a manner as to prevent rotation and twist.
- Allowable uniformly distributed loads are listed for various simple spans, that is, a beam on two supports. If load is concentrated at the center of the span, multiply load from the table by 0.5 and corresponding deflection by 0.8.
- See page 56 for lateral bracing reduction charts.
- For Pierced Channel, Beam Load Values in the tables are multiplied by the following factor:

"T" Series ... 85% "KO" Series... 95%
 "SL" Series ... 85% "HS" Series... 90%

1 1/8" Channel
 Telestrut System
 Nuts & Hardware
 General Fittings
 Pipe/Conduit Supports
 Electrical Fittings
 Concrete Inserts
 1 1/4" Framing System
 1 3/8" Framing System
 Fiberglass System
 Special Metals
 PrimeAngle System
 Product Index

P3300 - BEAM LOADING (METRIC)

| Span mm | Max Allowable Uniform Load kN | Defl. at Uniform Load mm | Uniform Loading at Deflection | | |
|------------|--|-----------------------------------|-------------------------------|----------------|----------------|
| | | | Span/180 kN | Span/240 kN | Span/360 kN |
| 600 | 2.7 | 2 | 2.7 | 2.7 | 1.9 |
| 750 | 2.2 | 4 | 2.2 | 1.8 | 1.2 |
| 1,000 | 1.6 | 7 | 1.3 | 1.0 | 0.7 |
| 1,250 | 1.3 | 10 | 0.8 | 0.6 | 0.4 |
| 1,500 | 1.1 | 15 | 0.6 | 0.4 | 0.3 |
| 1,750 | 0.9 | 21 | 0.4 | 0.3 | 0.2 |
| 2,000 | 0.8 | 27 | 0.3 | 0.3 | 0.2 |
| 2,500 | 0.7 | 43 | 0.2 | 0.2 | 0.1 |
| 3,000 | 0.5 | 60 | 0.1 | 0.1 | 0.1 |
| 3,500 | 0.4 | 79 | 0.1 | 0.1 | NR |

P3301 - BEAM LOADING (METRIC)

| Span mm | Max Allowable Uniform Load kN | Defl. at Uniform Load mm | Uniform Loading at Deflection | | |
|------------|--|-----------------------------------|-------------------------------|----------------|----------------|
| | | | Span/180 kN | Span/240 kN | Span/360 kN |
| 600 | 7.6 | 1 | 7.6 | 7.6 | 7.6 |
| 750 | 6.1 | 2 | 6.1 | 6.1 | 5.6 |
| 1,000 | 4.6 | 4 | 4.6 | 4.6 | 3.2 |
| 1,250 | 3.6 | 6 | 3.6 | 3.1 | 2.0 |
| 1,500 | 3.1 | 9 | 2.8 | 2.1 | 1.4 |
| 1,750 | 2.6 | 12 | 2.1 | 1.6 | 1.0 |
| 2,000 | 2.3 | 16 | 1.6 | 1.2 | 0.8 |
| 2,500 | 1.8 | 25 | 1.0 | 0.8 | 0.5 |
| 3,000 | 1.5 | 36 | 0.7 | 0.5 | 0.4 |
| 3,500 | 1.3 | 48 | 0.5 | 0.4 | 0.3 |
| 4,000 | 1.2 | 65 | 0.4 | 0.3 | 0.2 |

P3300 - COLUMN LOADING (METRIC)

| Unbraced Height mm | Maximum Allowable Load at Slot Face kN | Maximum Column Load Applied at C.G. | | | |
|--------------------------|--|-------------------------------------|----------------|---------------|---------------|
| | | K = 0.65 kN | K = 0.80 kN | K = 1.0 kN | K = 1.2 kN |
| 600 | 10.5 | 34.6 | 32.6 | 28.6 | 24.4 |
| 750 | 10.1 | 32.3 | 28.6 | 23.3 | 18.2 |
| 1,000 | 9.1 | 26.9 | 21.6 | 15.0 | 10.5 |
| 1,250 | 7.6 | 21.2 | 15.0 | 9.6 | 6.7 |
| 1,500 | 6.3 | 15.8 | 10.5 | 6.7 | ** |
| 1,750 | 5.1 | 11.6 | 7.6 | ** | ** |

P3301 - COLUMN LOADING (METRIC)

| Unbraced Height mm | Maximum Allowable Load at Slot Face kN | Maximum Column Load Applied at C.G. | | | |
|--------------------------|--|-------------------------------------|----------------|---------------|---------------|
| | | K = 0.65 kN | K = 0.80 kN | K = 1.0 kN | K = 1.2 kg |
| 600 | 19.1 | 75.7 | 73.9 | 70.5 | 66.0 |
| 750 | 18.9 | 73.8 | 70.5 | 64.7 | 58.4 |
| 1,000 | 18.2 | 68.6 | 62.7 | 53.9 | 44.8 |
| 1,250 | 17.4 | 62.1 | 53.9 | 42.6 | 31.9 |
| 1,500 | 16.4 | 55.0 | 44.8 | 31.9 | 22.2 |
| 1,750 | 15.0 | 47.6 | 36.0 | 23.4 | 16.3 |
| 2,000 | 13.3 | 40.3 | 28.0 | 17.9 | ** |
| 2,250 | 11.8 | 33.4 | 22.2 | 14.1 | ** |
| 2,500 | 10.4 | 27.2 | 17.9 | ** | ** |
| 2,750 | 9.2 | 22.5 | 14.8 | ** | ** |

P3300/P3301 - ELEMENTS OF SECTION (METRIC)

| Parameter | P3300 | P3301 |
|------------------------|----------------------|-----------------------|
| Area of Section | 2.55 cm ² | 5.10 cm ² |
| Axis 1-1 | | |
| Moment of Inertia (I) | 1.54 cm ⁴ | 7.33 cm ⁴ |
| Section Modulus (S) | 1.18 cm ³ | 3.30 cm ³ |
| Radius of Gyration (r) | 0.78 cm | 1.20 cm |
| Axis 2-2 | | |
| Moment of Inertia (I) | 5.94 cm ⁴ | 11.87 cm ⁴ |
| Section Modulus (S) | 2.88 cm ³ | 5.75 cm ³ |
| Radius of Gyration (r) | 1.53 cm | 1.53 cm |

Notes:

* Load limited by spot weld shear.

** $KL_r > 200$

- Above loads include the weight of the member. This weight must be deducted to arrive at the net allowable load the beam will support.
- Long span beams should be supported in such a manner as to prevent rotation and twist.
- Allowable uniformly distributed loads are listed for various simple spans, that is, a beam on two supports. If load is concentrated at the center of the span, multiply load from the table by 0.5 and corresponding deflection by 0.8.
- See page 56 for lateral bracing reduction charts.
- For Pierced Channel, Beam Load Values in the tables are multiplied by the following factor:

"T" Series ... 85% "KO" Series... 95%
 "SL" Series ... 85% "HS" Series... 90%



P4000

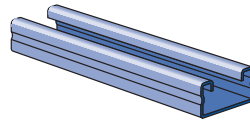
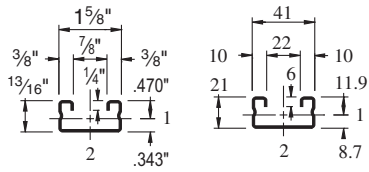

Wt/100 Ft: 83 Lbs (123 kg/100 m)
 Allowable Moment 1,230 In-Lbs (140 N·m)
 16 Gauge Nominal Thickness .060" (1.5mm)

P4001

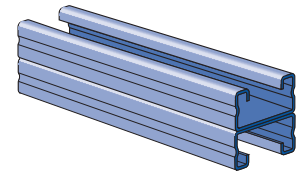
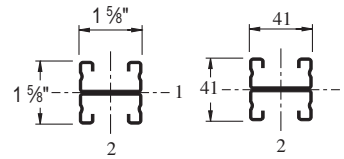

Wt/100 Ft: 166 Lbs (246 kg/100 m)
 Allowable Moment 3,210 In-Lbs (360 N·m)
 16 Gauge Nominal Thickness .060" (1.5mm)

P4003

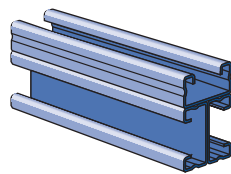
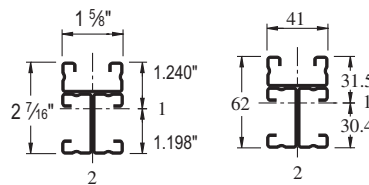

Wt/100 Ft: 248 Lbs (370 kg/100 m)
 Allowable Moment 8,600 In-Lbs (970 N·m)
 16 Gauge Nominal Thickness .060" (1.5mm)

P4004

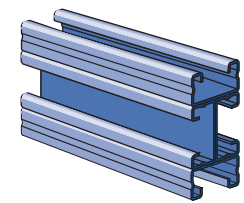
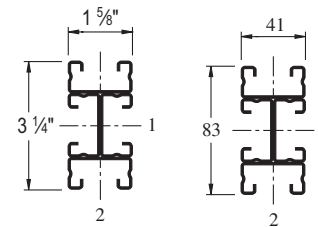

Wt/100 Ft: 331 Lbs (493 kg/100 m)
 Allowable Moment 13,650 In-Lbs (1,540 N·m)
 16 Gauge Nominal Thickness .060" (1.5mm)

P4000 HS

9/16" (14) Dia. Holes
 1 7/8" (48) on Center

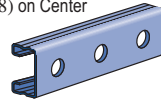

Wt/100 Ft: 79 Lbs (118 kg/100 m)

P4000 T

Slots are
 1 1/8" (29) x 9/16" (14)
 2" (51) on Center

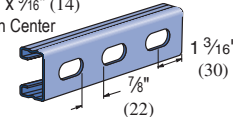

Wt/100 Ft: 79 Lbs (118 kg/100 m)

P4000 SL

Slots are
 3" (76) x 1 3/32" (10.3)
 4" (102) on Center

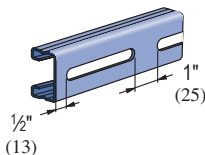

Wt/100 Ft: 79 Lbs (118 kg/100 m)

CHANNEL NUTS (REFER TO HARDWARE SECTION FOR DETAILS)



P4006-0832
P4006-1024
P4006-1420
P4007
P4008
P4009
P4010



P4006T1420
P4008T
P4010T



P4012S
P4023S



P3006-0832
P3006-1024
P3006-1420
P3007
P3008
P3009
P3013



P3016-0632
P3016-0832
P3016-1024
P3016-1420



P4012
P4023

Channel Finishes: PL, GR, HG, PG; Standard Lengths: 10' & 20'

1 5/8" Channel
 Telesit System
 Nuts & Hardware
 General Fittings
 Pipe/Conduit Supports
 Electrical Fittings
 Concrete Inserts
 1 1/4" Framing System
 1 3/16" Framing System
 Fiberglass System
 Special Metals
 PrimeAngle System
 Product Index

P4000 - BEAM LOADING

| Span In | Max Allowable Uniform Load Lbs | Defl. at Uniform Load In | Uniform Loading at Deflection | | |
|---------|--------------------------------|--------------------------|-------------------------------|--------------|--------------|
| | | | Span/180 Lbs | Span/240 Lbs | Span/360 Lbs |
| 24 | 410 | 0.11 | 410 | 370 | 250 |
| 36 | 270 | 0.24 | 220 | 170 | 110 |
| 48 | 200 | 0.43 | 120 | 90 | 60 |
| 60 | 160 | 0.67 | 80 | 60 | 40 |
| 72 | 140 | 1.01 | 60 | 40 | 30 |
| 84 | 120 | 1.38 | 40 | 30 | 20 |
| 96 | 100 | 1.72 | 30 | 20 | 20 |
| 108 | 90 | 2.20 | 20 | 20 | 10 |
| 120 | 80 | 2.68 | 20 | 10 | 10 |

P4001 - BEAM LOADING

| Span In | Max Allowable Uniform Load Lbs | Defl. at Uniform Load In | Uniform Loading at Deflection | | |
|---------|--------------------------------|--------------------------|-------------------------------|--------------|--------------|
| | | | Span/180 Lbs | Span/240 Lbs | Span/360 Lbs |
| 24 | 810* | 0.05 | 810* | 810* | 810* |
| 36 | 710 | 0.14 | 710 | 710 | 500 |
| 48 | 540 | 0.25 | 540 | 430 | 280 |
| 60 | 430 | 0.40 | 360 | 270 | 180 |
| 72 | 360 | 0.57 | 250 | 190 | 130 |
| 84 | 310 | 0.78 | 190 | 140 | 90 |
| 96 | 270 | 1.02 | 140 | 110 | 70 |
| 108 | 240 | 1.29 | 110 | 80 | 60 |
| 120 | 210 | 1.54 | 90 | 70 | 50 |
| 144 | 180 | 2.29 | 60 | 50 | 30 |

P4000 - COLUMN LOADING

| Unbraced Height In | Maximum Allowable Load at Slot Face Lbs | Maximum Column Load Applied at C.G. | | | |
|--------------------|---|-------------------------------------|--------------|-------------|-------------|
| | | K = 0.65 Lbs | K = 0.80 Lbs | K = 1.0 Lbs | K = 1.2 Lbs |
| 24 | 1,630 | 4,670 | 4,290 | 3,780 | 3,310 |
| 36 | 1,450 | 3,840 | 3,310 | 2,460 | 1,730 |
| 48 | 1,160 | 3,030 | 2,190 | 1,400 | 970 |
| 60 | 870 | 2,120 | 1,400 | 900 | ** |
| 72 | 670 | 1,470 | 970 | ** | ** |

P4001 - COLUMN LOADING

| Unbraced Height In | Maximum Allowable Load at Slot Face Lbs | Maximum Column Load Applied at C.G. | | | |
|--------------------|---|-------------------------------------|--------------|-------------|-------------|
| | | K = 0.65 Lbs | K = 0.80 Lbs | K = 1.0 Lbs | K = 1.2 Lbs |
| 24 | 2,830 | 10,390 | 10,000 | 9,470 | 8,960 |
| 36 | 2,740 | 9,530 | 8,960 | 7,870 | 6,700 |
| 48 | 2,590 | 8,620 | 7,480 | 5,910 | 4,440 |
| 60 | 2,340 | 7,380 | 5,910 | 4,090 | 2,840 |
| 72 | 2,020 | 6,110 | 4,440 | 2,840 | 1,970 |
| 84 | 1,700 | 4,880 | 3,260 | 2,090 | ** |
| 96 | 1,440 | 3,780 | 2,500 | ** | ** |
| 108 | 1,230 | 2,990 | 1,970 | ** | ** |

P4000/P4001 - ELEMENTS OF SECTION

| Parameter | P4000 | | P4001 | |
|------------------------|-------|-----------------|-------|-----------------|
| Area of Section | 0.244 | In ² | 0.487 | In ² |
| Axis 1-1 | | | | |
| Moment of Inertia (I) | 0.023 | In ⁴ | 0.104 | In ⁴ |
| Section Modulus (S) | 0.049 | In ³ | 0.128 | In ³ |
| Radius of Gyration (r) | 0.306 | In | 0.462 | In |
| Axis 2-2 | | | | |
| Moment of Inertia (I) | 0.092 | In ⁴ | 0.183 | In ⁴ |
| Section Modulus (S) | 0.113 | In ³ | 0.225 | In ³ |
| Radius of Gyration (r) | 0.613 | In | 0.613 | In |

Notes:

* Load limited by spot weld shear.

** $KL_r > 200$

- Above loads include the weight of the member. This weight must be deducted to arrive at the net allowable load the beam will support.
- Long span beams should be supported in such a manner as to prevent rotation and twist.
- Allowable uniformly distributed loads are listed for various simple spans, that is, a beam on two supports. If load is concentrated at the center of the span, multiply load from the table by 0.5 and corresponding deflection by 0.8.
- See page 56 for lateral bracing reduction charts.
- For Pierced Channel, Reduce Beam Load Values as Follows:

"T" Series ... 85% "SL" Series... 85%
 "HS" Series ... 90%



P4000 - BEAM LOADING (METRIC)

| Span mm | Max Allowable Uniform Load kN | Defl. at Uniform Load mm | Uniform Loading at Deflection | | |
|------------|--|-----------------------------------|-------------------------------|----------------|----------------|
| | | | Span/180 kN | Span/240 kN | Span/360 kN |
| 600 | 1.9 | 3 | 1.9 | 1.7 | 1.2 |
| 750 | 1.5 | 4 | 1.5 | 1.1 | 0.7 |
| 1,000 | 1.1 | 8 | 0.8 | 0.6 | 0.4 |
| 1,250 | 0.9 | 12 | 0.5 | 0.4 | 0.3 |
| 1,500 | 0.8 | 17 | 0.4 | 0.3 | 0.2 |
| 1,750 | 0.6 | 23 | 0.3 | 0.2 | 0.1 |
| 2,000 | 0.5 | 29 | 0.2 | 0.1 | 0.1 |
| 2,500 | 0.4 | 47 | 0.1 | 0.1 | NR |
| 3,000 | 0.4 | 65 | 0.1 | 0.1 | NR |

P4001 - BEAM LOADING (METRIC)

| Span mm | Max Allowable Uniform Load kN | Defl. at Uniform Load mm | Uniform Loading at Deflection | | |
|------------|--|-----------------------------------|-------------------------------|----------------|----------------|
| | | | Span/180 kN | Span/240 kN | Span/360 kN |
| 600 | 3.6 * | 1 | 3.6 * | 3.6 * | 3.6 * |
| 750 | 3.6 * | 2 | 3.6 * | 3.6 * | 3.3 |
| 1,000 | 2.9 | 4 | 2.9 | 2.8 | 1.9 |
| 1,250 | 2.3 | 7 | 2.3 | 1.8 | 1.2 |
| 1,500 | 2.0 | 10 | 1.6 | 1.2 | 0.8 |
| 1,750 | 1.6 | 13 | 1.2 | 0.9 | 0.6 |
| 2,000 | 1.5 | 17 | 0.9 | 0.7 | 0.5 |
| 2,500 | 1.2 | 27 | 0.6 | 0.4 | 0.3 |
| 3,000 | 1.0 | 39 | 0.4 | 0.3 | 0.2 |
| 3,500 | 0.8 | 54 | 0.3 | 0.2 | 0.1 |

P4000 - COLUMN LOADING (METRIC)

| Unbraced Height mm | Maximum Al- lowable Load at Slot Face kN | Maximum Column Load Applied at C.G. | | | |
|--------------------------|---|-------------------------------------|----------------|---------------|---------------|
| | | K = 0.65 kN | K = 0.80 kN | K = 1.0 kN | K = 1.2 kN |
| 600 | 7.2 | 20.9 | 19.2 | 17.0 | 14.9 |
| 750 | 6.9 | 19.1 | 17.0 | 14.4 | 11.3 |
| 1,000 | 6.1 | 16.1 | 13.3 | 9.2 | 6.5 |
| 1,250 | 5.0 | 13.0 | 9.2 | 5.9 | 4.1 |
| 1,500 | 4.0 | 9.7 | 6.5 | 4.1 | ** |
| 1,750 | 3.2 | 7.2 | 4.7 | ** | ** |

P4001 - COLUMN LOADING (METRIC)

| Unbraced Height mm | Maximum Allowable Load at Slot Face kN | Maximum Column Load Applied at C.G. | | | |
|--------------------------|--|-------------------------------------|----------------|---------------|---------------|
| | | K = 0.65 kN | K = 0.80 kN | K = 1.0 kN | K = 1.2 kN |
| 600 | 12.6 | 46.3 | 44.6 | 42.3 | 40.0 |
| 750 | 12.4 | 44.5 | 42.3 | 39.5 | 35.4 |
| 1,000 | 12.1 | 41.3 | 38.2 | 32.6 | 26.9 |
| 1,250 | 11.4 | 37.8 | 32.6 | 25.4 | 18.8 |
| 1,500 | 10.5 | 33.3 | 26.9 | 18.8 | 13.0 |
| 1,750 | 9.4 | 28.6 | 21.3 | 13.8 | 9.6 |
| 2,000 | 8.1 | 24.1 | 16.5 | 10.5 | ** |
| 2,250 | 7.1 | 19.8 | 13.0 | 8.4 | ** |
| 2,500 | 6.2 | 16.0 | 10.5 | ** | ** |
| 2,750 | 5.4 | 13.2 | 8.7 | ** | ** |

P4000/P4001 - ELEMENTS OF SECTION (METRIC)

| Parameter | P4000 | | P4001 | |
|------------------------|-------|-----------------|-------|-----------------|
| Area of Section | 1.57 | cm ² | 3.14 | cm ² |
| Axis 1-1 | | | | |
| Moment of Inertia (I) | 0.95 | cm ⁴ | 4.32 | cm ⁴ |
| Section Modulus (S) | 0.80 | cm ³ | 2.09 | cm ³ |
| Radius of Gyration (r) | 0.78 | cm | 1.17 | cm |
| Axis 2-2 | | | | |
| Moment of Inertia (I) | 3.81 | cm ⁴ | 7.62 | cm ⁴ |
| Section Modulus (S) | 1.85 | cm ³ | 3.69 | cm ³ |
| Radius of Gyration (r) | 1.56 | cm | 1.56 | cm |

Notes:

* Load limited by spot weld shear.

** $KL_r > 200$

- Above loads include the weight of the member. This weight must be deducted to arrive at the net allowable load the beam will support.
- Long span beams should be supported in such a manner as to prevent rotation and twist.
- Allowable uniformly distributed loads are listed for various simple spans, that is, a beam on two supports. If load is concentrated at the center of the span, multiply load from the table by 0.5 and corresponding deflection by 0.8.
- See page 56 for lateral bracing reduction charts.
- For Pierced Channel, Reduce Beam Load Values as Follows:

"T" Series ... 85% "SL" Series... 85%

"HS" Series ... 90%

1 5/8" Channel
 Telestrut System
 Nuts & Hardware
 General Fittings
 Pipe/Conduit Supports
 Electrical Fittings
 Concrete Inserts
 1 1/4" Framing System
 1 3/8" Framing System
 Fiberglass System
 Special Metals
 PrimeAngle System
 Product Index

P4100

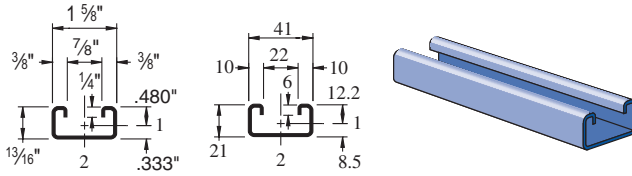

Wt/100 Ft: 98 Lbs (147 kg/100 m)
 Allowable Moment 1,360 In-Lbs (150 N•m)
 14 Gauge Nominal Thickness .075" (1.9mm)

P4101

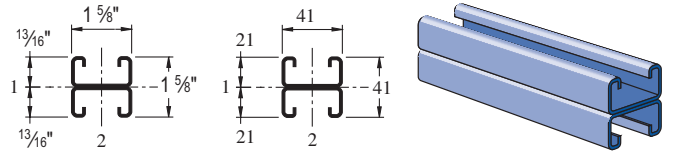

Wt/100 Ft: 197 Lbs (293 kg/100 m)
 Allowable Moment 3,610 In-Lbs (410 N•m)
 14 Gauge Nominal Thickness .075" (1.9mm)

P4100 HS

3/16" (14) Dia. Holes
 1 7/8" (48) on Center

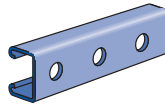

Wt/100 Ft: 87 Lbs (129 kg/100 m)

P4100 T

Slots are
 1 1/8" (29) x 3/16" (14)
 2" (51) on Center

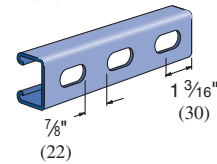

Wt/100 Ft: 87 Lbs (129 kg/100 m)

P4100 SL

Slots are
 3" (76) x 1 3/32" (10.3)
 4" (102) on Center

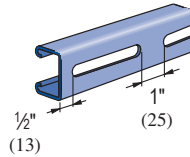

Wt/100 Ft: 87 Lbs (129 kg/100 m)

P4101 T

Slots are
 1 1/8" (29) x 3/16" (14)
 2" (51) on Center

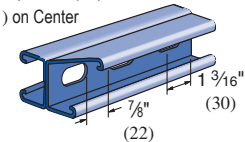

Wt/100 Ft: 174 Lbs (259 kg/100 m)

CHANNEL NUTS (REFER TO HARDWARE SECTION FOR DETAILS)



P4006-0832
 P4006-1024
 P4006-1420
 P4007
 P4008
 P4009
 P4010



P4006T1420
 P4008T
 P4010T



P4012S
 P4023S



P4012
 P4023



P3006-0832
 P3006-1024
 P3006-1420
 P3007
 P3008
 P3009
 P3013



P3016-0632
 P3016-0832
 P3016-1024
 P3016-1420

Channel Finishes: PL, GR, HG, PG; Standard Lengths: 10' & 20'



P4100 - BEAM LOADING

| Span In | Max Allowable Uniform Load Lbs | Defl. at Uniform Load In | Uniform Loading at Deflection | | |
|---------|--------------------------------|--------------------------|-------------------------------|--------------|--------------|
| | | | Span/180 Lbs | Span/240 Lbs | Span/360 Lbs |
| 24 | 450 | 0.11 | 450 | 420 | 280 |
| 36 | 300 | 0.24 | 250 | 190 | 130 |
| 48 | 230 | 0.44 | 140 | 110 | 70 |
| 60 | 180 | 0.67 | 90 | 70 | 50 |
| 72 | 150 | 0.96 | 60 | 50 | 30 |
| 84 | 130 | 1.32 | 50 | 30 | 20 |
| 96 | 110 | 1.67 | 40 | 30 | 20 |
| 108 | 100 | 2.16 | 30 | 20 | 10 |
| 120 | 90 | 2.67 | 20 | 20 | 10 |
| 144 | 80 | 4.09 | 20 | NR | NR |
| 168 | 60 | 4.88 | NR | NR | NR |
| 192 | 60 | 7.28 | NR | NR | NR |
| 216 | 50 | 8.64 | NR | NR | NR |
| 240 | 50 | 11.85 | 11.85 | NR | NR |

P4101 - BEAM LOADING

| Span In | Max Allowable Uniform Load Lbs | Defl. at Uniform Load In | Uniform Loading at Deflection | | |
|---------|--------------------------------|--------------------------|-------------------------------|--------------|--------------|
| | | | Span/180 Lbs | Span/240 Lbs | Span/360 Lbs |
| 24 | 1,090* | 0.06 | 1,090* | 1,090* | 1,090* |
| 36 | 800 | 0.14 | 800 | 800 | 570 |
| 48 | 600 | 0.25 | 600 | 480 | 320 |
| 60 | 480 | 0.39 | 410 | 310 | 200 |
| 72 | 400 | 0.57 | 280 | 210 | 140 |
| 84 | 340 | 0.76 | 210 | 160 | 100 |
| 96 | 300 | 1.00 | 160 | 120 | 80 |
| 108 | 270 | 1.29 | 130 | 90 | 60 |
| 120 | 240 | 1.57 | 100 | 80 | 50 |
| 144 | 200 | 2.26 | 70 | 50 | 40 |
| 168 | 170 | 3.05 | 50 | 40 | 30 |
| 192 | 150 | 4.02 | 40 | NR | NR |
| 216 | 130 | 4.96 | NR | NR | NR |
| 240 | 120 | 6.28 | NR | NR | NR |

P4100 - COLUMN LOADING

| Unbraced Height In | Maximum Allowable Load at Slot Face Lbs | Maximum Column Load Applied at C.G. | | | |
|--------------------|---|-------------------------------------|--------------|-------------|-------------|
| | | K = 0.65 Lbs | K = 0.80 Lbs | K = 1.0 Lbs | K = 1.2 Lbs |
| 24 | 1,840 | 5,610 | 5,210 | 4,570 | 3,850 |
| 36 | 1,640 | 4,660 | 3,850 | 2,800 | 1,960 |
| 48 | 1,310 | 3,490 | 2,480 | 1,590 | 1,100 |
| 60 | 1,000 | 2,400 | 1,590 | ** | ** |
| 72 | 770 | 1,670 | 1,100 | ** | ** |

P4101 - COLUMN LOADING

| Unbraced Height In | Maximum Allowable Load at Slot Face Lbs | Maximum Column Load Applied at C.G. | | | |
|--------------------|---|-------------------------------------|--------------|-------------|-------------|
| | | K = 0.65 Lbs | K = 0.80 Lbs | K = 1.0 Lbs | K = 1.2 Lbs |
| 24 | 3,240 | 12,370 | 11,950 | 11,370 | 10,540 |
| 36 | 3,120 | 11,470 | 10,540 | 9,160 | 7,720 |
| 48 | 2,940 | 10,090 | 8,680 | 6,770 | 4,980 |
| 60 | 2,680 | 8,560 | 6,770 | 4,590 | 3,190 |
| 72 | 2,310 | 7,010 | 4,980 | 3,190 | 2,220 |
| 84 | 1,950 | 5,530 | 3,660 | 2,340 | ** |
| 96 | 1,650 | 4,250 | 2,800 | ** | ** |
| 108 | 1,410 | 3,360 | 2,220 | ** | ** |

P4100/P4101 - ELEMENTS OF SECTION

| Parameter | P4100 | | P4101 | |
|------------------------|-------|-----------------|-------|-----------------|
| Area of Section | 0.290 | In ² | 0.579 | In ² |
| Axis 1-1 | | | | |
| Moment of Inertia (I) | 0.026 | In ⁴ | 0.117 | In ⁴ |
| Section Modulus (S) | 0.054 | In ³ | 0.143 | In ³ |
| Radius of Gyration (r) | 0.298 | In | 0.449 | In |
| Axis 2-2 | | | | |
| Moment of Inertia (I) | 0.107 | In ⁴ | 0.214 | In ⁴ |
| Section Modulus (S) | 0.132 | In ³ | 0.264 | In ³ |
| Radius of Gyration (r) | 0.609 | In | 0.608 | In |

Notes:

* Load limited by spot weld shear.

** $KL/r > 200$

- Above loads include the weight of the member. This weight must be deducted to arrive at the net allowable load the beam will support.
- Long span beams should be supported in such a manner as to prevent rotation and twist.
- Allowable uniformly distributed loads are listed for various simple spans, that is, a beam on two supports. If load is concentrated at the center of the span, multiply load from the table by 0.5 and corresponding deflection by 0.8.
- See page 56 for lateral bracing reduction charts.
- For Pierced Channel, Beam Load Values in the tables are multiplied by the following factor:

"T" Series ... 85% "SL" Series... 85%
 "HS" Series ... 90%

1 5/8" Channel
 Teleslur System
 Nuts & Hardware
 General Fittings
 Pipe/Conduit Supports
 Electrical Fittings
 Concrete Inserts
 1 1/4" Framing System
 1 3/16" Framing System
 Fiberglass System
 Special Metals
 PrimeAngle System
 Product Index

P4100 - BEAM LOADING (METRIC)

| Span mm | Max Allowable Uniform Load kN | Defl. at Uniform Load mm | Uniform Loading at Deflection | | |
|------------|--|-----------------------------------|-------------------------------|----------------|----------------|
| | | | Span/180 kN | Span/240 kN | Span/360 kN |
| 600 | 2.0 | 3 | 2.0 | 2.0 | 1.3 |
| 750 | 1.6 | 4 | 1.6 | 1.2 | 0.8 |
| 1,000 | 1.2 | 7 | 0.9 | 0.7 | 0.4 |
| 1,250 | 1.0 | 11 | 0.6 | 0.4 | 0.3 |
| 1,500 | 0.8 | 16 | 0.4 | 0.3 | 0.2 |
| 1,750 | 0.7 | 23 | 0.3 | 0.2 | 0.1 |
| 2,000 | 0.6 | 30 | 0.2 | 0.2 | 0.1 |
| 2,500 | 0.5 | 46 | 0.1 | 0.1 | 0.1 |
| 3,000 | 0.4 | 65 | 0.1 | 0.1 | NR |

P4101 - BEAM LOADING (METRIC)

| Span mm | Max Allowable Uniform Load kN | Defl. at Uniform Load mm | Uniform Loading at Deflection | | |
|------------|--|-----------------------------------|-------------------------------|----------------|----------------|
| | | | Span/180 kN | Span/240 kN | Span/360 kN |
| 600 | 4.8 * | 1 | 4.8 * | 4.8 * | 4.8 * |
| 750 | 4.4 | 2 | 4.4 | 4.4 | 3.7 |
| 1,000 | 3.2 | 4 | 3.2 | 3.2 | 2.1 |
| 1,250 | 2.6 | 7 | 2.6 | 2.0 | 1.3 |
| 1,500 | 2.2 | 10 | 1.9 | 1.4 | 0.9 |
| 1,750 | 1.9 | 13 | 1.4 | 1.0 | 0.7 |
| 2,000 | 1.6 | 17 | 1.1 | 0.8 | 0.5 |
| 2,500 | 1.3 | 27 | 0.7 | 0.5 | 0.4 |
| 3,000 | 1.1 | 38 | 0.5 | 0.4 | 0.2 |
| 3,500 | 0.9 | 53 | 0.4 | 0.3 | 0.2 |

P4100 - COLUMN LOADING (METRIC)

| Unbraced Height mm | Maximum Allowable Load at Slot Face kN | Maximum Column Load Applied at C.G. | | | |
|--------------------------|--|-------------------------------------|----------------|---------------|---------------|
| | | K = 0.65 kN | K = 0.80 kN | K = 1.0 kN | K = 1.2 kN |
| 600 | 8.2 | 25.1 | 23.3 | 20.6 | 17.4 |
| 750 | 7.8 | 23.2 | 20.6 | 16.6 | 12.8 |
| 1,000 | 6.9 | 19.3 | 15.3 | 10.5 | 7.3 |
| 1,250 | 5.6 | 15.0 | 10.5 | 6.7 | 4.7 |
| 1,500 | 4.5 | 11.0 | 7.3 | 4.7 | ** |
| 1,750 | 3.6 | 8.1 | 5.3 | ** | ** |

P4101 - COLUMN LOADING (METRIC)

| Unbraced Height mm | Maximum Allowable Load at Slot Face kN | Maximum Column Load Applied at C.G. | | | |
|--------------------------|--|-------------------------------------|----------------|---------------|---------------|
| | | K = 0.65 kN | K = 0.80 kN | K = 1.0 kN | K = 1.2 kN |
| 600 | 14.4 | 55.1 | 53.3 | 50.8 | 47.2 |
| 750 | 14.2 | 53.2 | 50.8 | 46.3 | 41.2 |
| 1,000 | 13.7 | 49.4 | 44.7 | 37.8 | 30.8 |
| 1,250 | 13.0 | 44.2 | 37.8 | 29.1 | 21.1 |
| 1,500 | 12.0 | 38.7 | 30.8 | 21.1 | 14.6 |
| 1,750 | 10.7 | 33.0 | 24.2 | 15.5 | 10.8 |
| 2,000 | 9.3 | 27.4 | 18.5 | 11.9 | ** |
| 2,250 | 8.1 | 22.2 | 14.6 | 9.4 | ** |

P4100/P4101 - ELEMENTS OF SECTION (METRIC)

| Parameter | P4100 | P4101 |
|------------------------|----------------------|----------------------|
| Area of Section | 1.87 cm ² | 3.74 cm ² |
| Axis 1-1 | | |
| Moment of Inertia (I) | 1.07 cm ⁴ | 4.85 cm ⁴ |
| Section Modulus (S) | 0.88 cm ³ | 2.35 cm ³ |
| Radius of Gyration (r) | 0.76 cm | 1.14 cm |
| Axis 2-2 | | |
| Moment of Inertia (I) | 4.46 cm ⁴ | 8.93 cm ⁴ |
| Section Modulus (S) | 2.16 cm ³ | 4.32 cm ³ |
| Radius of Gyration (r) | 1.55 cm | 1.55 cm |

Notes:

* Load limited by spot weld shear.

** $KL_i > 200$

- Above loads include the weight of the member. This weight must be deducted to arrive at the net allowable load the beam will support.
- Long span beams should be supported in such a manner as to prevent rotation and twist.
- Allowable uniformly distributed loads are listed for various simple spans, that is, a beam on two supports. If load is concentrated at the center of the span, multiply load from the table by 0.5 and corresponding deflection by 0.8.
- See page 56 for lateral bracing reduction charts.
- For Pierced Channel, Beam Load Values in the tables are multiplied by the following factor:

"T" Series ... 85% "SL" Series... 85%
 "HS" Series ... 90%



P5000

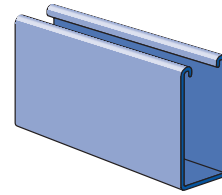
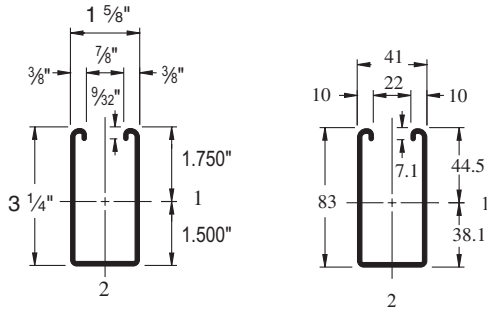

Wt/100 Ft: 305 Lbs (454 kg/100 m)
 Allowable Moment 15,770 In-Lbs (1,780 N•m)
 12 Gauge Nominal Thickness .105" (2.7mm)

P5001

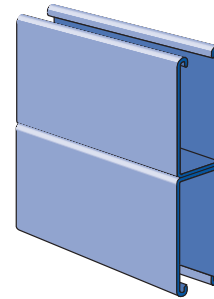
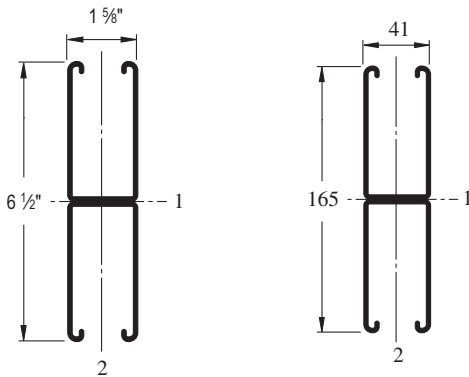

Wt/100 Ft: 610 Lbs (907 kg/100 m)
 Allowable Moment 48,180 In-Lbs (5,440 N•m)
 12 Gauge Nominal Thickness .105" (2.7mm)

P5000 HS

9/16" (14) Dia. Holes
 1 7/8" (48) on Center

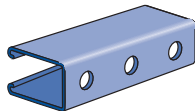

Wt/100 Ft: 300 Lbs (446 kg/100 m)

P5000 KO

7/8" (22) Knockouts
 6" (152) on Center

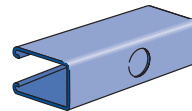

Wt/100 Ft: 305 Lbs (454 kg/100 m)

P5000 SL

Slots are
 3" (76) x 1 3/32" (10.3)
 4" (102) on Center

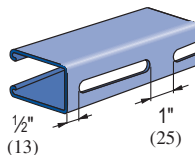

Wt/100 Ft: 300 Lbs (446 kg/100 m)

P5000 T

Slots are
 1 1/8" (29) x 9/16" (14)
 2" (51) on Center

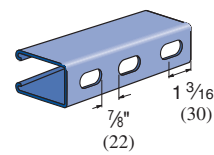

Wt/100 Ft: 300 Lbs (446 kg/100 m)

CHANNEL NUTS (REFER TO HARDWARE SECTION FOR DETAILS)



P1006T1420
P1008T
P1010T



P1012
P1023
P1024



P3006-0832
P3006-1024
P3006-1420
P3007
P3008
P3009
P3010



P3016-0632
P3016-0832
P3016-1024
P3016-1420

Channel Finishes: PL, GR, HG, PG; Standard Lengths: 10' & 20'

1 5/8" Channel
 Telestrut System
 Nuts & Hardware
 General Fittings
 Pipe/Conduit Supports
 Electrical Fittings
 Concrete Inserts
 1 1/4" Framing System
 1 3/16" Framing System
 Fiberglass System
 Special Metals
 PrimeAngle System
 Product Index

P5000 - BEAM LOADING

| Span In | Max Allowable Uniform Load Lbs | Defl. at Uniform Load In | Uniform Loading at Deflection | | |
|---------|--------------------------------|--------------------------|-------------------------------|--------------|--------------|
| | | | Span/180 Lbs | Span/240 Lbs | Span/360 Lbs |
| 24 | 5,260 | 0.03 | 5,260 | 5,260 | 5,260 |
| 36 | 3,500 | 0.07 | 3,500 | 3,500 | 3,500 |
| 48 | 2,630 | 0.12 | 2,630 | 2,630 | 2,630 |
| 60 | 2,100 | 0.18 | 2,100 | 2,100 | 1,920 |
| 72 | 1,750 | 0.26 | 1,750 | 1,750 | 1,330 |
| 84 | 1,500 | 0.36 | 1,500 | 1,470 | 980 |
| 96 | 1,310 | 0.47 | 1,310 | 1,120 | 750 |
| 108 | 1,170 | 0.59 | 1,170 | 890 | 590 |
| 120 | 1,050 | 0.73 | 960 | 720 | 480 |
| 144 | 880 | 1.06 | 670 | 500 | 330 |
| 168 | 750 | 1.43 | 490 | 370 | 240 |
| 192 | 660 | 1.88 | 370 | 280 | 190 |
| 216 | 580 | 2.35 | 300 | 220 | 150 |
| 240 | 530 | 2.95 | 240 | 180 | 120 |

P5001 - BEAM LOADING

| Max Span In | Defl. at Allowable Uniform Load Lbs | Uniform Load In | Uniform Loading at Deflection | | |
|-------------|-------------------------------------|-----------------|-------------------------------|--------------|--------------|
| | | | Span/180 Lbs | Span/240 Lbs | Span/360 Lbs |
| 24 | 6,890* | 0.01 | 6,890* | 6,890* | 6,890* |
| 36 | 6,890* | 0.02 | 6,890* | 6,890* | 6,890* |
| 48 | 6,890* | 0.05 | 6,890* | 6,890* | 6,890* |
| 60 | 6,420 | 0.10 | 6,420 | 6,420 | 6,420 |
| 72 | 5,350 | 0.14 | 5,350 | 5,350 | 5,350 |
| 84 | 4,590 | 0.19 | 4,590 | 4,590 | 4,590 |
| 96 | 4,020 | 0.25 | 4,020 | 4,020 | 4,020 |
| 108 | 3,570 | 0.32 | 3,570 | 3,570 | 3,360 |
| 120 | 3,210 | 0.39 | 3,210 | 3,210 | 2,720 |
| 144 | 2,680 | 0.57 | 2,680 | 2,680 | 1,890 |
| 168 | 2,290 | 0.77 | 2,290 | 2,080 | 1,390 |
| 192 | 2,010 | 1.01 | 2,010 | 1,590 | 1,060 |
| 216 | 1,780 | 1.27 | 1,680 | 1,260 | 840 |
| 240 | 1,610 | 1.58 | 1,360 | 1,020 | 680 |

P5000 - COLUMN LOADING

| Unbraced Height In | Maximum Allowable Load at Slot Face Lbs | Maximum Column Load Applied at C.G. | | | |
|--------------------|---|-------------------------------------|--------------|-------------|-------------|
| | | K = 0.65 Lbs | K = 0.80 Lbs | K = 1.0 Lbs | K = 1.2 Lbs |
| 24 | 5,650 | 16,870 | 15,180 | 12,850 | 10,600 |
| 36 | 4,690 | 13,140 | 10,600 | 7,650 | 5,660 |
| 48 | 3,560 | 9,550 | 6,860 | 4,790 | 3,660 |
| 60 | 2,730 | 6,680 | 4,790 | 3,450 | 2,710 |
| 72 | 2,160 | 4,980 | 3,660 | 2,710 | 2,170 |
| 84 | 1,760 | 3,950 | 2,960 | 2,240 | 1,820 |
| 96 | 1,500 | 3,270 | 2,500 | 1,930 | 1,580 |
| 108 | 1,310 | 2,800 | 2,170 | 1,690 | 1,390 |
| 120 | 1,170 | 2,450 | 1,930 | 1,510 | ** |
| 144 | 980 | 1,980 | 1,580 | ** | ** |
| 168 | 850 | 1,670 | 1,340 | ** | ** |

P5001 - COLUMN LOADING

| Unbraced Height In | Maximum Allowable Load at Slot Face Lbs | Maximum Column Load Applied at C.G. | | | |
|--------------------|---|-------------------------------------|--------------|-------------|-------------|
| | | K = 0.65 Lbs | K = 0.80 Lbs | K = 1.0 Lbs | K = 1.2 Lbs |
| 24 | 10,670 | 39,230 | 38,030 | 36,210 | 34,240 |
| 36 | 10,350 | 36,450 | 34,240 | 31,200 | 28,260 |
| 48 | 9,940 | 33,220 | 30,200 | 26,430 | 23,190 |
| 60 | 9,290 | 29,950 | 26,430 | 22,470 | 19,380 |
| 72 | 8,560 | 26,880 | 23,190 | 19,380 | 16,450 |
| 84 | 7,860 | 24,140 | 20,520 | 17,040 | 12,090 |
| 96 | 7,220 | 21,790 | 18,370 | 13,330 | 9,250 |
| 108 | 6,600 | 19,790 | 16,450 | 10,530 | 7,310 |
| 120 | 5,760 | 18,130 | 13,330 | 8,530 | ** |
| 144 | 4,390 | 14,020 | 9,250 | ** | ** |
| 168 | 3,420 | 10,300 | 6,800 | ** | ** |

P5000/P5001 - ELEMENTS OF SECTION

| Parameter | P5000 | | P5001 | |
|------------------------|-------|-----------------|-------|-----------------|
| Area of Section | 0.897 | In ² | 1.793 | In ² |
| Axis 1-1 | | | | |
| Moment of Inertia (I) | 1.098 | In ⁴ | 6.227 | In ⁴ |
| Section Modulus (S) | 0.627 | In ³ | 1.916 | In ³ |
| Radius of Gyration (r) | 1.107 | In | 1.864 | In |
| Axis 2-2 | | | | |
| Moment of Inertia (I) | 0.433 | In ⁴ | 0.866 | In ⁴ |
| Section Modulus (S) | 0.533 | In ³ | 1.066 | In ³ |
| Radius of Gyration (r) | 0.695 | In | 0.695 | In |

Notes:

* Load limited by spot weld shear.

** $KL_i > 200$

- Above loads include the weight of the member. This weight must be deducted to arrive at the net allowable load the beam will support.
- Long span beams should be supported in such a manner as to prevent rotation and twist.
- Allowable uniformly distributed loads are listed for various simple spans, that is, a beam on two supports. If load is concentrated at the center of the span, multiply load from the table by 0.5 and corresponding deflection by 0.8.
- See page 56 for lateral bracing reduction charts.
- For Pierced Channel, Beam Load Values in the tables are multiplied by the following factor:

"T" Series ... 85% "KO" Series... 95%
 "SL" Series ... 85% "HS" Series... 90%



P5000 - BEAM LOADING (METRIC)

| Span mm | Max Allowable Uniform Load kN | Defl. at Uniform Load mm | Uniform Loading at Deflection | | |
|------------|--|-----------------------------------|-------------------------------|----------------|----------------|
| | | | Span/180 kN | Span/240 kN | Span/360 kN |
| 600 | 23.8 | 1 | 23.8 | 23.8 | 23.8 |
| 750 | 19.0 | 1 | 19.0 | 19.0 | 19.0 |
| 1,000 | 14.2 | 2 | 14.2 | 14.2 | 14.2 |
| 1,250 | 11.4 | 3 | 11.4 | 11.4 | 11.4 |
| 1,500 | 9.5 | 5 | 9.5 | 9.5 | 8.8 |
| 1,750 | 8.1 | 6 | 8.1 | 8.1 | 6.5 |
| 2,000 | 7.1 | 8 | 7.1 | 7.1 | 4.9 |
| 2,500 | 5.7 | 12 | 5.7 | 4.8 | 3.2 |
| 3,000 | 4.8 | 18 | 4.4 | 3.3 | 2.2 |
| 3,500 | 4.1 | 25 | 3.2 | 2.4 | 1.6 |
| 4,000 | 3.6 | 32 | 2.5 | 1.9 | 1.2 |
| 4,500 | 3.2 | 40 | 2.0 | 1.5 | 1.0 |
| 5,000 | 2.8 | 50 | 1.6 | 1.2 | 0.8 |
| 6,000 | 2.4 | 71 | 1.1 | 0.8 | 0.5 |

P5001 - BEAM LOADING (METRIC)

| Span mm | Max Allowable Uniform Load kN | Defl. at Uniform Load mm | Uniform Loading at Deflection | | |
|------------|--|-----------------------------------|-------------------------------|----------------|----------------|
| | | | Span/180 kN | Span/240 kN | Span/360 kN |
| 600 | 30.6 * | 0 | 30.6 * | 30.6 * | 30.6 * |
| 750 | 30.6 * | 0 | 30.6 * | 30.6 * | 30.6 * |
| 1,000 | 30.6 * | 1 | 30.6 * | 30.6 * | 30.6 * |
| 1,250 | 30.6 * | 1 | 30.6 * | 30.6 * | 30.6 * |
| 1,500 | 29.0 | 2 | 29.0 | 29.0 | 29.0 |
| 1,750 | 24.9 | 3 | 24.9 | 24.9 | 24.9 |
| 2,000 | 21.8 | 4 | 21.8 | 21.8 | 21.8 |
| 2,500 | 17.4 | 7 | 17.4 | 17.4 | 17.4 |
| 3,000 | 14.5 | 10 | 14.5 | 14.5 | 12.5 |
| 3,500 | 12.5 | 13 | 12.5 | 12.5 | 9.2 |
| 4,000 | 10.9 | 17 | 10.9 | 10.5 | 7.0 |
| 4,500 | 9.7 | 22 | 9.7 | 8.3 | 5.6 |
| 5,000 | 8.7 | 27 | 8.7 | 6.8 | 4.5 |
| 6,000 | 7.2 | 39 | 6.2 | 4.7 | 3.1 |

P5000 - COLUMN LOADING (METRIC)

| Unbraced Height mm | Maximum Allowable Load at Slot Face kN | Maximum Column Load Applied at C.G. | | | |
|--------------------------|--|-------------------------------------|----------------|---------------|---------------|
| | | K = 0.65 kN | K = 0.80 kN | K = 1.0 kN | K = 1.2 kN |
| 600 | 25.2 | 75.5 | 68.1 | 58.0 | 48.0 |
| 750 | 23.5 | 67.5 | 58.0 | 45.7 | 35.0 |
| 1,000 | 19.4 | 53.7 | 41.9 | 29.3 | 21.8 |
| 1,250 | 15.4 | 41.0 | 29.3 | 20.5 | 15.7 |
| 1,500 | 12.4 | 30.5 | 21.8 | 15.7 | 12.3 |
| 1,750 | 10.2 | 23.8 | 17.3 | 12.8 | 10.2 |
| 2,000 | 8.5 | 19.3 | 14.4 | 10.8 | 8.7 |
| 2,250 | 7.3 | 16.3 | 12.3 | 9.4 | 7.6 |
| 2,500 | 6.5 | 14.1 | 10.8 | 8.3 | 6.9 |
| 2,750 | 5.8 | 12.4 | 9.6 | 7.5 | 6.2 |

P5001 - COLUMN LOADING (METRIC)

| Unbraced Height mm | Maximum Allowable Load at Slot Face kN | Maximum Column Load Applied at C.G. | | | |
|--------------------------|--|-------------------------------------|----------------|---------------|---------------|
| | | K = 0.65 kN | K = 0.80 kN | K = 1.0 kN | K = 1.2 kN |
| 600 | 47.5 | 174.9 | 169.7 | 161.7 | 153.2 |
| 750 | 46.8 | 169.2 | 161.7 | 150.9 | 139.8 |
| 1,000 | 45.6 | 158.2 | 147.2 | 132.6 | 118.8 |
| 1,250 | 44.0 | 146.3 | 132.6 | 115.6 | 101.2 |
| 1,500 | 41.6 | 134.3 | 118.8 | 101.2 | 87.4 |
| 1,750 | 38.9 | 122.9 | 106.6 | 89.4 | 76.8 |
| 2,000 | 36.3 | 112.5 | 96.2 | 80.0 | 61.2 |
| 2,250 | 33.9 | 103.2 | 87.4 | 69.6 | 48.4 |
| 2,500 | 31.6 | 95.0 | 80.0 | 56.4 | 39.1 |
| 2,750 | 29.3 | 87.8 | 72.9 | 46.6 | 32.4 |

P5000/P5001 - ELEMENTS OF SECTION (METRIC)

| Parameter | P5000 | P5001 |
|------------------------|-----------------------|------------------------|
| Area of Section | 5.78 cm ² | 11.57 cm ² |
| Axis 1-1 | | |
| Moment of Inertia (I) | 45.70 cm ⁴ | 259.17 cm ⁴ |
| Section Modulus (S) | 10.28 cm ³ | 31.40 cm ³ |
| Radius of Gyration (r) | 2.81 cm | 4.73 cm |
| Axis 2-2 | | |
| Moment of Inertia (I) | 18.02 cm ⁴ | 36.04 cm ⁴ |
| Section Modulus (S) | 8.73 cm ³ | 17.46 cm ³ |
| Radius of Gyration (r) | 1.77 cm | 1.77 cm |

Notes:

* Load limited by spot weld shear.

** $K_{L}/l > 200$

- Above loads include the weight of the member. This weight must be deducted to arrive at the net allowable load the beam will support.
- Long span beams should be supported in such a manner as to prevent rotation and twist.
- Allowable uniformly distributed loads are listed for various simple spans, that is, a beam on two supports. If load is concentrated at the center of the span, multiply load from the table by 0.5 and corresponding deflection by 0.8.
- See page 56 for lateral bracing reduction charts.
- For Pierced Channel, Beam Load Values in the tables are multiplied by the following factor:

"T" Series ... 85% "KO" Series... 95%
 "SL" Series ... 85% "HS" Series... 90%

1 5/8" Channel
 Telestrut System
 Nuts & Hardware
 General Fittings
 Pipe/Conduit Supports
 Electrical Fittings
 Concrete Inserts
 1 1/4" Framing System
 1 3/8" Framing System
 Fiberglass System
 Special Metals
 PrimeAngle System
 Product Index

P5500

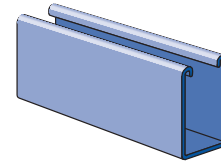
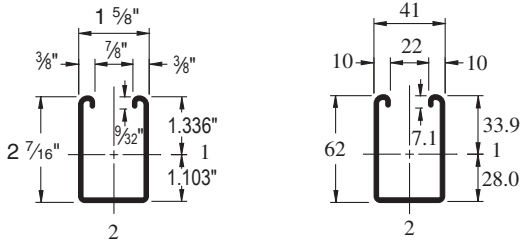

Wt/100 Ft: 247 Lbs (367 kg/100 m)
 Allowable Moment 9,820 In-Lbs (1,110 N•m)
 12 Gauge Nominal Thickness .105" (2.7mm)

P5501

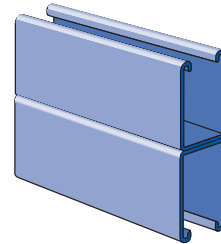
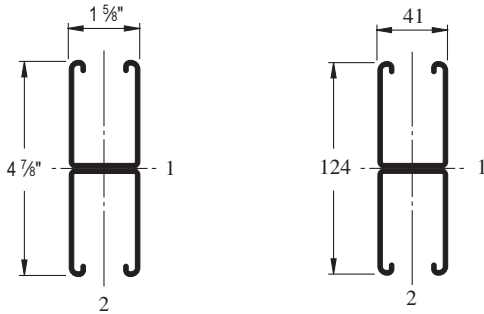

Wt/100 Ft: 494 Lbs (734 kg/100 m)
 Allowable Moment 28,940 In-Lbs (3,270 N•m)
 12 Gauge Nominal Thickness .105" (2.7mm)

P5500 HS

9/16" (14) Dia. Holes
 1 7/8" (48) on Center

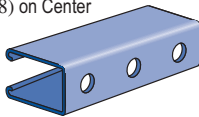

Wt/100 Ft: 242 Lbs (360 kg/100 m)

P5500 KO

7/8" (22) Knockouts
 6" (152) on Center

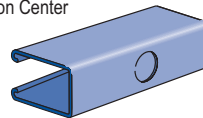

Wt/100 Ft: 247 Lbs (368 kg/100 m)

P5500 SL

Slots are
 3" (76) x 1 3/32" (10.3)
 4" (102) on Center

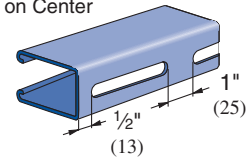

Wt/100 Ft: 242 Lbs (360 kg/100 m)

P5500 T

Slots are
 1 1/8" (29) x 9/16" (14)
 2" (51) on Center

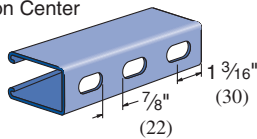

Wt/100 Ft: 242 Lbs (360 kg/100 m)

P5501 T

Slots are
 1 1/8" (29) x 9/16" (14)
 2" (51) on Center

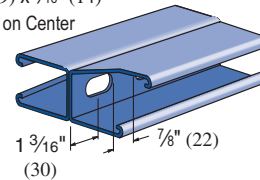

Wt/100 Ft: 494 Lbs (735 kg/100 m)

CHANNEL NUTS (REFER TO HARDWARE SECTION FOR DETAILS)



P5506-0832
 P5506-1024
 P5506-1420
 P5507
 P5508
 P5509
 P5510



P1006T1420
 P1008T
 P1010T



P1012
 P1023
 P1024



P3006-0832
 P3006-1024
 P3006-1420
 P3007
 P3008
 P3009
 P3010



P3016-0632
 P3016-0832
 P3016-1024
 P3016-1420

Channel Finishes: PL, GR, HG, PG; Standard Lengths: 10' & 20'



P5500 - BEAM LOADING

| Span In | Max Allowable Uniform Load Lbs | Defl. at Uniform Load In | Uniform Loading at Deflection | | |
|---------|--------------------------------|--------------------------|-------------------------------|--------------|--------------|
| | | | Span/180 Lbs | Span/240 Lbs | Span/360 Lbs |
| 24 | 3,270 | 0.04 | 3,270 | 3,270 | 3,270 |
| 36 | 2,180 | 0.09 | 2,180 | 2,180 | 2,180 |
| 48 | 1,640 | 0.15 | 1,640 | 1,640 | 1,420 |
| 60 | 1,310 | 0.24 | 1,310 | 1,310 | 910 |
| 72 | 1,090 | 0.34 | 1,090 | 950 | 630 |
| 84 | 940 | 0.47 | 930 | 700 | 470 |
| 96 | 820 | 0.61 | 710 | 530 | 360 |
| 108 | 730 | 0.78 | 560 | 420 | 280 |
| 120 | 650 | 0.95 | 460 | 340 | 230 |
| 144 | 550 | 1.39 | 320 | 240 | 160 |
| 168 | 470 | 1.70 | 189 | 230 | 120 |
| 192 | 410 | 1.30 | 2.46 | 180 | 90 |
| 216 | 360 | 1.10 | 3.07 | 140 | 70 |
| 240 | 330 | 90 | 3.86 | 110 | 60 |

P5501 - BEAM LOADING

| Span In | Max Allowable Uniform Load Lbs | Defl. at Uniform Load In | Uniform Loading at Deflection | | |
|---------|--------------------------------|--------------------------|-------------------------------|--------------|--------------|
| | | | Span/180 Lbs | Span/240 Lbs | Span/360 Lbs |
| 24 | 5,220* | 0.01 | 5,220* | 5,220* | 5,220* |
| 36 | 5,220* | 0.04 | 5,220* | 5,220* | 5,220* |
| 48 | 4,820 | 0.08 | 4,820 | 4,820 | 4,820 |
| 60 | 3,860 | 0.13 | 3,860 | 3,860 | 3,860 |
| 72 | 3,220 | 0.19 | 3,220 | 3,220 | 3,220 |
| 84 | 2,760 | 0.26 | 2,760 | 2,760 | 2,500 |
| 96 | 2,410 | 0.34 | 2,410 | 2,410 | 1,920 |
| 108 | 2,140 | 0.42 | 2,140 | 2,140 | 1,510 |
| 120 | 1,930 | 0.52 | 1,930 | 1,840 | 1,230 |
| 144 | 1,610 | 0.76 | 1,610 | 1,280 | 850 |
| 168 | 1,380 | 1.03 | 1,250 | 940 | 630 |
| 192 | 1,210 | 1.35 | 960 | 720 | 480 |
| 216 | 1,070 | 1.70 | 760 | 570 | 380 |
| 240 | 960 | 2.09 | 610 | 460 | 310 |

P5500 - COLUMN LOADING

| Unbraced Height In | Maximum Allowable Load at Slot Face Lbs | Maximum Column Load Applied at C.G. | | | |
|--------------------|---|-------------------------------------|--------------|-------------|-------------|
| | | K = 0.65 Lbs | K = 0.80 Lbs | K = 1.0 Lbs | K = 1.2 Lbs |
| 24 | 4,640 | 13,840 | 12,570 | 10,840 | 9,190 |
| 36 | 3,970 | 11,050 | 9,190 | 7,030 | 5,370 |
| 48 | 3,180 | 8,420 | 6,390 | 4,620 | 3,630 |
| 60 | 2,550 | 6,250 | 4,620 | 3,450 | 2,780 |
| 72 | 2,120 | 4,790 | 3,630 | 2,780 | 2,260 |
| 84 | 1,810 | 3,890 | 3,010 | 2,330 | 1,910 |
| 96 | 1,580 | 3,290 | 2,580 | 2,020 | 1,650 |
| 108 | 1,400 | 2,860 | 2,260 | 1,770 | 1,440 |
| 120 | 1,270 | 2,530 | 2,020 | 1,580 | ** |
| 144 | 1,060 | 2,070 | 1,650 | ** | ** |
| 168 | 920 | 1,750 | 1,380 | ** | ** |

P5501 - COLUMN LOADING

| Unbraced Height In | Maximum Allowable Load at Slot Face Lbs | Maximum Column Load Applied at C.G. | | | |
|--------------------|---|-------------------------------------|--------------|-------------|-------------|
| | | K = 0.65 Lbs | K = 0.80 Lbs | K = 1.0 Lbs | K = 1.2 Lbs |
| 24 | 8,580 | 31,810 | 30,880 | 29,520 | 28,100 |
| 36 | 8,350 | 29,700 | 28,100 | 26,000 | 24,070 |
| 48 | 8,080 | 27,390 | 25,330 | 22,910 | 20,940 |
| 60 | 7,720 | 25,170 | 22,910 | 20,510 | 17,170 |
| 72 | 7,270 | 23,190 | 20,940 | 17,170 | 12,700 |
| 84 | 6,780 | 21,510 | 18,740 | 13,430 | 9,330 |
| 96 | 6,130 | 20,110 | 15,630 | 10,290 | 7,150 |
| 108 | 5,450 | 17,750 | 12,700 | 8,130 | 5,650 |
| 120 | 4,800 | 15,260 | 10,290 | 6,590 | ** |
| 144 | 3,760 | 10,830 | 7,150 | ** | ** |
| 168 | 2,970 | 7,950 | 5,250 | ** | ** |

P5500/P5501 - ELEMENTS OF SECTION

| Parameter | P5500 | P5501 |
|------------------------|-----------------------|-----------------------|
| Area of Section | 0.726 In ² | 1.452 In ² |
| Axis 1-1 | | |
| Moment of Inertia (I) | 0.522 In ⁴ | 2.805 In ⁴ |
| Section Modulus (S) | 0.390 In ³ | 1.151 In ³ |
| Radius of Gyration (r) | 0.848 In | 1.390 In |
| Axis 2-2 | | |
| Moment of Inertia (I) | 0.334 In ⁴ | 0.669 In ⁴ |
| Section Modulus (S) | 0.411 In ³ | 0.823 In ³ |
| Radius of Gyration (r) | 0.679 In | 0.679 In |

Notes:

* Load limited by spot weld shear.

** $KL/r > 200$

- Above loads include the weight of the member. This weight must be deducted to arrive at the net allowable load the beam will support.
- Long span beams should be supported in such a manner as to prevent rotation and twist.
- Allowable uniformly distributed loads are listed for various simple spans, that is, a beam on two supports. If load is concentrated at the center of the span, multiply load from the table by 0.5 and corresponding deflection by 0.8.
- See page 56 for lateral bracing reduction charts.
- For Pierced Channel, Beam Load Values in the tables are multiplied by the following factor:

"T" Series ... 85% "KO" Series... 95%
 "SL" Series ... 85% "HS" Series... 90%

1 5/8" Channel
 Telestrut System
 Nuts & Hardware
 General Fittings
 Pipe/Conduit Supports
 Electrical Fittings
 Concrete Inserts
 1 1/4" Framing System
 1 3/16" Framing System
 Fiberglass System
 Special Metals
 PrimeAngle System
 Product Index

P5500 - BEAM LOADING (METRIC)

| Span mm | Max Allowable Uniform Load kN | Defl. at Uniform Load mm | Uniform Loading at Deflection | | |
|------------|--|-----------------------------------|-------------------------------|----------------|----------------|
| | | | Span/180 kN | Span/240 kN | Span/360 kN |
| 600 | 14.8 | 1 | 14.8 | 14.8 | 14.8 |
| 750 | 11.8 | 1 | 11.8 | 11.8 | 11.8 |
| 1,000 | 8.9 | 3 | 8.9 | 8.9 | 8.9 |
| 1,250 | 7.1 | 4 | 7.1 | 7.1 | 6.1 |
| 1,500 | 5.9 | 6 | 5.9 | 5.9 | 4.2 |
| 1,750 | 5.1 | 8 | 5.1 | 4.6 | 3.1 |
| 2,000 | 4.5 | 10 | 4.5 | 3.5 | 2.4 |
| 2,500 | 3.6 | 16 | 3.0 | 2.3 | 1.5 |
| 3,000 | 3.0 | 24 | 2.1 | 1.6 | 1.1 |
| 3,500 | 2.5 | 32 | 1.6 | 1.2 | 0.8 |
| 4,000 | 2.2 | 42 | 1.2 | 0.9 | 0.6 |
| 4,500 | 2.0 | 53 | 0.9 | 0.7 | 0.4 |
| 5,000 | 1.8 | 66 | 0.8 | 0.6 | 0.4 |
| 6,000 | 1.5 | 94 | 0.5 | 0.4 | 0.3 |

P5501 - BEAM LOADING (METRIC)

| Span mm | Max Allowable Uniform Load kN | Defl. at Uniform Load mm | Uniform Loading at Deflection | | |
|------------|--|-----------------------------------|-------------------------------|----------------|----------------|
| | | | Span/180 kN | Span/240 kN | Span/360 kN |
| 600 | 23.2 * | 0 | 23.2 * | 23.2 * | 23.2 * |
| 750 | 23.2 * | 1 | 23.2 * | 23.2 * | 23.2 * |
| 1,000 | 23.2 * | 1 | 23.2 * | 23.2 * | 23.2 * |
| 1,250 | 20.9 | 2 | 20.9 | 20.9 | 20.9 |
| 1,500 | 17.4 | 3 | 17.4 | 17.4 | 17.4 |
| 1,750 | 14.9 | 4 | 14.9 | 14.9 | 14.9 |
| 2,000 | 13.1 | 6 | 13.1 | 13.1 | 12.7 |
| 2,500 | 10.5 | 9 | 10.5 | 10.5 | 8.1 |
| 3,000 | 8.7 | 13 | 8.7 | 8.5 | 5.6 |
| 3,500 | 7.5 | 18 | 7.5 | 6.2 | 4.1 |
| 4,000 | 6.5 | 23 | 6.3 | 4.8 | 3.2 |
| 4,500 | 5.8 | 29 | 5.0 | 3.7 | 2.5 |
| 5,000 | 5.2 | 36 | 4.1 | 3.0 | 2.0 |
| 6,000 | 4.4 | 52 | 2.8 | 2.1 | 1.4 |

P5500 - COLUMN LOADING (METRIC)

| Unbraced Height mm | Maximum Allowable Load at Slot Face kN | Maximum Column Load Applied at C.G. | | | |
|--------------------------|--|-------------------------------------|----------------|---------------|---------------|
| | | K = 0.65 kN | K = 0.80 kN | K = 1.0 kN | K = 1.2 kN |
| 600 | 20.7 | 61.9 | 56.4 | 48.8 | 41.6 |
| 750 | 19.6 | 55.9 | 48.8 | 39.8 | 31.9 |
| 1,000 | 16.7 | 45.7 | 37.0 | 27.4 | 21.0 |
| 1,250 | 13.8 | 36.4 | 27.4 | 19.9 | 15.7 |
| 1,500 | 11.5 | 28.5 | 21.0 | 15.7 | 12.6 |
| 1,750 | 9.8 | 22.6 | 17.1 | 13.0 | 10.6 |
| 2,000 | 8.6 | 18.9 | 14.5 | 11.2 | 9.1 |
| 2,250 | 7.6 | 16.2 | 12.6 | 9.8 | 8.0 |
| 2,500 | 6.9 | 14.2 | 11.2 | 8.7 | 7.2 |
| 2,750 | 6.2 | 12.7 | 10.1 | 7.9 | 6.4 |

P5501 - COLUMN LOADING (METRIC)

| Unbraced Height mm | Maximum Allowable Load at Slot Face kN | Maximum Column Load Applied at C.G. | | | |
|--------------------------|--|-------------------------------------|----------------|---------------|---------------|
| | | K = 0.65 kN | K = 0.80 kN | K = 1.0 kN | K = 1.2 kN |
| 600 | 38.2 | 141.5 | 137.4 | 131.3 | 125.0 |
| 750 | 37.1 | 132.1 | 125.0 | 115.6 | 107.1 |
| 1,000 | 35.9 | 121.8 | 112.7 | 101.9 | 93.1 |
| 1,250 | 34.3 | 112.0 | 101.9 | 91.2 | 76.4 |
| 1,500 | 32.3 | 103.2 | 93.1 | 76.4 | 56.5 |
| 1,750 | 30.2 | 95.7 | 83.4 | 59.7 | 41.5 |
| 2,000 | 27.3 | 89.5 | 69.5 | 45.8 | 31.8 |
| 2,500 | 24.2 | 79.0 | 56.5 | 36.2 | 25.1 |
| 3,000 | 21.3 | 67.9 | 45.8 | 29.3 | ** |
| 3,500 | 16.7 | 48.2 | 31.8 | ** | ** |
| 4,000 | 13.2 | 35.4 | 23.3 | ** | ** |

P5500/P5501 - ELEMENTS OF SECTION (METRIC)

| Parameter | P5500 | P5501 |
|------------------------|-----------------------|------------------------|
| Area of Section | 4.68 cm ² | 9.37 cm ² |
| Axis 1-1 | | |
| Moment of Inertia (I) | 21.71 cm ⁴ | 116.76 cm ⁴ |
| Section Modulus (S) | 6.40 cm ³ | 18.86 cm ³ |
| Radius of Gyration (r) | 2.15 cm | 3.53 cm |
| Axis 2-2 | | |
| Moment of Inertia (I) | 13.91 cm ⁴ | 27.83 cm ⁴ |
| Section Modulus (S) | 6.74 cm ³ | 13.48 cm ³ |
| Radius of Gyration (r) | 1.72 cm | 1.72 cm |

Notes:

* Load limited by spot weld shear.

** $KL_r > 200$

- Above loads include the weight of the member. This weight must be deducted to arrive at the net allowable load the beam will support.
- Long span beams should be supported in such a manner as to prevent rotation and twist.
- Allowable uniformly distributed loads are listed for various simple spans, that is, a beam on two supports. If load is concentrated at the center of the span, multiply load from the table by 0.5 and corresponding deflection by 0.8.
- See page 56 for lateral bracing reduction charts.
- For Pierced Channel, Beam Load Values in the tables are multiplied by the following factor:

"T" Series ... 85% "KO" Series... 95%
 "SL" Series ... 85% "HS" Series... 90%



P1184

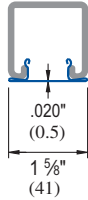
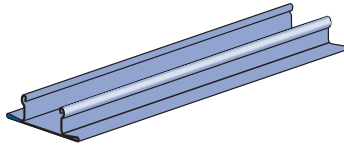

Finish: Pregalvanized, plain.
Standard length: 10' (3m)

Wt/100 Ft: 27 Lbs (40.2 kg/100 m)

P1184 P

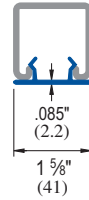
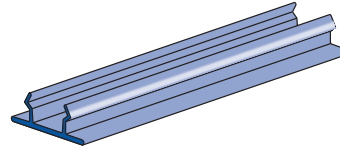

Material: Paintable PVC.
Color: Green, Grey.
Standard length: 10' (3m)

Wt/100 Ft: 11 Lbs (16.5 kg/100 m)

P3184

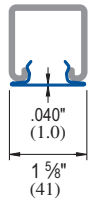
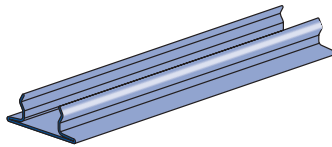

Finish: Green, pre-galvanized, plain.
Standard length: 10' (3m)

Wt/100 Ft: 47 Lbs (69.9 kg/100 m)

P3184 P

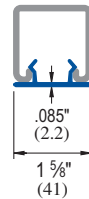
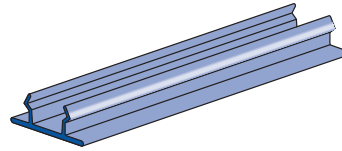

Material : G.E. Noryl® Plastic.
Color: Green, Grey and White.
Standard length: 10' (3m)

Wt/100 Ft: 9.4 Lbs (14.0 kg/100 m)

P3184 F

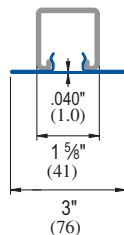
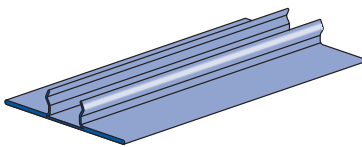

Finish: Green, pre-galvanized, plain.
Standard length: 16' (4.9m)

Wt/100 Ft: 90 Lbs (134 kg/100 m)

P3712 P

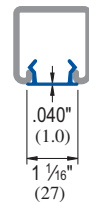
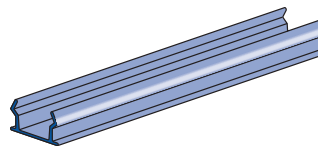

Material: Plastic.
Color: Black.
Standard length: 10' (3m)
Note: Use with P3170, P3270, and P3370 series concrete insert.

Wt/100 Ft: 5.4 Lbs (8.0 kg/100 m)

1 5/8" Channel
Telestrut System
Nuts & Hardware
General Fittings
Pipe/Conduit Supports
Electrical Fittings
Concrete Inserts
1 1/4" Framing System
1 3/16" Framing System
Fiberglass System
Special Metals
PrimeAngle System
Product Index

P2859

FRAME CAPS

P1180, P2280, P4280, P5280, P5580

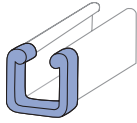

| Part Number* | Use With Channel | Wt/100 pcs Lbs (kg) |
|--------------|------------------|------------------------|
| P2859-10 | P1000 | 12 5.4 |
| P2859-11 | P1001 | 12 5.4 |
| P2859-12 | P3300 | 5 2.3 |
| P2859-13 | P5000 | 22 10.0 |
| P2859-14 | P5500 | 17 7.7 |

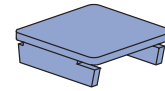

| Part Number | Use With Channel | Wt/100 pcs Lbs (kg) |
|-------------|------------------|------------------------|
| P1180 | P1100 | 12 5.4 |
| P2280 | P2000 | 11 5.0 |
| P4280 | P4000 | 5 2.3 |
| P5280 | P5000 | 22 10.0 |
| P5580 | P5500 | 17 7.7 |

Material: .075" (1.9)

Note:
For P3000 see pages 37, 185,
P3300 see pages 39, 185

* Add color suffix:

GR - Green WH - White GY - Grey
"A" series frame caps available

P1280

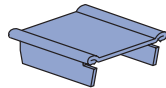

Use with P1000
Material: .060" (1.5)

Wt/100 pcs: 11 Lbs (5.0 Kg.)

P1280 A, P2280 A

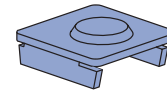

| Part Number | Use With Channel | Wt/100 pcs Lbs (kg) |
|-------------|------------------|------------------------|
| P1280A | P1000 | 11 5.0 |
| P2280A | P2000 | 11 5.0 |

Material: .075" (1.9)

P2860

PLASTIC WHITE END CAPS

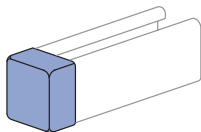

P2860-10

Use with P1000, P1100, P2000 channels & P9000 Telestrut.
Wt/100 pcs 3.4 Lbs (1.5 kg)

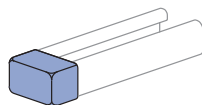

P2860-33

Use with P3300 channel.
Wt/100 pcs 2.5 Lbs (1.1 kg)

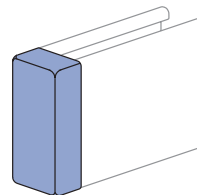

P2860-50

Use with P5000 & P1001 channels.
Wt/100 pcs 5 Lbs (2.3 kg)

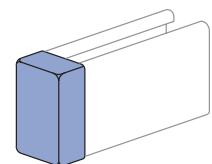

P2860-55

Use with P5500 channel.
Wt/100 pcs 4.7 Lbs (2.1 kg)

LATERAL BRACING LOAD REDUCTION CHARTS

| Span | | Single Channel | | | | | | | | | Double Channel | | | | | | | | |
|-----------|-----------|----------------|-------|-------|-------|-------|-------|-------|-------|-------|----------------|-------|-------|-------|-------|-------|-------|-------|-------|
| Ft. (m) | In. (cm) | P1000 | P1100 | P2000 | P3000 | P3300 | P4000 | P4100 | P5000 | P5500 | P1001 | P1101 | P2001 | P3001 | P3301 | P4001 | P4101 | P5001 | P5501 |
| 2 (0.61) | 24 (61) | 1.00 | 1.00 | 1.00 | 1.00 | 1.00 | 1.00 | 1.00 | 0.98 | 0.99 | 1.00 | 1.00 | 1.00 | 1.00 | 1.00 | 1.00 | 1.00 | 1.00 | 1.00 |
| 3 (0.91) | 36 (91) | 0.94 | 0.89 | 0.88 | 0.96 | 1.00 | 0.94 | 0.98 | 0.85 | 0.89 | 1.00 | 1.00 | 1.00 | 1.00 | 1.00 | 1.00 | 1.00 | 1.00 | 1.00 |
| 4 (1.22) | 48 (122) | 0.88 | 0.78 | 0.75 | 0.91 | 1.00 | 0.88 | 0.94 | 0.70 | 0.77 | 1.00 | 0.98 | 0.98 | 1.00 | 1.00 | 0.98 | 1.00 | 0.97 | 0.98 |
| 5 (1.52) | 60 (152) | 0.82 | 0.68 | 0.61 | 0.88 | 0.98 | 0.83 | 0.91 | 0.55 | 0.67 | 0.97 | 0.93 | 0.92 | 0.98 | 1.00 | 0.93 | 0.96 | 0.90 | 0.93 |
| 6 (1.83) | 72 (183) | 0.78 | 0.59 | 0.48 | 0.84 | 0.97 | 0.79 | 0.89 | 0.44 | 0.58 | 0.93 | 0.87 | 0.85 | 0.95 | 0.97 | 0.88 | 0.92 | 0.83 | 0.87 |
| 7 (2.13) | 84 (213) | 0.75 | 0.52 | 0.41 | 0.82 | 0.96 | 0.75 | 0.86 | 0.38 | 0.51 | 0.89 | 0.82 | 0.78 | 0.92 | 0.95 | 0.83 | 0.89 | 0.76 | 0.81 |
| 8 (2.44) | 96 (244) | 0.71 | 0.47 | 0.35 | 0.79 | 0.94 | 0.72 | 0.84 | 0.33 | 0.46 | 0.85 | 0.76 | 0.71 | 0.88 | 0.92 | 0.79 | 0.85 | 0.68 | 0.76 |
| 9 (2.74) | 108 (274) | 0.69 | 0.43 | 0.32 | 0.77 | 0.93 | 0.69 | 0.82 | 0.30 | 0.42 | 0.81 | 0.70 | 0.64 | 0.85 | 0.90 | 0.74 | 0.81 | 0.61 | 0.70 |
| 10 (3.05) | 120 (305) | 0.66 | 0.40 | 0.29 | 0.75 | 0.92 | 0.66 | 0.80 | 0.28 | 0.40 | 0.78 | 0.65 | 0.57 | 0.82 | 0.87 | 0.69 | 0.78 | 0.54 | 0.64 |
| 12 (3.66) | 144 (366) | 0.61 | 0.36 | 0.25 | 0.70 | 0.89 | 0.60 | 0.76 | 0.24 | 0.36 | 0.70 | 0.54 | 0.45 | 0.76 | 0.82 | 0.60 | 0.71 | 0.43 | 0.53 |
| 14 (4.27) | 168 (427) | 0.55 | 0.32 | 0.23 | 0.66 | 0.86 | 0.55 | 0.73 | 0.22 | 0.32 | 0.63 | 0.45 | 0.38 | 0.70 | 0.78 | 0.51 | 0.64 | 0.35 | 0.45 |
| 16 (4.88) | 192 (488) | 0.51 | 0.30 | 0.21 | 0.62 | 0.84 | 0.50 | 0.69 | 0.21 | 0.30 | 0.56 | 0.39 | 0.32 | 0.64 | 0.73 | 0.44 | 0.57 | 0.30 | 0.39 |
| 18 (5.49) | 216 (549) | 0.47 | 0.28 | 0.19 | 0.58 | 0.81 | 0.47 | 0.65 | 0.19 | 0.28 | 0.49 | 0.34 | 0.28 | 0.58 | 0.68 | 0.39 | 0.50 | 0.27 | 0.34 |
| 20 (6.10) | 240 (610) | 0.44 | 0.26 | 0.18 | 0.54 | 0.78 | 0.43 | 0.61 | 0.18 | 0.26 | 0.44 | 0.31 | 0.25 | 0.52 | 0.63 | 0.35 | 0.45 | 0.24 | 0.30 |

BEARING LOADS ON UNISTRUT CHANNEL

| Channel | Bearing Length 1 5/8" (41 mm) Maximum Allowable Loads Lbs (kN) | | Bearing Length 1 5/8" (41 mm) Maximum Allowable Loads Lbs (kN) | | Bearing Length 3 1/4" (82 mm) Maximum Allowable Loads Lbs (kN) | |
|---------|--|------|--|------|--|------|
| | Lbs | (kN) | Lbs | (kN) | Lbs | (kN) |
| P1000 | 6,700 | 29 | 3,100 | 14 | 7,700 | 92 |
| P1100 | 3,500 | 15 | 1,700 | 7 | 4,000 | 18 |
| P2000 | 2,500 | 11 | 1,200 | 5 | 3,000 | 13 |
| P3000 | 6,700 | 29 | 3,200 | 14 | 7,700 | 34 |
| P3300 | 6,800 | 29 | 3,200 | 14 | 7,800 | 34 |
| P4000 | 2,600 | 9 | 1,200 | 5 | 3,000 | 13 |
| P4100 | 3,500 | 16 | 1,800 | 8 | 4,100 | 18 |
| P5000 | 6,500 | 28 | 3,000 | 13 | 7,500 | 33 |
| P5500 | 6,600 | 29 | 3,100 | 14 | 7,600 | 33 |



TELESTRUT® SYSTEM

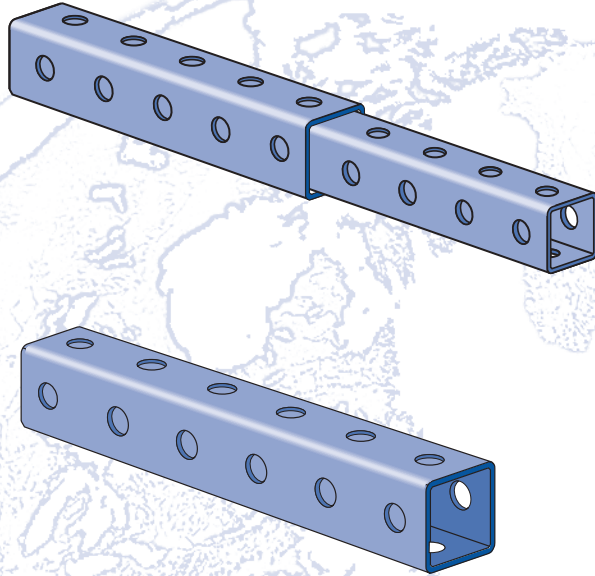

Telescoping Tube.....59-61

Connection Methods 62

Specialized Fittings 62

Post Bases.....62-63

Cutting Chart..... 64

MATERIAL

Unistrut channels are accurately and carefully cold formed to size from low-carbon strip steel.

STEEL: PLAIN

12 Ga. (2.7 mm), 14 Ga.(1.9 mm) and
16 Ga. (1.5 mm) ASTM A1011 SS GR 33.

STEEL: PRE-GALVANIZED

12 Ga. (2.7 mm), 14 Ga. (1.9 mm) and
16 Ga. (1.5mm) ASTM A653 GR 33.

FINISHES

Fittings are available in:

- Perma-Green III (GR),
- Electro-galvanized (EG), conforming to
ASTM B633 Type III SC1;
- Hot-dipped Galvanized (HG), conforming to
ASTM A123 or A153
- Plain (PL).

DIMENSIONS

Imperial dimensions are illustrated in inches. Metric dimensions are shown in parenthesis or as noted. Unless noted, all metric dimensions are in millimeters and rounded to one decimal place.

DESIGN BOLT TORQUE

| BOLT SIZE | ¼"-20 | ⅜"-18 | ½"-16 | ⅝"-13 | ¾"-11 | 1"-10 |
|----------------------------|----------|------------|------------|------------|--------------|--------------|
| Rec.Torque Ft/Lbs (N·m) | 6 (8) | 11 (15) | 19 (26) | 50 (68) | 100 (136) | 125 (170) |
| Max Torque Ft/Lbs (N·m) | 7 (9) | 15 (20) | 25 (34) | 70 (95) | 125 (170) | 135 (183) |

DESIGN LOAD

Load tables and charts are constructed to be in accordance with the SPECIFICATION FOR THE DESIGN OF COLD-FORMED STEEL STRUCTURAL MEMBERS 2001 EDITION published by the AMERICAN IRON AND STEEL INSTITUTE USING ASD METHOD.

| Type of Load | Safety Factor to Yield Strength | Safety Factor to Ultimate Strength |
|--------------|---------------------------------|------------------------------------|
| Beam Loads | 1.67 | 2.0 |
| Column Load | 1.80 | 2.2 |



Telestrut Telescoping Tubing

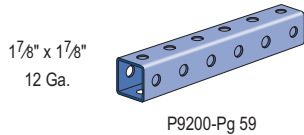
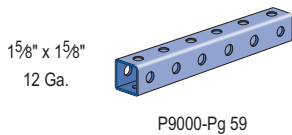

Special Fittings and Connection Hardware for Telestrut Telescoping Tubing

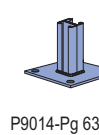
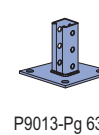
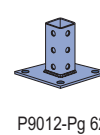
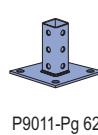
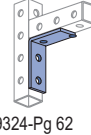

Standard 1 5/8" Metal Framing – Flat Plate Fittings

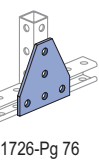
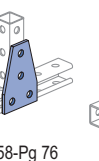
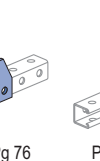
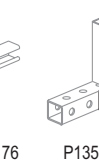
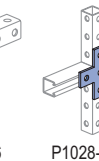
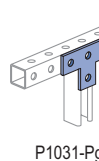
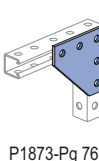
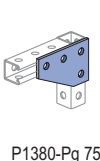
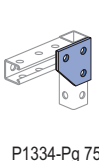
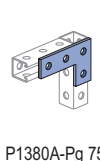
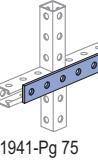
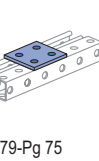
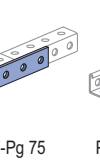
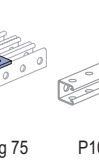
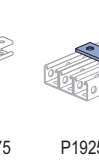
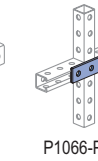
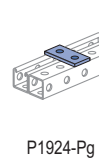
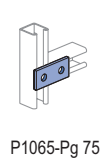
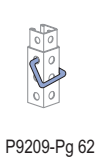

Standard 1 5/8" Metal Framing – Ninety Degree Fittings

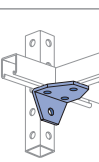
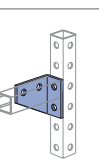
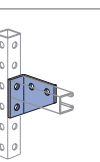
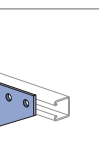
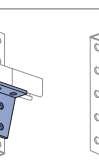
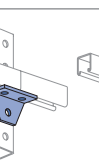
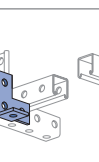
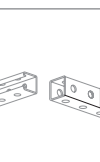
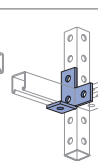
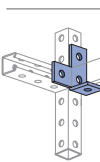
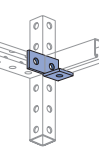
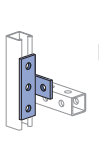
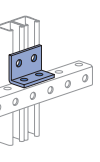
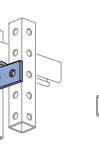
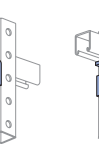
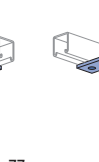
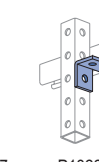
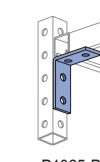
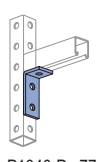
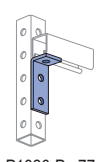
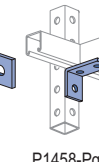
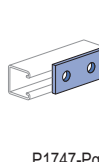
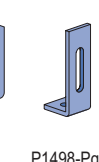
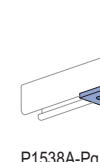
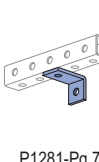
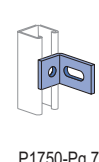
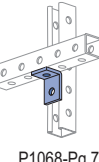
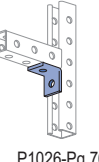
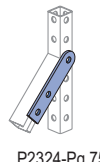
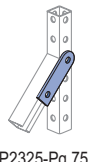
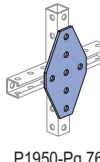

Standard 1 5/8" Metal Framing – "Z" and "U" Shape Fittings

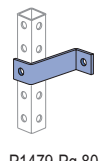
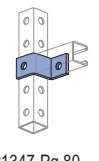
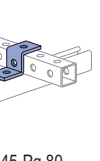
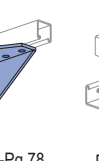
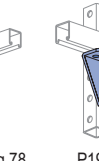
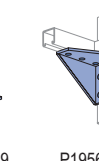
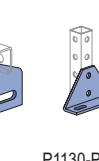
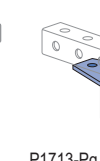
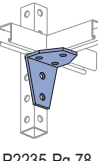
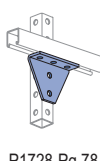

Standard 1 5/8" Metal Framing – Wing Shape Fittings

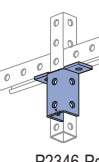
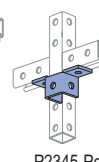
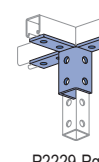
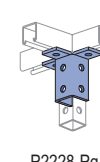
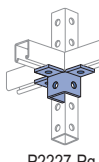
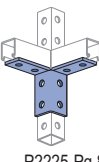
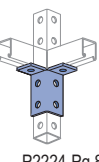
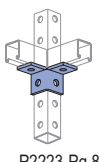
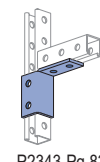
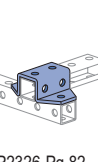
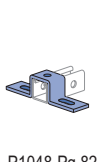

1 5/8" Channel
 Telestrut System
 Nuts & Hardware
 General Fittings
 Pipe/Conduit Supports
 Electrical Fittings
 Concrete Inserts
 1 1/4" Framing System
 1 3/16" Framing System
 Fiberglass System
 Special Metals
 PrimeAngle System
 Product Index

Standard 1 5/8" Metal Framing – Wing Shape Fittings

Standard 1 5/8" Metal Framing – Misc. Fittings

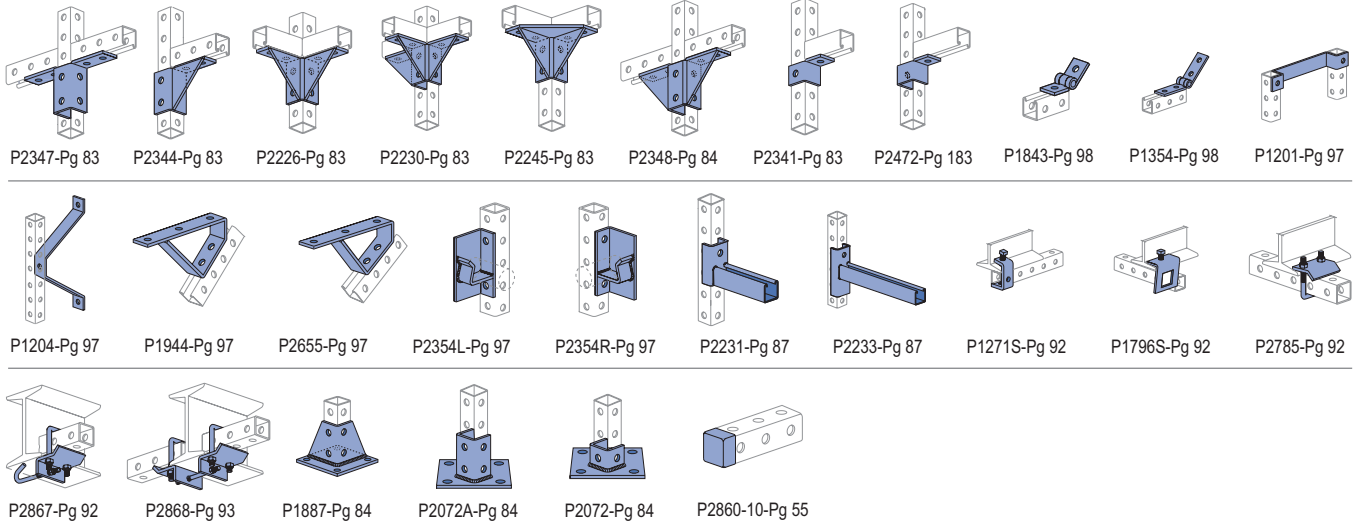

Many of the standard metal framing components are compatible with the Telestrut telescoping tubing. Refer to the appropriate page in other sections of the catalog for information on the particular fittings shown here.

P9000

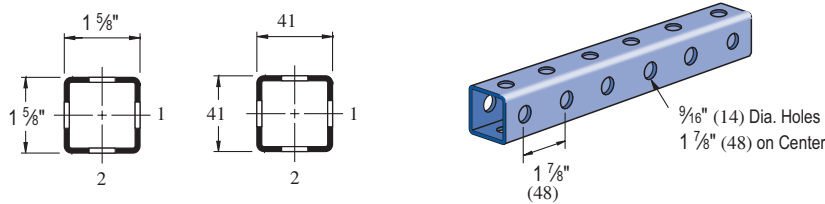

Wt/100 Ft: 188 Lbs (279 kg/100 m)
 Allowable Moment 5,140 In-Lbs (580 N·m)
 12 Gauge Nominal Thickness .105" (2.7mm)

P9200

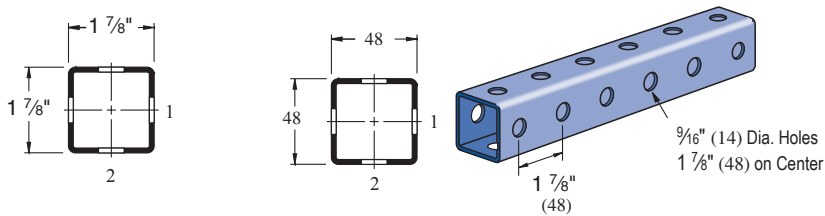

Wt/100 Ft: 223 Lbs (331 kg/100 m)
 Allowable Moment 7,480 In-Lbs (850 N·m)
 12 Gauge Nominal Thickness .105" (2.7mm)

TELESTRUT'S TELESCOPING POWER

Telestrut can be combined with metal framing channel

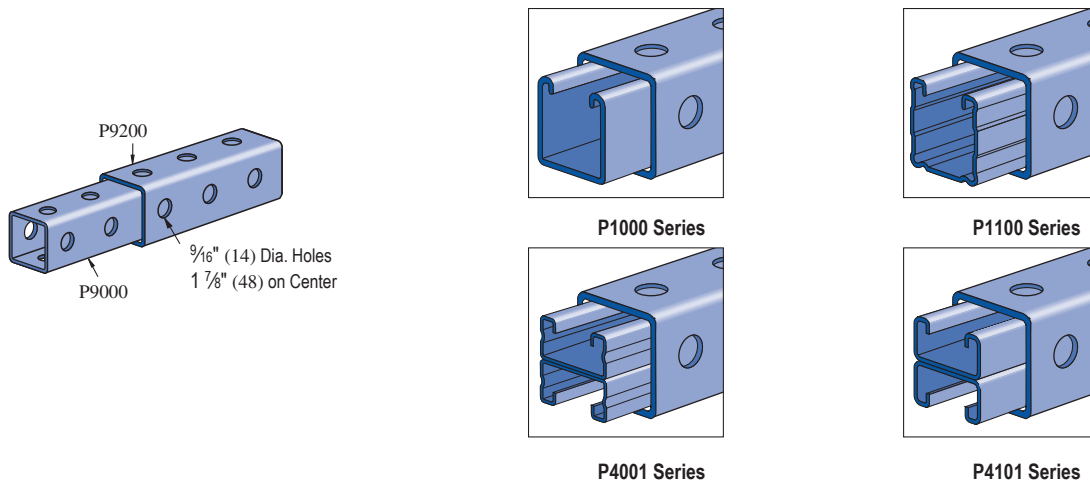



P9000 - BEAM LOADING

| Span In | Max Allowable Uniform Load Lbs | Defl. at Uniform Load In | Uniform Loading at Deflection | | |
|---------|--------------------------------|--------------------------|-------------------------------|--------------|--------------|
| | | | Span/180 Lbs | Span/240 Lbs | Span/360 Lbs |
| 24 | 1,710 | 0.06 | 1,710 | 1,710 | 1,710 |
| 36 | 1,140 | 0.14 | 1,140 | 1,140 | 810 |
| 48 | 860 | 0.25 | 860 | 680 | 450 |
| 60 | 690 | 0.40 | 580 | 440 | 290 |
| 72 | 570 | 0.57 | 400 | 300 | 200 |
| 84 | 490 | 0.77 | 300 | 220 | 150 |
| 96 | 430 | 1.01 | 230 | 170 | 110 |
| 108 | 380 | 1.27 | 180 | 130 | 90 |
| 120 | 340 | 1.56 | 150 | 110 | 70 |
| 144 | 290 | 2.30 | 100 | 80 | 50 |
| 168 | 240 | 3.02 | 70 | 60 | 40 |
| 192 | 210 | 3.95 | 60 | 40 | NR |
| 216 | 190 | 5.09 | 40 | NR | NR |
| 240 | 170 | 6.24 | 40 | NR | NR |

P9200 - BEAM LOADING

| Span In | Max Allowable Uniform Load Lbs | Defl. at Uniform Load In | Uniform Loading at Deflection | | |
|---------|--------------------------------|--------------------------|-------------------------------|--------------|--------------|
| | | | Span/180 Lbs | Span/240 Lbs | Span/360 Lbs |
| 24 | 2,490 | 0.05 | 2,490 | 2,490 | 2,490 |
| 36 | 1,660 | 0.12 | 1,660 | 1,660 | 1,350 |
| 48 | 1,250 | 0.22 | 1,250 | 1,140 | 760 |
| 60 | 1,000 | 0.34 | 980 | 730 | 490 |
| 72 | 830 | 0.49 | 680 | 510 | 340 |
| 84 | 710 | 0.67 | 500 | 370 | 250 |
| 96 | 620 | 0.87 | 380 | 290 | 190 |
| 108 | 550 | 1.10 | 300 | 230 | 150 |
| 120 | 500 | 1.37 | 240 | 180 | 120 |
| 144 | 420 | 1.98 | 170 | 130 | 80 |
| 168 | 360 | 2.70 | 120 | 90 | 60 |
| 192 | 310 | 3.47 | 100 | 70 | 50 |
| 216 | 280 | 4.47 | 80 | 60 | NR |
| 240 | 250 | 5.47 | 60 | 50 | NR |

P9000 - COLUMN LOADING

| Unbraced Height In | Maximum Allowable Load at Slot Face Lbs | Maximum Column Load Applied at C.G. | | | |
|--------------------|---|-------------------------------------|--------------|-------------|-------------|
| | | K = 0.65 Lbs | K = 0.80 Lbs | K = 1.0 Lbs | K = 1.2 Lbs |
| 24 | 3,640 | 8,730 | 8,570 | 8,330 | 8,040 |
| 36 | 3,540 | 8,360 | 8,040 | 7,530 | 6,950 |
| 48 | 3,400 | 7,880 | 7,340 | 6,530 | 5,660 |
| 60 | 3,210 | 7,290 | 6,530 | 5,440 | 4,360 |
| 72 | 2,990 | 6,640 | 5,660 | 4,360 | 3,160 |
| 84 | 2,730 | 5,940 | 4,790 | 3,340 | 2,320 |
| 96 | 2,430 | 5,220 | 3,940 | 2,560 | 1,780 |
| 108 | 2,110 | 4,520 | 3,160 | 2,020 | 1,400 |
| 120 | 1,820 | 3,840 | 2,560 | 1,640 | ** |
| 144 | 1,390 | 2,690 | 1,780 | ** | ** |

P9200 - COLUMN LOADING

| Unbraced Height In | Maximum Allowable Load at Slot Face Lbs | Maximum Column Load Applied at C.G. | | | |
|--------------------|---|-------------------------------------|--------------|-------------|-------------|
| | | K = 0.65 Lbs | K = 0.80 Lbs | K = 1.0 Lbs | K = 1.2 Lbs |
| 24 | 4,620 | 11,120 | 10,980 | 10,740 | 10,460 |
| 36 | 4,530 | 10,770 | 10,460 | 9,950 | 9,370 |
| 48 | 4,390 | 10,300 | 9,760 | 8,940 | 8,030 |
| 60 | 4,220 | 9,720 | 8,940 | 7,800 | 6,590 |
| 72 | 4,000 | 9,050 | 8,030 | 6,590 | 5,180 |
| 84 | 3,750 | 8,320 | 7,080 | 5,410 | 3,890 |
| 96 | 3,460 | 7,560 | 6,110 | 4,290 | 2,980 |
| 108 | 3,140 | 6,770 | 5,180 | 3,390 | 2,360 |
| 120 | 2,790 | 5,990 | 4,290 | 2,750 | 1,910 |
| 144 | 2,170 | 4,510 | 2,980 | 1,910 | ** |
| 168 | 1,720 | 3,320 | 2,190 | ** | ** |

P9000/P9200 - ELEMENTS OF SECTION

| Parameter | P9000 | | P9200 | |
|------------------------|-------|-----------------|-------|-----------------|
| | | | | |
| Area of Section | 0.387 | In ² | 0.489 | In ² |
| Axis 1-1 | | | | |
| Moment of Inertia (I) | 0.166 | In ⁴ | 0.279 | In ⁴ |
| Section Modulus (S) | 0.205 | In ³ | 0.297 | In ³ |
| Radius of Gyration (r) | 0.655 | In | 0.755 | In |
| Axis 2-2 | | | | |
| Moment of Inertia (I) | 0.166 | In ⁴ | 0.279 | In ⁴ |
| Section Modulus (S) | 0.205 | In ³ | 0.297 | In ³ |
| Radius of Gyration (r) | 0.655 | In | 0.755 | In |

NR = Not Recommended.

** $KL/r > 200$

- Notes:
- Above loads include the weight of the member. This must be deducted to arrive at the net allowable load the beam will support.
 - Long span beams should be supported in such a manner as to prevent rotation and twist.
 - Allowable uniformly distributed loads are listed for various simple spans, that is, a beam on two supports. If load is concentrated at the center of the span, multiply load from the table by 0.5 and corresponding deflection by 0.8.

1 5/8" Channel
 Telestrut System
 Nuts & Hardware
 General Fittings
 Pipe/Conduit Supports
 Electrical Fittings
 Concrete Inserts
 1 1/4" Framing System
 1 3/8" Framing System
 Fiberglass System
 Special Metals
 PrimeAngle System
 Product Index

P9000 - BEAM LOADING (METRIC)

| Span mm | Max Allowable Uniform Load kN | Defl. at Uniform Load mm | Uniform Loading at Deflection | | |
|------------|--|-----------------------------------|-------------------------------|----------------|----------------|
| | | | Span/180 kN | Span/240 kN | Span/360 kN |
| 600 | 7.7 | 2 | 7.7 | 7.7 | 7.7 |
| 750 | 6.2 | 2 | 6.2 | 6.2 | 5.3 |
| 1,000 | 4.7 | 4 | 4.7 | 4.5 | 3.0 |
| 1,250 | 3.7 | 7 | 3.7 | 2.9 | 1.9 |
| 1,500 | 3.1 | 10 | 2.7 | 2.0 | 1.3 |
| 1,750 | 2.7 | 13 | 2.0 | 1.5 | 1.0 |
| 2,000 | 2.3 | 17 | 1.5 | 1.1 | 0.8 |
| 2,500 | 1.9 | 27 | 1.0 | 0.7 | 0.5 |
| 3,000 | 1.6 | 39 | 0.7 | 0.5 | 0.3 |
| 3,500 | 1.3 | 53 | 0.5 | 0.4 | 0.3 |
| 4,000 | 1.2 | 68 | 0.4 | 0.3 | 0.2 |
| 4,500 | 1.0 | 86 | 0.3 | 0.2 | 0.1 |
| 5,000 | 0.9 | 108 | 0.2 | 0.2 | NR |
| 6,000 | 0.8 | 151 | 0.2 | NR | NR |

P9200 - BEAM LOADING (METRIC)

| Span mm | Max Allowable Uniform Load kN | Defl. at Uniform Load mm | Uniform Loading at Deflection | | |
|------------|--|-----------------------------------|-------------------------------|----------------|----------------|
| | | | Span/180 kN | Span/240 kN | Span/360 kN |
| 600 | 11.3 | 1 | 11.3 | 11.3 | 11.3 |
| 750 | 9.0 | 2 | 9.0 | 9.0 | 8.9 |
| 1,000 | 6.8 | 4 | 6.8 | 6.8 | 5.0 |
| 1,250 | 5.4 | 6 | 5.4 | 4.8 | 3.2 |
| 1,500 | 4.5 | 8 | 4.5 | 3.3 | 2.2 |
| 1,750 | 3.9 | 11 | 3.3 | 2.4 | 1.6 |
| 2,000 | 3.4 | 15 | 2.5 | 1.9 | 1.2 |
| 2,500 | 2.7 | 23 | 1.6 | 1.2 | 0.8 |
| 3,000 | 2.3 | 34 | 1.1 | 0.8 | 0.6 |
| 3,500 | 1.9 | 45 | 0.8 | 0.6 | 0.4 |
| 4,000 | 1.7 | 60 | 0.6 | 0.5 | 0.3 |
| 4,500 | 1.5 | 76 | 0.5 | 0.4 | 0.3 |
| 5,000 | 1.3 | 92 | 0.4 | 0.3 | 0.2 |
| 6,000 | 1.1 | 132 | 0.3 | 0.2 | NR |

P9000 - COLUMN LOADING (METRIC)

| Unbraced Height mm | Maximum Allowable Load at Slot Face kN | Maximum Column Load Applied at C.G. | | | |
|--------------------------|--|-------------------------------------|----------------|---------------|---------------|
| | | K = 0.65 kN | K = 0.80 kN | K = 1.0 kN | K = 1.2 kN |
| 600 | 16.2 | 38.9 | 38.2 | 37.1 | 35.9 |
| 750 | 16.0 | 38.2 | 37.1 | 35.5 | 33.7 |
| 1,000 | 15.6 | 36.7 | 35.0 | 32.3 | 29.4 |
| 1,250 | 15.0 | 34.8 | 32.3 | 28.6 | 24.6 |
| 1,500 | 14.4 | 32.6 | 29.4 | 24.6 | 19.8 |
| 1,750 | 13.6 | 30.3 | 26.2 | 20.6 | 15.3 |
| 2,000 | 12.7 | 27.8 | 23.0 | 16.8 | 11.7 |
| 2,250 | 11.7 | 25.2 | 19.8 | 13.3 | 9.3 |
| 2,500 | 10.5 | 22.6 | 16.8 | 10.8 | 7.5 |
| 2,750 | 9.3 | 20.0 | 14.0 | 8.9 | 6.2 |

P9200 - COLUMN LOADING (METRIC)

| Unbraced Height mm | Maximum Allowable Load at Slot Face kN | Maximum Column Load Applied at C.G. | | | |
|--------------------------|---|-------------------------------------|----------------|---------------|---------------|
| | | K = 0.65 kN | K = 0.80 kN | K = 1.0 kN | K = 1.2 kN |
| 600 | 20.6 | 49.5 | 48.9 | 47.9 | 46.6 |
| 750 | 20.4 | 48.8 | 47.9 | 46.3 | 44.4 |
| 1,000 | 20.0 | 47.4 | 45.7 | 43.1 | 40.1 |
| 1,250 | 19.5 | 45.6 | 43.1 | 39.3 | 35.1 |
| 1,500 | 18.8 | 43.5 | 40.1 | 35.1 | 29.9 |
| 1,750 | 18.1 | 41.1 | 36.8 | 30.7 | 24.6 |
| 2,000 | 17.2 | 38.5 | 33.4 | 26.3 | 19.7 |
| 2,250 | 16.2 | 35.7 | 29.9 | 22.1 | 15.6 |
| 2,500 | 15.1 | 32.9 | 26.3 | 18.2 | 12.6 |
| 2,750 | 13.9 | 30.1 | 23.0 | 15.0 | 10.4 |

P9000/P9200 - ELEMENTS OF SECTION (METRIC)

| Parameter | P9000 | P9200 |
|------------------------|----------------------|-----------------------|
| Area of Section | 2.50 cm ² | 3.16 cm ² |
| Axis 1-1 | | |
| Moment of Inertia (I) | 6.92 cm ⁴ | 11.61 cm ⁴ |
| Section Modulus (S) | 3.35 cm ³ | 4.87 cm ³ |
| Radius of Gyration (r) | 1.66 cm | 1.92 cm |
| Axis 2-2 | | |
| Moment of Inertia (I) | 6.92 cm ⁴ | 11.61 cm ⁴ |
| Section Modulus (S) | 3.35 cm ³ | 4.87 cm ³ |
| Radius of Gyration (r) | 1.66 cm | 1.92 cm |

NR = Not Recommended.

- Notes:
1. Above loads include the weight of the member. This must be deducted to arrive at the net allowable load the beam will support.
 2. Long span beams should be supported in such a manner as to prevent rotation and twist.
 3. Allowable uniformly distributed loads are listed for various simple spans, that is, a beam on two supports. If load is concentrated at the center of the span, multiply load from the table by 0.5 and corresponding deflection by 0.8.



P9010

MULTI-GRIP RIVET

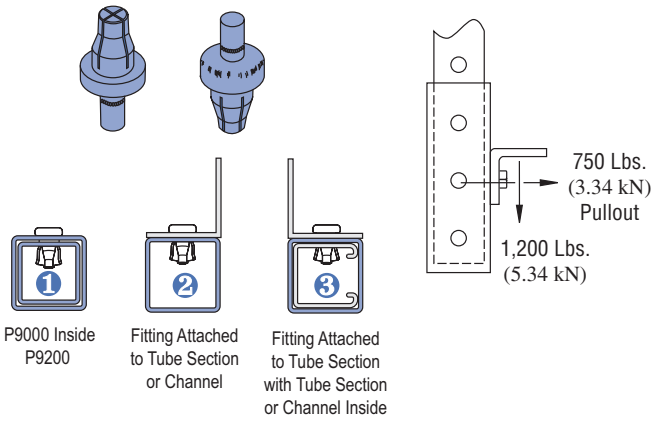

Wt/100 pcs: 10 Lbs (4.5 kg)

P9209

GRAVITY PIN

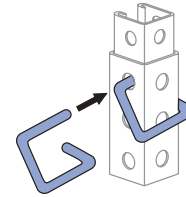

Wt/100 pcs: 47 Lbs (21.3 kg)

P9207

CUTTING ALIGNMENT GAUGE

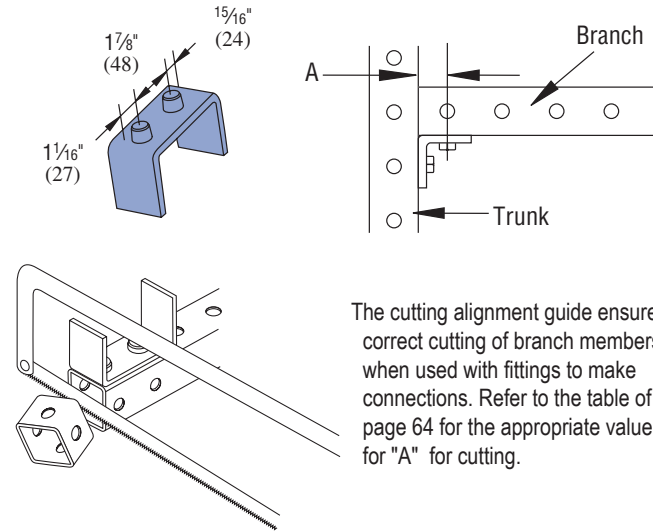

P9324

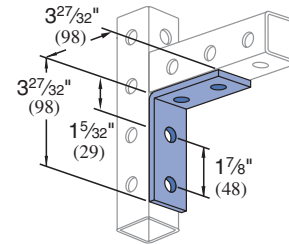

Wt/100 pcs: 78 Lbs (35.0 kg)

P9011

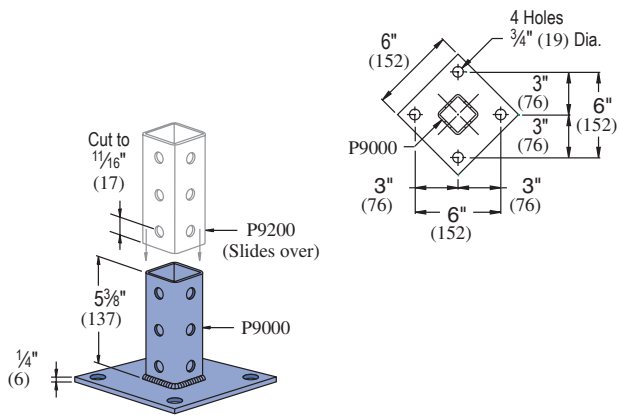

Wt/100 pcs: 332 Lbs (150.7 kg)

P9012

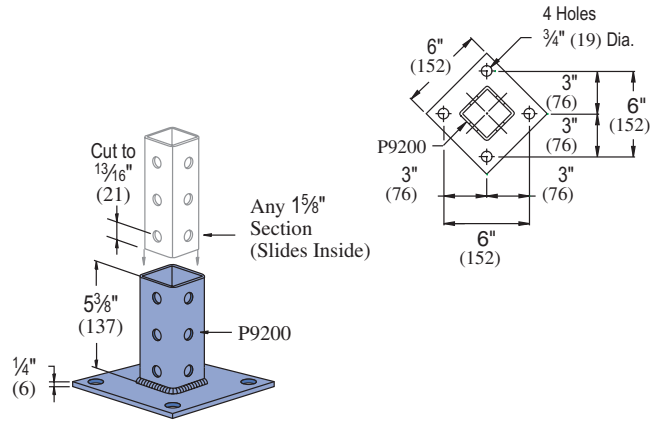

Wt/100 pcs: 340 Lbs (154 kg)

Standard Dimensions for 1 5/8" (41mm) width series channel fittings (Unless Otherwise Shown on Drawing)

Hole Diameter: 9/16" (14mm); Hole Spacing - From End: 1 3/16" (21mm); Hole Spacing - On Center: 1 7/8" (48mm); Width: 1 5/8" (41mm); Thickness: 1/4" (6mm)

P9014

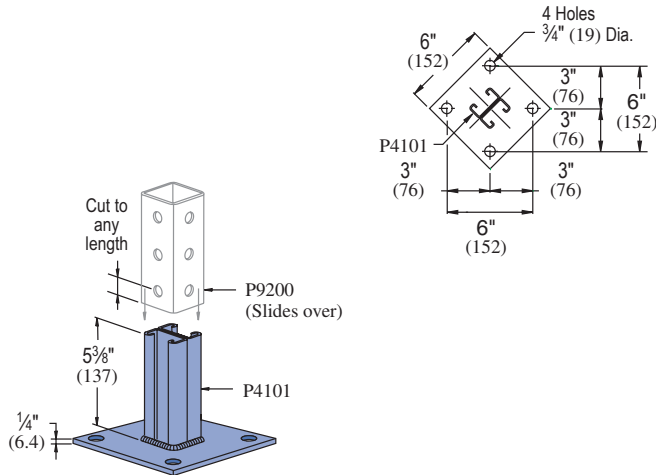

Wt/100 pcs: 303 Lbs (137.5 kg)

PREFERRED THREE-PIECE ASSEMBLY

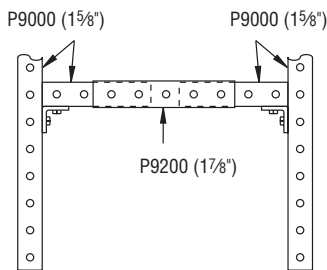

In most applications, telescoping assemblies should be made from three sections of Telestrut material. The simplest construction utilizes a center section of 1 7/8" material (P9200) into which a 1 5/8" member (P9000) is telescoped from each end. In this way, all intersecting verticals and horizontals are formed from 1 5/8" members assuring maximum compatibility and ease of assembly

TWO-PIECE ASSEMBLY

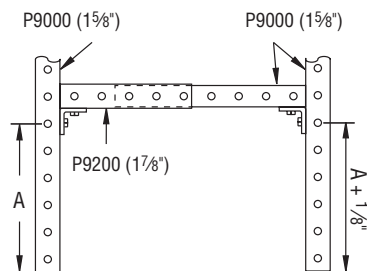

Two-piece telescoping assemblies can be used, but special cutting of one or both telescoping members is needed to achieve proper alignment of fittings at the intersecting connections.

In addition, the right-angle members to which telescoping pieces are attached must be cut according to the illustration at right to insure smooth movement of telescoping members.

P9013

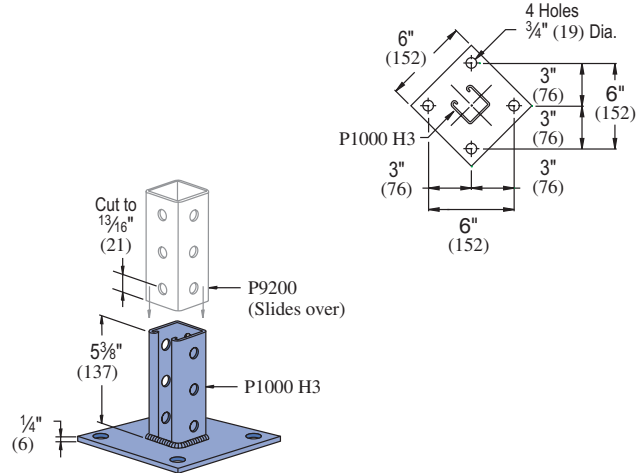

Wt/100 pcs: 318 Lbs (144.7 kg)

ALTERNATE THREE-PIECE ASSEMBLY

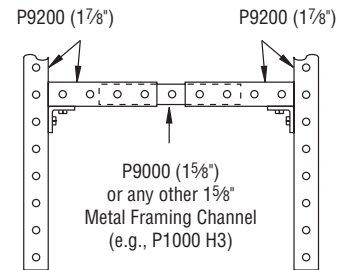

A similar technique is to use a center 1 5/8" center member (P9000) which can be telescoped into 1 7/8" members used at both ends. With this method, all intersecting connections should be formed from compatible 1 7/8" members.

CHANNEL NUT CONNECTION – INFINITE ADJUSTMENT

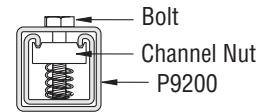

Any of the 1 5/8" (41 mm) channel can be connected to the P9000 using standard channel nuts.

THROUGH-BOLT CONNECTION – INCREMENTAL ADJUSTMENT

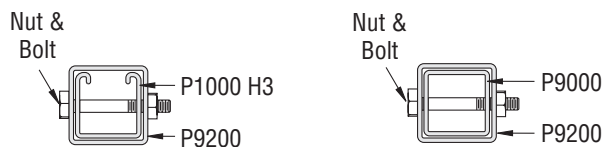

Standard Dimensions for 1 5/8" (41mm) width series channel fittings (Unless Otherwise Shown on Drawing)

Hole Diameter: 9/16" (14mm); Hole Spacing - From End: 13/16" (21mm); Hole Spacing - On Center: 1 1/8" (48mm); Width: 1 5/8" (41mm); Thickness: 1/4" (6mm)



CUTTING CHART

| Fitting | 1½" (41.3) Branch | | 1⅞" (47.6) Branch | |
|---------|---------------------|---------------------|---------------------|---------------------|
| | Trunk 1½" (41.3) | Trunk 1⅞" (47.6) | Trunk 1½" (41.3) | Trunk 1⅞" (47.6) |
| P1026 | A | A | A | B |
| P1028 | A | A | A | B |
| P1029 | † | † | † | † |
| P1031 | A | A | A | B |
| P1033 | B | A | A | B |
| P1034 | † | † | † | † |
| P1035 | A | † | † | † |
| P1036 | A | A | A | B |
| P1037 | † | † | † | † |
| P1038 | † | † | † | † |
| P1045 | † | † | † | † |
| P1047 | † | † | † | † |
| P1048 | † | † | † | † |
| P1049 | † | † | † | † |
| P1050 | † | † | † | † |
| P1065 | A | A | A | B |
| P1066 | A | A | A | B |
| P1068 | C | NR | NR | NR |
| P1130 | A | A | A | C |
| P1131 | A | A | A | C |
| P1290 | A | NR | NR | NR |
| P1291 | A | NR | NR | NR |
| P1325 | A | NR | NR | NR |
| P1326 | C | NR | NR | NR |
| P1334 | A | A | A | B |
| P1346 | A | A | A | B |
| P1347 | C | NR | NR | NR |
| P1354 | D | D | D | D |
| P1356 | A | A | A | B |
| P1357 | A | NR | NR | NR |
| P1358 | A | A | A | B |
| P1359 | A | NR | NR | NR |
| P1380 | A | A | A | B |
| P1380 A | A | A | A | B |
| P1381 | † | † | † | † |
| P1382 | † | † | † | † |
| P1458 | A | NR | NR | NR |
| P1498 | † | † | † | † |
| P1499 | † | † | † | † |
| P1538 A | C | A | A | C |
| P1538 B | C | A | A | C |
| P1538 C | C | A | A | C |
| P1538 D | C | A | A | C |
| P1579 | A | NR | NR | NR |
| P1713 | † | † | † | † |

| Fitting | 1½" (41.3) Branch | | 1⅞" (47.6) Branch | |
|-----------|---------------------|---------------------|---------------------|---------------------|
| | Trunk 1½" (41.3) | Trunk 1⅞" (47.6) | Trunk 1½" (41.3) | Trunk 1⅞" (47.6) |
| P1726 | A | A | A | B |
| P1727 | B | NR | NR | NR |
| P1728 | † | † | † | † |
| P1747 | † | † | † | † |
| P1750 | † | † | † | † |
| P1821 | † | † | † | † |
| P1822 | † | † | † | † |
| P1823 | † | † | † | † |
| P1843 | D | D | D | D |
| P1873 | † | † | † | † |
| P1834 | † | NR | NR | NR |
| P1941 | A | A | A | B |
| P1950 | A | A | A | B |
| P1953 | A | A | A | B |
| P1956 | † | † | † | † |
| P1957 | † | † | † | † |
| P2223 | A | NR | A | NR |
| P2224 | A | NR | A | NR |
| P2225 | A | NR | A | NR |
| P2226 | A | NR | A | NR |
| P2227 | A | NR | A | NR |
| P2228 | A | NR | A | NR |
| P2229 | A | NR | A | NR |
| P2230 | A | NR | A | NR |
| P2235 | A | NR | NR | NR |
| P2245 | A | NR | A | NR |
| P2324 | E | NR | NR | F |
| P2325 | E | A | A | F |
| P2326 | E | NR | NR | F |
| P2341 R-L | A | NR | A | NR |
| P2343 R-L | A | NR | A | NR |
| P2344 R-L | A | NR | A | NR |
| P2345 | A | NR | A | NR |
| P2346 | A | NR | A | NR |
| P2347 | A | NR | A | NR |
| P2348 | A | NR | A | NR |
| P2472 R-L | C | NR | A | NR |
| P2815 | C | NR | NR | NR |
| P2815 D | C | NR | NR | NR |
| P9324 | G | G | G | G |
| P9325 | A | A | A | A |
| P9484 | A | A | A | A |

This table shows the value for "A" when using the specified fitting to connect the branch and trunk. Sizes "A" and "B" can be cut with the cutting alignment gauge (P9207). Other sizes require special cutting. Those marked NR are not recommended.

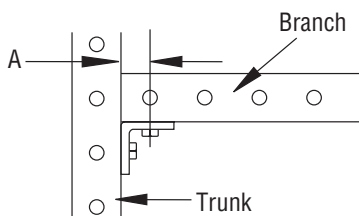

Legend

| Designator | "A" In (mm) |
|------------|----------------|
| A | 11/16" * 27 |
| B | 15/16" * 24 |
| C | 13/16" * 21 |
| D | 1 1/4" * 32 |
| E | 5/8" * 16 |

| Designator | "A" In (mm) |
|------------|--|
| F | 7/16" * 11 |
| G | 1 5/32" * 27 |
| NR | Not Recommended |
| † | Special Cutting Req'd (See part dwg) |

| | |
|------------------------------------|-------|
| Channel Nuts With Springs | 67 |
| Channel Nuts Without Springs | 67 |
| Top Retainer Nuts | 67 |
| Stud Nuts | 68 |
| Hardware | 68-70 |

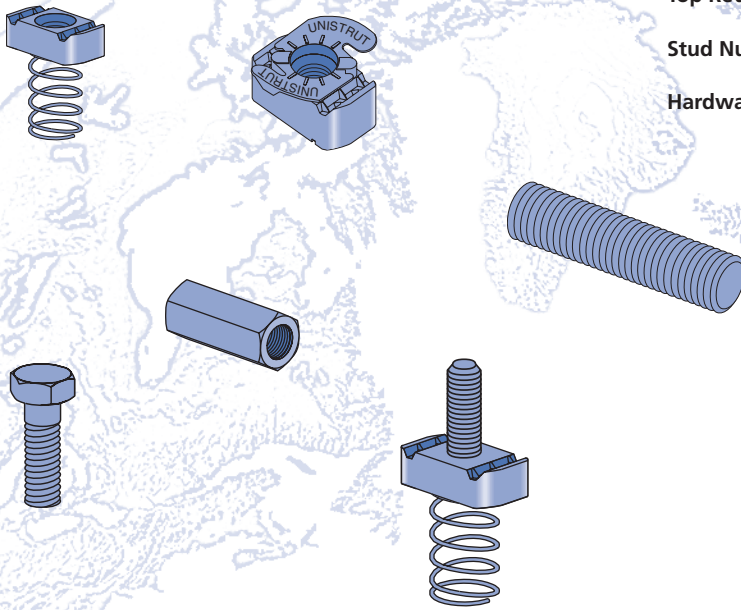

MATERIAL

Unistrut channel nuts are manufactured from mild steel bars, and after machining operations are completed, they are case hardened, assuring positive biting action into the inturned edge of the Unistrut channel.

| Bolt Size | Channel Nut ASTM |
|--------------------|----------------------|
| 1/4" & 5/16" | A1011 SS GR45 |
| 3/8", 7/16" & 1/2" | A576 GR1015 Modified |
| 5/8" & 3/4" | A36 or A675 GR60 |
| 7/8" | A36 |

FINISHES

Nuts, bolts and washers are electro-galvanized (EG), ASTM B633 Type III SC1 finish, unless otherwise noted.

Many hardware items are also available in stainless steel. Consult factory for ordering information.

THREADS

All threads on the nuts and bolts are Unified and American coarse screw threads.

DESIGN BOLT TORQUE

| BOLT SIZE | 1/4"-20 | 5/16"-18 | 3/8"-16 | 1/2"-13 | 5/8"-11 | 3/4"-10 |
|-------------------------------------|----------|------------|------------|------------|--------------|--------------|
| Rec.Torque Ft/Lbs (<i>N·m</i>) | 6 (8) | 11 (15) | 19 (26) | 50 (68) | 100 (136) | 125 (170) |
| Max Torque Ft/Lbs (<i>N·m</i>) | 7 (9) | 15 (20) | 25 (34) | 70 (95) | 125 (170) | 135 (183) |

DIMENSIONS

Imperial dimensions are illustrated in inches. Metric dimensions are shown in parenthesis or as noted.

Unless noted, all metric dimensions are in millimeters and rounded to one decimal place.

Many Unistrut nuts, bolts and hardware items are also available in standard metric dimensions. Consult factory for ordering information.



Channel Nuts With Spring

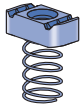

P1006 - P1010
Pg 67

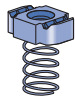

P1012S - P1024S
Pg 67



P4006 - P4010
Pg 67



P4012S - P4023S
Pg 67



P5506 - P5510
Pg 67

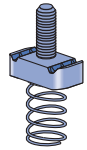

P2378 - P2382
Pg 68

Channel Nuts Without Spring



P3016
Pg 67



P3006 - P3013
Pg 67



P1012 - P1024
Pg 67



P4012 - P4023
Pg 67



P1006T - P1010T, P4010T
Pg 67

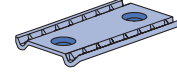

P4908
Pg 67



P1016
Pg 67

Hardware



HHCS
Pg 68



HFMS
Pg 68



HRMS
Pg 68



HSHS
Pg 68



HCSS
Pg 68



HSQN
Pg 69



HHXN
Pg 69



HFLW
Pg 69



HLKW
Pg 69

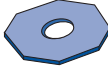

HOCW
Pg 70

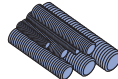

HTHR
Pg 69



HRCN
Pg 69



P2486
Pg 70



P2485
Pg 70

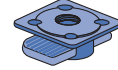

K1062 - K1064
Pg 70

MAXIMUM ALLOWABLE PULL-OUT AND SLIP LOADS

| Channel | Channel Nut Size-Thread | Gauge | Allowable Pull-Out Strength Lbs (kN) | Resistance to Slip Lbs (kN) | Torque Ft-Lbs (N·m) |
|----------------------------------|-------------------------|-------|--------------------------------------|-----------------------------|---------------------|
| P1000 P3000 P5000 P5500 | 3/4" - 10 | 12 | 2,500 | 1,700 | *125 |
| | | | 11.12 | 7.56 | 170 |
| | 5/8" - 11 | 12 | 2,500 | 1,500 | *100 |
| | | | 11.12 | 6.67 | 135 |
| | 1/2" - 13 | 12 | 2,000 | 1,500 | 50 |
| | | | 8.90 | 6.67 | 70 |
| | 7/16" - 14 | 12 | 1,400 | 1,000 | 35 |
| | | | 6.23 | 4.45 | 50 |
| 3/8" - 16 | 12 | 1,000 | 800 | 19 | |
| | | 4.45 | 3.56 | 25 | |
| 5/16" - 18 | 12 | 800 | 500 | 11 | |
| | | 3.56 | 2.22 | 15 | |
| 1/4" - 20 | 12 | 600 | 300 | 6 | |
| | | 2.67 | 1.33 | 8 | |
| P3300 | 1/2" - 13 | 12 | 1,500 | 1,500 | 50 |
| | | | 6.67 | 6.67 | 70 |
| | 3/8" - 16 | 12 | 1,000 | 800 | 19 |
| | | | 4.45 | 3.56 | 25 |
| 5/16" - 18 | 12 | 800 | 500 | 11 | |
| | | 3.56 | 2.22 | 15 | |
| 1/4" - 20 | 12 | 600 | 300 | 6 | |
| | | 2.67 | 1.33 | 8 | |

| Channel | Channel Nut Size-Thread | Gauge | Allowable Pull-Out Strength Lbs (kN) | Resistance to Slip Lbs (kN) | Torque Ft-Lbs (N·m) |
|---------------|-------------------------|-------|--------------------------------------|-----------------------------|---------------------|
| P1100 & P4100 | 1/2" - 13 | 14 | 1,400 | 1,000 | 50 |
| | | | 6.23 | 4.45 | 70 |
| | 3/8" - 16 | 14 | 1,000 | 750 | 19 |
| | | | 4.45 | 3.34 | 25 |
| | 5/16" - 18 | 14 | 800 | 400 | 11 |
| 3.56 | | | 1.78 | 15 | |
| 1/4" - 20 | 14 | 600 | 300 | 6 | |
| | | 2.67 | 1.33 | 8 | |
| P2000 & P4000 | 1/2" - 13 | 16 | 1,000 | 1,000 | 50 |
| | | | 4.45 | 4.54 | 70 |
| | 3/8" - 16 | 16 | 1,000 | 750 | 19 |
| | | | 4.45 | 3.34 | 25 |
| | 5/16" - 18 | 16 | 800 | 400 | 11 |
| 3.56 | | | 1.78 | 15 | |
| 1/4" - 20 | 16 | 600 | 300 | 6 | |
| | | 2.67 | 1.33 | 8 | |

* May require 3/8" or 1/2" thick fitting.

Nut design loads include a minimum safety factor of 3.

Note: Refer to the Channel Nut Selection Chart on the following two pages for the part number.

CHANNEL NUT WITH SPRING

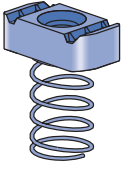
|  | Part Number | Nut Size Thread | Wt/100 pcs Lbs (kg) | Use With |
|---|-------------|-----------------|---------------------|----------------------------|
| | P1006-0832 | #8 -32 | 7 (3.2) | P1000, P1100, P2000, P3000 |
| P1006-1024 | #10 -24 | 7 (3.2) | | |
| P1006-1420 | ¼" -20 | 7 (3.2) | | |
| P1007 | ⅝" -18 | 6 (2.7) | | |
| P1008 | ⅜" -16 | 10 (4.5) | | |
| P1009 | ⅞" -14 | 9 (4.1) | | |
| P1010 | ½" -13 | 12 (5.4) | | |

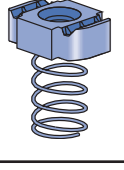
|  | Part Number | Nut Size Thread | Wt/100 pcs Lbs (kg) | Use With |
|---|-------------|-----------------|---------------------|----------------------------|
| | P1012S | ⅝" -11 | 21 (9.5) | P1000, P1100, P2000, P3000 |
| P1023S | ¾" -10 | 21 (9.5) | | |
| P1024S | ⅞" -9 | 21 (9.5) | | |

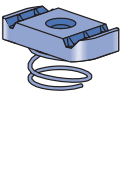
|  | Part Number | Nut Size Thread | Wt/100 pcs Lbs (kg) | Use With |
|--|-------------|-----------------|---------------------|---------------------|
| | P4006-0832 | #8 -32 | 7 (3.2) | P3300, P4000, P4100 |
| P4006-1024 | #10 -24 | 7 (3.2) | | |
| P4006-1420 | ¼" -20 | 7 (3.2) | | |
| P4007 | ⅝" -18 | 6 (2.7) | | |
| P4008 | ⅜" -16 | 9 (4.1) | | |
| P4009 | ⅞" -14 | 9 (4.1) | | |
| P4010 | ½" -13 | 8 (3.6) | | |

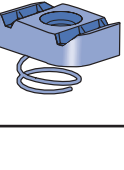
|  | Part Number | Nut Size Thread | Wt/100 pcs Lbs (kg) | Use With |
|---|-------------|-----------------|---------------------|---------------------|
| | P4012S | ⅝" -11 | 10 (4.5) | P3300, P4000, P4100 |
| P4023S | ¾" -10 | 10 (4.5) | | |

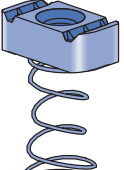
|  | Part Number | Nut Size Thread | Wt/100 pcs Lbs (kg) | Use With |
|---|-------------|-----------------|---------------------|----------|
| | P5506-0832 | #8 -32 | 7 (3.2) | P5500 |
| P5506-1024 | #10 -24 | 7 (3.2) | | |
| P5506-1420 | ¼" -20 | 7 (3.2) | | |
| P5507 | ⅝" -18 | 6 (2.7) | | |
| P5508 | ⅜" -16 | 10 (4.5) | | |
| P5509 | ⅞" -14 | 10 (4.5) | | |
| P5510 | ½" -13 | 12 (5.4) | | |

CHANNEL NUT WITHOUT SPRING

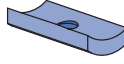
|  | Part Number | Nut Size Thread | Wt/100 pcs Lbs (kg) | Use With |
|---|-------------|-----------------|---------------------|-------------|
| | P3016-0632 | #6 -32 | 2 (0.9) | Any Channel |
| P3016-0832 | #8 -32 | 2 (0.9) | | |
| P3016-1024 | #10 -24 | 4 (1.8) | | |
| P3016-1420 | ¼" -20 | 4 (1.8) | | |

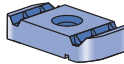
|  | Part Number | Nut Size Thread | Wt/100 pcs Lbs (kg) | Use With |
|---|-------------|-----------------|--|-------------|
| | P3006-0832 | #8 -32 | 6 (2.7) | Any Channel |
| P3006-1024 | #10 -24 | 6 (2.7) | | |
| P3006-1420 | ¼" -20 | 6 (2.7) | | |
| P3007 | ⅝" -18 | 6 (2.7) | | |
| P3008 | ⅜" -16 | 9 (4.1) | | |
| P3009 | ⅞" -14 | 9 (4.1) | | |
| P3010 | ½" -13 | 11 (5.0) | Any Channel Except P3300, P4000, P4100 | |

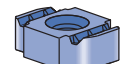
|  | Part Number | Nut Size Thread | Wt/100 pcs Lbs (kg) | Use With |
|--|-------------|-----------------|---------------------|---------------------|
| | P3013 | ½" -13 | 8 (3.6) | P3300, P4000, P4100 |

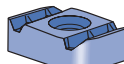
|  | Part Number | Nut Size Thread | Wt/100 pcs Lbs (kg) | Use With |
|---|-------------|-----------------|---------------------|--|
| | P1012 | ⅝" -11 | 20 (9.1) | Any Channel Except P3300, P4000, P4100 |
| P1023 | ¾" -10 | 20 (9.1) | | |
| P1024 | ⅞" -9 | 20 (9.1) | | |

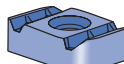
|  | Part Number | Nut Size Thread | Wt/100 pcs Lbs (kg) | Use With |
|---|-------------|-----------------|---------------------|---------------------|
| | P4012 | ⅝" -11 | 11 (5.0) | P3300, P4000, P4100 |
| P4023 | ¾" -10 | 11 (5.0) | | |

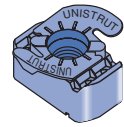
|  | Part Number | Nut Size Thread | Wt/100 pcs Lbs (kg) | Use With |
|---|-------------|-----------------|--|-------------|
| | P1006T1420 | ¼" -20 | 7 (3.2) | Any Channel |
| P1008T | ⅜" -16 | 10 (4.5) | | |
| P1010T | ½" -13 | 12 (5.4) | Any Channel Except P3300, P4000, P4100 | |
| P4010T | ½" -13 | 8 (3.6) | P3300, P4000, P4100 | |

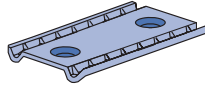
|  | Part Number | Nut Size Thread | Wt/100 pcs Lbs (kg) | Use With |
|--|-------------|-----------------|---------------------|-------------|
| | P4908 | ⅝" -16 | 17.5 (7.9) | Any Channel |
| Double Conveyor Adjusting Nut | | | | |

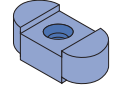
|  | Part Number | Nut Size Thread | Wt/100 pcs Lbs (kg) | Use With |
|---|-------------|-----------------|---------------------|---------------------|
| | P1016 | ⅝" -16 | 17.5 (7.9) | Any Slotted Channel |
| Missing Link Multi-Purpose Strut Fastener | | | | |



CHANNEL STUD NUT WITH SPRING

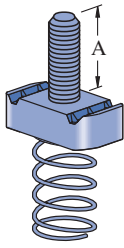

All Stud Nut grooves are serrated.

Special stud lengths and thread lengths can be supplied upon request.

| Part No. | Thread | "A" Stud In (mm) | Wt/100 pcs Lbs (kg) |
|----------|---------|------------------|---------------------|
| P2378-1 | ¼" - 20 | 1 (25) | 8 (3.6) |
| P2378-2 | | 1¼ (31) | 9 (4.1) |
| P2378-3 | | 1½ (38) | 9 (4.1) |
| P2379-1 | ⅝" - 18 | 1 (25) | 12 (5.4) |
| P2379-2 | | 1¼ (32) | 12 (5.4) |
| P2379-3 | | 1½ (38) | 13 (5.9) |
| P2380-1 | | 1 (25) | 13 (5.9) |
| P2380-2 | ¾" - 16 | 1¼ (32) | 13 (5.9) |
| P2380-3 | | 1½ (38) | 13 (5.9) |
| P2380-4 | | 1¾ (45) | 15 (6.8) |

Use With P1000, P1100, P2000, P3000

| Part No. | Thread | "A" Stud In (mm) | Wt/100 pcs Lbs (kg) |
|----------|---------|------------------|---------------------|
| P2380-5 | ⅜" - 16 | 2 (51) | 16 (7.3) |
| P2380-6 | | 2¼ (57) | 16 (7.3) |
| P2381-2 | ½" - 13 | 1 (25) | 14 (6.4) |
| P2381-3 | | 1¼ (32) | 15 (6.8) |
| P2381-4 | | 1½ (38) | 17 (7.7) |
| P2381-5 | | 1¾ (45) | 18 (8.2) |
| P2381-6 | | 2 (51) | 19 (8.6) |
| P2381-7 | | 2¼ (57) | 20 (9.1) |
| P2382-2 | ⅝" - 11 | 1¼ (32) | 18 (8.2) |
| P2382-3 | | 1½ (38) | 20 (9.1) |

Use With P1000, P1100, P2000, P3000

HEX HEAD CAP SCREWS

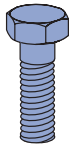

| Part No. | Size | Wt/100 pcs Lbs (kg) |
|--------------|-------------|---------------------|
| HHCS025044EG | ¼" x 7/16" | 1.0 (0.5) |
| HHCS025075EG | ¼" x ¾" | 1.3 (0.6) |
| HHCS025150EG | ¼" x 1½" | 2.6 (1.2) |
| HHCS031125EG | ⅝" x 1¼" | 3.6 (1.6) |
| HHCS037075EG | ¾" x ¾" | 4.0 (1.8) |
| HHCS037087EG | ¾" x 7/8" | 4.4 (2.0) |
| HHCS037100EG | ¾" x 1" | 4.5 (2.0) |
| HHCS037125EG | ¾" x 1¼" | 5.3 (2.4) |
| HHCS037150EG | ¾" x 1½" | 6.0 (2.7) |
| HHCS037200EG | ¾" x 2" | 7.6 (3.4) |
| HHCS037225EG | ¾" x 2¼" | 8.4 (3.8) |
| HHCS037250EG | ¾" x 2½" | 9.2 (4.2) |
| HHCS050094EG | ½" x 15/16" | 9.1 (4.2) |
| HHCS050119EG | ½" x 1¾" | 10.2 (4.6) |
| HHCS050150EG | ½" x 1½" | 11.6 (5.3) |
| HHCS050175EG | ½" x 1¾" | 13.1 (5.9) |
| HHCS050200EG | ½" x 2" | 14.6 (6.6) |
| HHCS050225EG | ½" x 2¼" | 16 (7.3) |
| HHCS050250EG | ½" x 2½" | 17.5 (7.9) |

HEX SLOTTED MACHINE SCREWS



| Part No. | Size | Wt/100 pcs Lbs (kg) |
|--------------|----------|---------------------|
| HSHS025050EG | ¼" x ½" | 1.4 (0.6) |
| HSHS025062EG | ¼" x ⅝" | 1.5 (0.7) |
| HSHS025075EG | ¼" x ¾" | 1.7 (0.8) |
| HSHS031100EG | ⅝" x 1" | 2.6 (1.2) |
| HSHS031125EG | ⅝" x 1¼" | 3.0 (1.4) |
| HSHS031150EG | ⅝" x 1½" | 3.4 (1.5) |
| HSHS037125EG | ¾" x 1¼" | 5.3 (2.4) |

FLAT HEAD MACHINE SCREWS



| Part No. | Size | Wt/100 pcs Lbs (kg) |
|--------------|---------|---------------------|
| HFMS025062EG | ¼" x ⅝" | 1.2 (0.5) |
| HFMS031100EG | ⅝" x 1" | 2.6 (1.2) |
| HFMS050100EG | ½" x 1" | 9.3 (4.2) |

CONE POINT SET SCREWS



| Part No. | Size | Wt/100 pcs Lbs (kg) |
|--------------|----------|---------------------|
| HCSS025100EG | ¼" x 1" | 2.8 (1.3) |
| HCSS031150EG | ⅝" x 1½" | 3.9 (1.8) |
| HCSS037150EG | ¾" x 1½" | 4.5 (2.0) |
| HCSS037200EG | ¾" x 2" | 6.1 (2.8) |
| HCSS050150EG | ½" x 1½" | 8.5 (3.9) |
| HCSS050200EG | ½" x 2" | 11.4 (5.2) |
| HCSS062150EG | ⅝" x 1½" | 14.5 (6.6) |
| HCSS062200EG | ⅝" x 2" | 23.0 (10.4) |

ROUND HEAD MACHINE SCREWS



| Part No. | Size | Wt/100 pcs Lbs (kg) |
|--------------|----------|---------------------|
| HRMS025050EG | ¼" x ½" | 1 (0.5) |
| HRMS025075EG | ¼" x ¾" | 1.2 (0.6) |
| HRMS025100EG | ¼" x 1" | 1.5 (0.7) |
| HRMS031100EG | ⅝" x 1" | 2.6 (1.2) |
| HRMS031125EG | ⅝" x 1¼" | 3.0 (1.4) |
| HRMS037100EG | ¾" x 1" | 4.1 (1.9) |
| HRMS037125EG | ¾" x 1¼" | 4.7 (2.1) |
| HRMS037150EG | ¾" x 1½" | 5.3 (2.4) |

15/16" Channel
 Telesrnut System
 Nuts & Hardware
 General Fittings
 Pipe/Conduit Supports
 Electrical Fittings
 Concrete Inserts
 1 1/4" Framing System
 1 3/16" Framing System
 Fiberglass System
 Special Metals
 PrimeAngle System
 Product Index

SQUARE NUTS



| Part No. | Size | Wt/100 pcs Lbs (kg) |
|-----------|------|------------------------|
| HSQN025EG | ¼" | 0.9 (0.4) |
| HSQN031EG | ⅝" | 1.6 (0.7) |
| HSQN037EG | ⅜" | 2.7 (1.2) |
| HSQN050EG | ½" | 5.8 (2.6) |
| HSQN062EG | ⅝" | 10.7 (4.9) |
| HSQN075EG | ¾" | 15.4 (6.9) |
| HSQN087EG | ⅞" | 24.9 (11.3) |
| HSQN100EG | 1" | 36.3 (16.5) |

HEXAGON NUTS



| Part No. | Size | Wt/100 pcs Lbs(kg) |
|-----------|------|-----------------------|
| HHXN025EG | ¼" | 0.6 (0.3) |
| HHXN031EG | ⅝" | 1.2 (0.5) |
| HHXN037EG | ⅜" | 1.6 (0.7) |
| HHXN050EG | ½" | 4.8 (2.2) |
| HHXN062EG | ⅝" | 7.3 (3.3) |
| HHXN075EG | ¾" | 11.9 (5.4) |
| HHXN087EG | ⅞" | 19.0 (8.6) |
| HHXN100EG | 1" | 28.3 (12.8) |

FLAT WASHERS



| Part No. | Size | Wt/100 pcs Lbs(kg) |
|-----------|------|-----------------------|
| HFLW025EG | ¼" | 0.8 (0.4) |
| HFLW031EG | ⅝" | 1.0 (0.5) |
| HFLW037EG | ⅜" | 1.5 (0.7) |
| HFLW050EG | ½" | 3.5 (1.6) |
| HFLW062EG | ⅝" | 7.7 (3.5) |
| HFLW075EG | ¾" | 11.0 (5.0) |
| HFLW087EG | ⅞" | 15.3 (6.9) |
| HFLW100EG | 1" | 18.8 (8.5) |

STEEL THREADED ROD

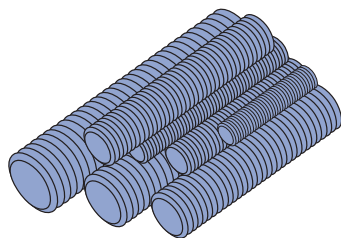

Standard Length 12' (3.7m)

Low Carbon Steel
 F_y = 32,000 psi minimum
 F_t = 52,000 psi minimum

| Part No. | Size | Wt/100 Ft. Lbs (kg) |
|----------|---------|------------------------|
| HTHR025 | ¼" x 20 | 13 (5.9) |
| HTHR031 | ⅝" x 18 | 20 (9.1) |
| HTHR037 | ⅜" x 16 | 30 (13.6) |
| HTHR044 | ⅞" x 14 | 30 (13.6) |
| HTHR050 | ½" x 13 | 53 (24.0) |
| HTHR062 | ⅝" x 11 | 84 (38.1) |
| HTHR075 | ¾" x 10 | 124 (56.2) |
| HTHR087 | ⅞" x 9 | 170 (77.1) |
| HTHR100 | 1" x 8 | 223 (101.2) |

LOCK WASHERS



| Part No. | Size | Wt/100 pcs Lbs (kg) |
|-----------|------|------------------------|
| HLKW025EG | ¼" | 0.25 (0.1) |
| HLKW031EG | ⅝" | 0.41 (0.2) |
| HLKW037EG | ⅜" | 0.63 (0.3) |
| HLKW050EG | ½" | 1.32 (0.60) |
| HLKW062EG | ⅝" | 2.20 (1.0) |
| HLKW075EG | ¾" | 3.80 (1.7) |
| HLKW087EG | ⅞" | 6.00 (2.7) |
| HLKW100EG | 1" | 8.80 (4.0) |

LOAD CARRYING CAPACITY OF THREADED HOT ROLLED STEEL
 CONFORMING TO ASTM A575 AND A576

| Threaded Rod Loads for Piping Applications (based on MSS SP-58) | | |
|---|--|--|
| Nominal Dia. | Root Area In ² (mm ²) | Max. Safe Load at 650°F (343°C) Lbs (kN) |
| ⅜" | 0.068 (43.9) | 730 (3.25) |
| ½" | 0.126 (81.3) | 1,350 (6.01) |
| ⅝" | 0.202 (130.3) | 2,160 (9.61) |
| ¾" | 0.302 (194.8) | 3,230 (14.37) |
| ⅞" | 0.419 (270.3) | 4,480 (19.93) |
| 1" | 0.552 (356.1) | 5,900 (26.24) |

| Threaded Rod Loads for Structural Applications (Based on AISC, Steel Construction Manual, ASD, 9th Edition. Per AISC, Allowed Tensile Stress = 0.33 * F _u) | | |
|--|---|-------------------------------|
| Nominal Dia. | Nominal Area In ² (mm ²) | Allowed Tension Load Lbs (kN) |
| ¼" | 0.049 (31.6) | 840 (3.74) |
| ⅜" | 0.110 (71.0) | 1,890 (8.41) |
| ½" | 0.150 (96.8) | 2,570 (11.43) |
| ⅝" | 0.196 (126.5) | 3,360 (14.95) |
| ¾" | 0.307 (198.2) | 5,260 (23.40) |
| ⅞" | 0.442 (285.4) | 7,580 (33.72) |
| 1" | 0.601 (388.0) | 10,310 (45.86) |
| 1" | 0.785 (506.8) | 13,470 (59.92) |

STEEL COUPLER NUTS

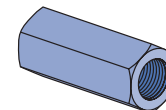

| Part Number | Size | Length In (mm) | Wt/100 pcs Lbs (kg) |
|-------------|---------|----------------|---------------------|
| HRCN025 | ¼" - 20 | ⅞" (22) | 1.9 (0.9) |
| HRCN031 | ⅝" - 18 | 1⅜" (45) | 7.5 (3.4) |
| HRCN037 | ⅜" - 16 | 1⅜" (45) | 9.0 (4.1) |
| HRCN044 | ⅞" - 14 | 1⅜" (45) | 10.4 (4.7) |
| HRCN050 | ½" - 13 | 1⅜" (45) | 10.0 (4.5) |
| HRCN062 | ⅝" - 11 | 2⅞" (54) | 18.0 (8.2) |
| HRCN075 | ¾" - 10 | 2⅞" (57) | 28.0 (12.7) |
| HRCN087 | ⅞" - 9 | 2⅞" (64) | 55.0 (24.9) |
| HRCN100 | 1" - 8 | 2⅞" (70) | 73.0 (33.1) |



SLOT ADAPTER™

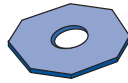
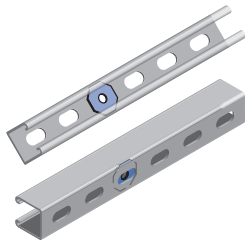

KWIK WASHER™

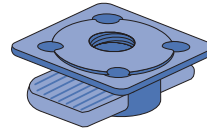

Overhead installation with one hand.
Available in zinc plated and hot dip galvanized

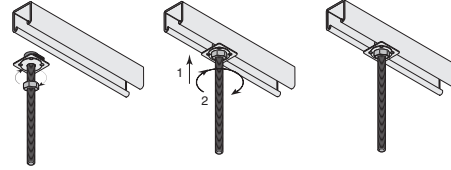

| Part No. | Bolt Size | Wt/100 pcs Lbs (kg) |
|----------|-----------|------------------------|
| HOCW025 | 1/4" (6) | 1 (0.5) |
| HOCW037 | 3/8" (10) | 1.5 (0.7) |

| Part No. | Size In (mm) | Load Lbs (kN) | Wt/100 pcs Lbs (kg) |
|----------|-----------------|------------------|------------------------|
| K1062 | 1/4" (6) | 250 (1.1) | 1.2 (0.5) |
| K1063 | 3/8" (10) | 610 (2.7) | 2.6 (1.2) |
| K1064 | 1/2" (13) | 1,130 (5.0) | 9.3 (4.2) |

P2486

SEISMIC ROD STIFFENER

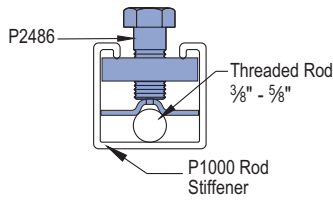
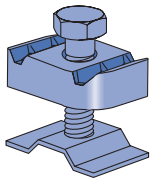

Wt/100 pcs: 16 Lbs (7.3 kg)

P2485

CRADLE CLIP

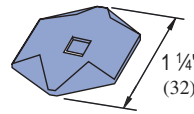

Cradle clip only, order other items separately.

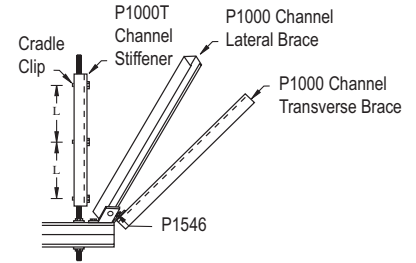
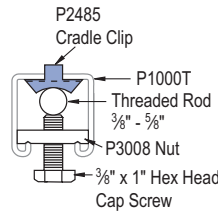

Wt/100 pcs: 3.0 Lbs (1.4 kg)

P2485 & P2486 – SPACING CHART

| Rod Size In (mm) | Root Area In ² (mm ²) | Radius of Gyration In (mm) | Design Load Lbs (kN) |Rod Stiffener Clip Spacing (L)..... | | | |
|---------------------|---|-------------------------------|-------------------------|--|--|--|--|
| | | | | Rod Stress @100% 10,700 PSI In (mm) | Rod Stress @75% 8,025 PSI In (mm) | Rod Stress @50% 5,350 PSI In (mm) | Rod Stress @35% 3,745 PSI In (mm) |
| 3/8 | 0.068 | 0.074 | 730 | 9 | 11 | 13 | 15 |
| 10 | 49.5 | 1.99 | 3.6 | 229 | 279 | 330 | 381 |
| 1/2 | 0.126 | 0.100 | 1,350 | 12 | 14 | 17 | 21 |
| 12 | 72.4 | 2.40 | 5.3 | 305 | 356 | 432 | 533 |
| 5/8 | 0.202 | 0.127 | 2,160 | 15 | 18 | 22 | 26 |
| 16 | 138.3 | 3.32 | 10.2 | 381 | 457 | 559 | 660 |

Notes:

1. Minimum Tensile Stress is 50,000 psi (345MPa)
2. Working Stress is 10,700 psi (73.9 MPa) – Same as for Tension
3. Compression Will Only Occur During a Seismic Event
4. Compression Requires the Use of Rod Stiffeners
5. KL/r = 200 When Rod Stress is at 35%

Refer to seismic bracing systems catalog for more detailed information.

1 1/2" Channel
 Teleslur System
 Nuts & Hardware
 General Fittings
 Pipe/Conduit Supports
 Electrical Fittings
 Concrete Inserts
 1 1/4" Framing System
 1 3/8" Framing System
 Fiberglass System
 Special Metals
 PrimeAngle System
 Product Index



GENERAL FITTINGS

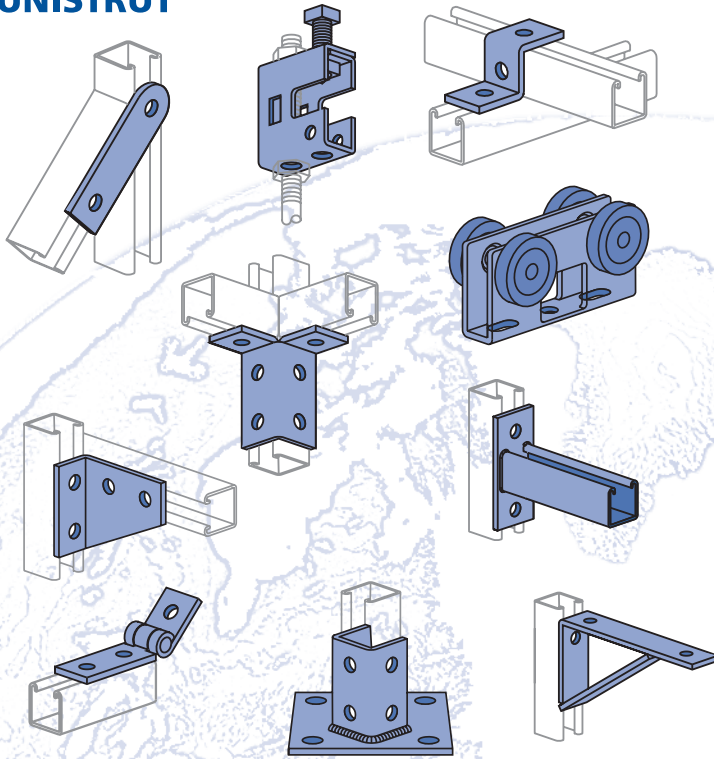

| | |
|-----------------------------------|--------|
| Flat Plate Fittings | 75-76 |
| Ninety Degree Fittings..... | 76-79 |
| Angular Fittings | 79 |
| "Z" Shape Fittings | 80 |
| "U" Shape Fittings | 81-82 |
| Wing Shape Fittings | 82-84 |
| Post Bases | 84 |
| Brackets | 84-87 |
| Brace Fittings..... | 88 |
| Beam Clamps..... | 89-96 |
| Trolleys..... | 96 |
| Special Application Fittings..... | 97-98 |
| Seismic Retrofit Fittings..... | 98-100 |

MATERIAL

Fittings, unless noted, are made from hot-rolled, pickled and oiled steel plates, strip or coil, and conform to ASTM specifications A575, A576, A635, or A36. The fitting steel also meets the physical requirements of ASTM A1011 SS GR 33. The pickling of the steel produces a smooth surface free from scale.

Many fittings are also available in stainless steel, aluminum and fiberglass. Consult factory for ordering information.

FINISHES

Fittings are available in:

- Perma-Green III (GR),
- Electro-galvanized (EG), conforming to ASTM B633 Type III SC1;
- Hot-dipped galvanized (HG), conforming to ASTM A123 or A153 and
- Plain (PL).

APPLICATION

All parts drawings illustrate only one application of each fitting. In most cases many other applications are possible. The channels shown in the illustrations are P1000, 1 $\frac{5}{8}$ " square, except where noted otherwise.

All $\frac{9}{16}$ " diameter holes use $\frac{1}{2}$ " x $\frac{15}{16}$ " hex head cap screws and $\frac{1}{2}$ " nuts - P1010, P4010 or P5510 - depending on the channel used. Nuts and bolts are not included with the fitting and must be ordered separately.

DESIGN BOLT TORQUE

| BOLT SIZE | 1/4"-20 | 5/16"-18 | 3/8"-16 | 1/2"-13 | 5/8"-11 | 3/4"-10 |
|--------------------------|---------|----------|---------|---------|-----------|-----------|
| Rec. Torque Ft/Lbs (N•m) | 6 (8) | 11 (15) | 19 (26) | 50 (68) | 100 (136) | 125 (170) |
| Max Torque Ft/Lbs (N•m) | 7 (9) | 15 (20) | 25 (34) | 70 (95) | 125 (170) | 135 (183) |

SET SCREW TORQUE

| BOLT SIZE | 1/4"-20 | 5/16"-18 | 3/8"-16 | 1/2"-13 | 5/8"-11 | 3/4"-10 |
|-------------------------------|---------|----------|----------|----------|----------|----------|
| Set Screw Torque In/Lbs (N•m) | 40 (4) | 60 (7) | 125 (14) | 250 (28) | 400 (45) | 665 (75) |

Note: Caution should be taken not to overtighten the set screw

DIMENSIONS

Imperial dimensions are illustrated in inches. Metric dimensions are shown in parenthesis or as noted. Unless noted, all metric dimensions are in millimeters and rounded to one decimal place.

DESIGN LOAD

Design load data, where shown, is based on the ultimate strength of the connection with a safety factor of 2.5, unless otherwise noted.

BEAM CLAMPS

Clamps are designed to be used with W, M, S and HP Shape beams, Standard C and Miscellaneous MC Channels, Angles and Structural Tees. Clamps must be used in pairs where indicated. For beam clamps with HG finish, standard hardware is EG finish. For optional stainless steel hardware, please contact the factory for availability.



Flat Plate Fittings

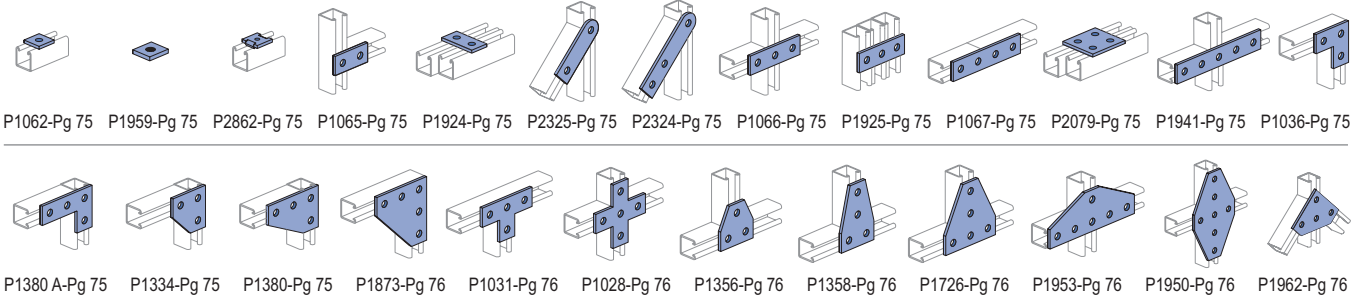

Angle Fittings

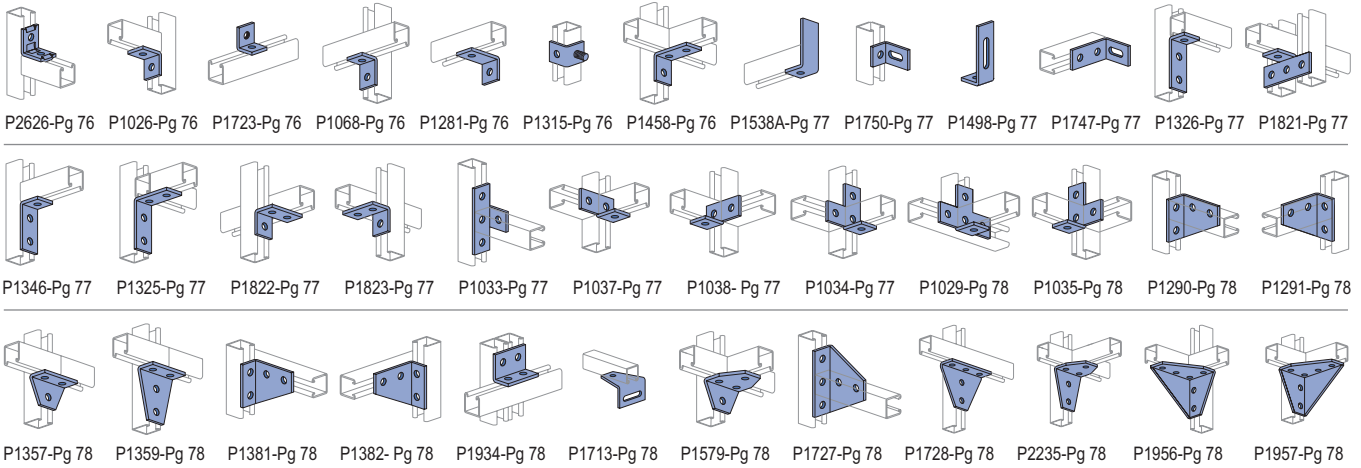

"Z" Shape Fittings

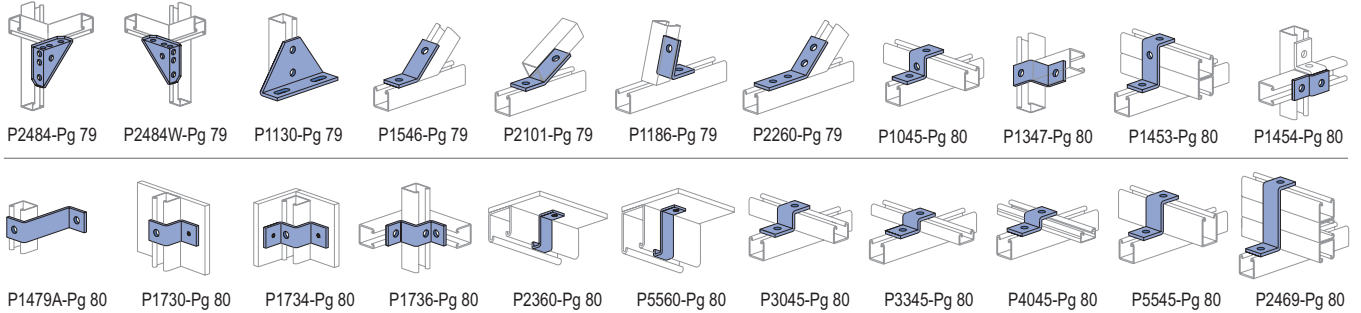

"U" Shape Fittings

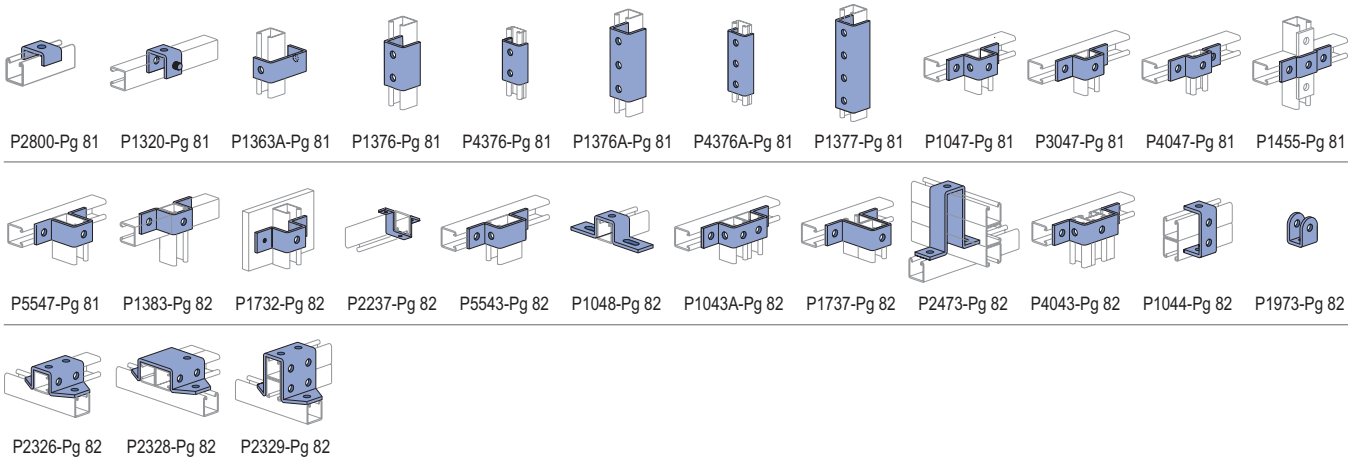

1 1/2" Channel
Telestrut System
Nuts & Hardware

General Fittings

Pipe/Conduit Supports

Electrical Fittings

Concrete Inserts

1 1/4" Framing System

1 3/16" Framing System

Fiberglass System

Special Metals

PrimeAngle System

Product Index

Wing Shape Fittings

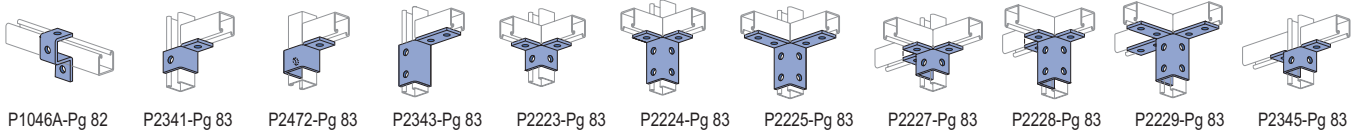

Post Bases



Brackets and Brace Fittings

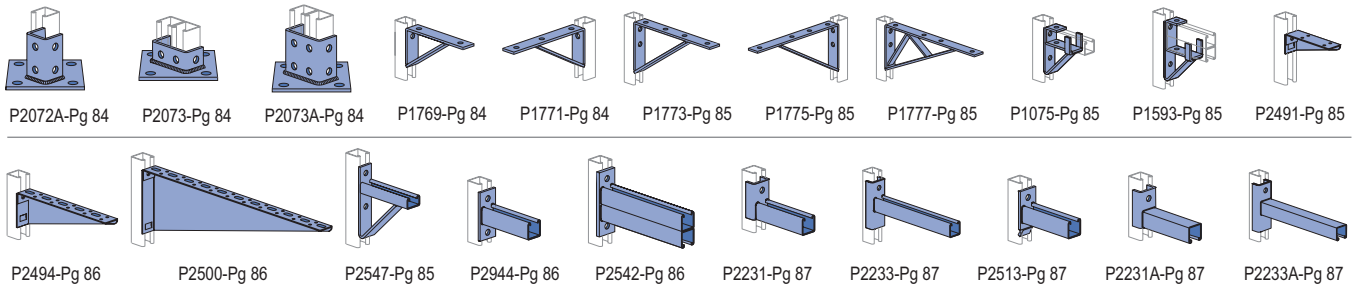

Beam Clamps

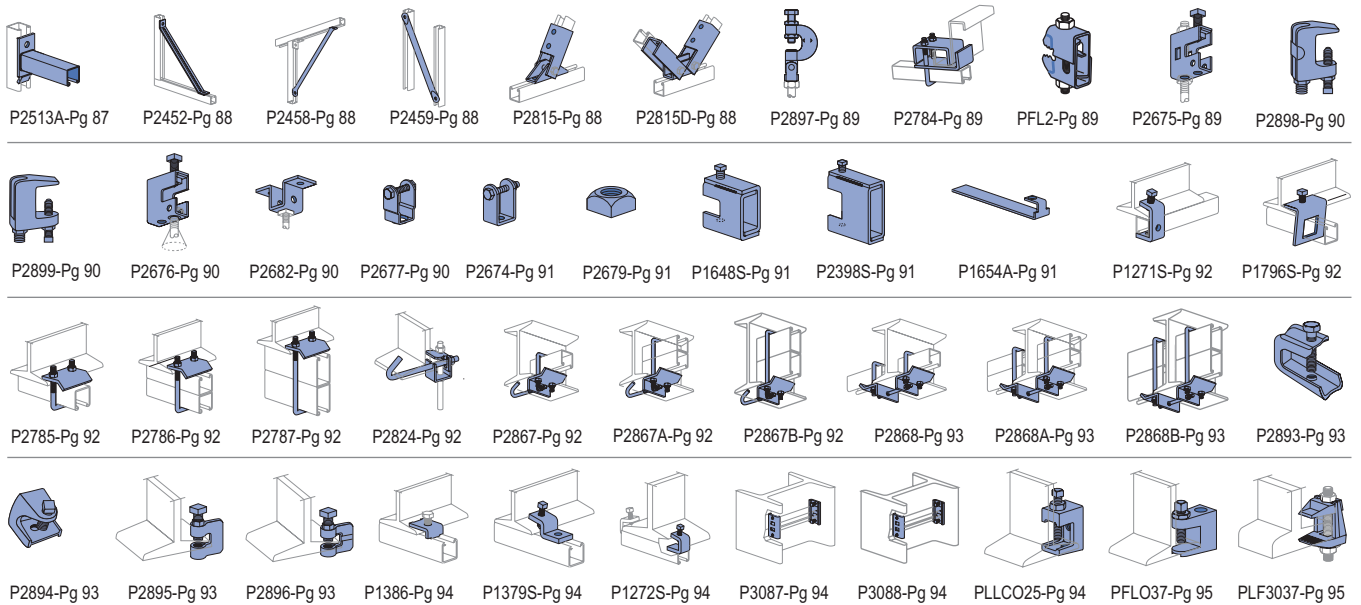

Trolley Assemblies

Special Applications Fittings

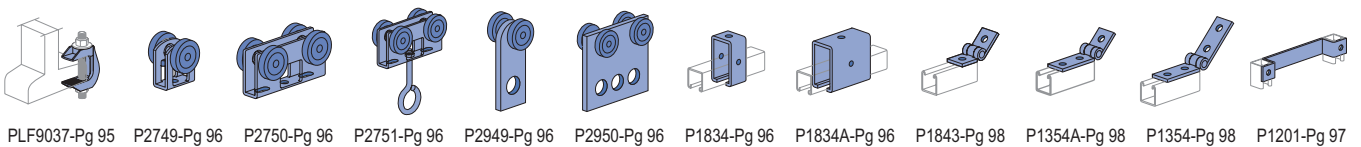

Seismic Retrofit Fittings

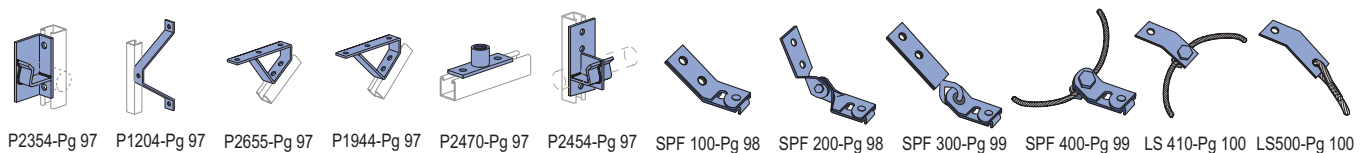



DESIGN LOAD DATA FOR TYPICAL UNISTRUT CHANNEL CONNECTIONS

90° Fittings (When used in position shown)

| Load – P1026 | | Channel Thickness | | |
|--------------|-----|-------------------|--------|--------|
| | | 12 ga. | 14 ga. | 16 ga. |
| | Lbs | 1,500 | 1,000 | 750 |
| | kN | 6.67 | 4.45 | 3.34 |

| Load – P2484 | | Channel Thickness | | |
|--------------|-----|-------------------|--------|--------|
| | | 12 ga. | 14 ga. | 16 ga. |
| | Lbs | 3,000 | 2,000 | 1,500 |
| | kN | 13.34 | 8.90 | 6.67 |

| Load – P1026 | | Channel Thickness | | |
|--------------|-----|-------------------|--------|--------|
| | | 12 ga. | 14 ga. | 16 ga. |
| | Lbs | 1,000 | 650 | 500 |
| | kN | 4.45 | 2.89 | 2.22 |

| Load – P1068 | | Channel Thickness | | |
|--------------|-----|-------------------|--------|--------|
| | | 12 ga. | 14 ga. | 16 ga. |
| | Lbs | 500 | 500 | 500 |
| | kN | 2.22 | 2.22 | 2.22 |

| Load – P1325, P2235 | | Channel Thickness | | |
|---------------------|-----|-------------------|--------|--------|
| | | 12 ga. | 14 ga. | 16 ga. |
| | Lbs | 2,000 | 2,000 | 1,500 |
| | kN | 8.90 | 8.90 | 6.67 |

| Load – P1326 | | Channel Thickness | | |
|--------------|-----|-------------------|--------|--------|
| | | 12 ga. | 14 ga. | 16 ga. |
| | Lbs | 500 | 500 | 500 |
| | kN | 2.22 | 2.22 | 2.22 |

| Load – P1458, P1579 | | Channel Thickness | | |
|---------------------|-----|-------------------|--------|--------|
| | | 12 ga. | 14 ga. | 16 ga. |
| | Lbs | 1,500 | 1,000 | 1,000 |
| | kN | 6.67 | 4.45 | 4.45 |

| Load – P1346 | | Channel Thickness | | |
|--------------|-----|-------------------|--------|--------|
| | | 12 ga. | 14 ga. | 16 ga. |
| | Lbs | 1,200 | 1,200 | 1,000 |
| | kN | 5.34 | 5.34 | 4.45 |

| Load – P1346 | | Channel Thickness | | |
|--------------|-----|-------------------|--------|--------|
| | | 12 ga. | 14 ga. | 16 ga. |
| | Lbs | 2,000 | 1,500 | 900 |
| | kN | 8.90 | 6.67 | 4.00 |

| Load – P1065 | | Channel Thickness | | |
|--------------|-----|-------------------|--------|--------|
| | | 12 ga. | 14 ga. | 16 ga. |
| | Lbs | 1,000 | 800 | 600 |
| | kN | 4.45 | 3.56 | 2.67 |

- Note:
- (1) Both ends of beams supported.
 - (2) Load data is based on P1010 nut and 1/2" bolt.
 - (3) Safety factor = 2 1/2 based on ultimate strength of connection.

1 1/2" Channel
 Teleslur System
 Nuts & Hardware
 General Fittings
 Pipe/Conduit Supports
 Electrical Fittings
 Concrete Inserts
 1 1/4" Framing System
 1 3/16" Framing System
 Fiberglass System
 Special Metals
 PrimeAngle System
 Product Index

P1062, P1063, P1064, P1964, P2471, P2490

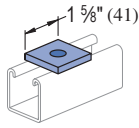

| Part No. | Bolt Size | Hole Size | Wt/100 pcs Lbs (kg) |
|----------|-----------|-----------|---------------------|
| P1062 | 5/16" | 1 1/2" | 18 (8.2) |
| P1063 | 3/8" | 7/16" | 18 (8.2) |
| P1064 | 1/2" | 9/16" | 17 (7.7) |
| P1964 | 5/8" | 1 1/16" | 16 (7.3) |
| P2471 | 3/4" | 1 3/16" | 15 (6.8) |
| P2490 | 7/8" | 1 5/16" | 14 (6.4) |

P1959, P1960, P1961

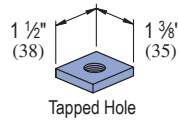

| Part Number | U.S. Std. Thd Size | Wt/100 pcs Lbs (kg) |
|-------------|--------------------|---------------------|
| P1959 | 3/8" - 16 | 21 (9.5) |
| P1960 | 1/2" - 13 | 20 (9.1) |
| P1961 | 5/8" - 11 | 19 (8.6) |

Material: 3/8" (9.5 mm) thick

P2862, 2863, 2864

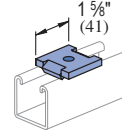

| Part Number | Bolt Size | Hole Size | Wt/100 pcs Lbs (kg) |
|-------------|-----------|-----------|---------------------|
| P2862 | 5/16" | 1 1/32" | 18 (8.2) |
| P2863 | 3/8" | 7/16" | 18 (8.2) |
| P2864 | 1/2" | 9/16" | 17 (7.7) |

P1065

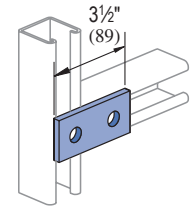

Wt/100 pcs: 38 Lbs (17.2 kg)

P1924

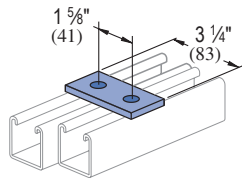

Wt/100 pcs: 35 Lbs (15.9 kg)

P2325

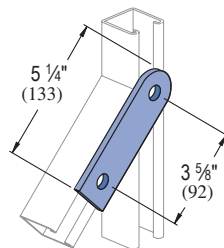

Wt/100 pcs: 55 Lbs (24.9 kg)

P2324

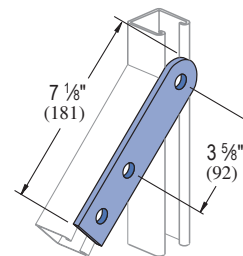

Wt/100 pcs: 75 Lbs (34.0 kg)

P1066

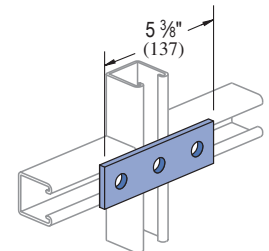

Wt/100 pcs: 56 Lbs (25.4 kg)

P1925

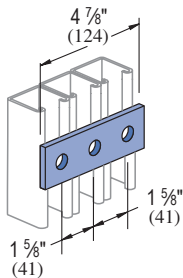

Wt/100 pcs: 50 Lbs (22.7 kg)

P1067

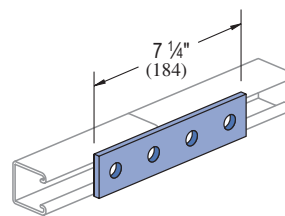

Wt/100 pcs: 78 Lbs (35.4 kg)

P2079

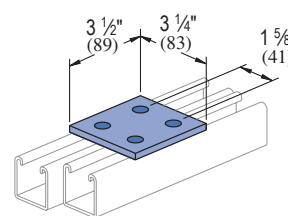

Wt/100 pcs: 73 Lbs (33.1 kg)

P1941

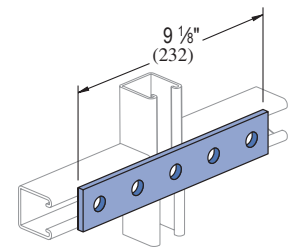

Wt/100 pcs: 94 Lbs (42.6 kg)

P1036

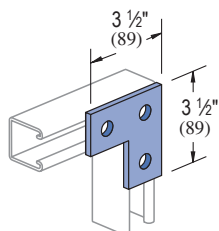

Wt/100 pcs: 58 Lbs (26.3 kg)

P1380 A

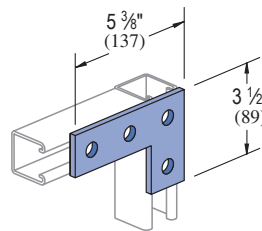

Wt/100 pcs: 80 Lbs (36.3 kg)

P1334

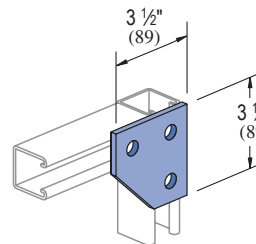

Wt/100 pcs: 70 Lbs (31.8 kg)

P1380

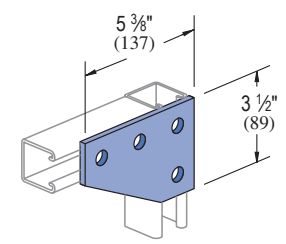

Wt/100 pcs: 105 Lbs (47.6 kg)

Standard Dimensions for 1 5/8" (41mm) width series channel fittings (Unless Otherwise Shown on Drawing)

Hole Diameter: 9/16" (14mm); Hole Spacing - From End: 1 3/16" (21mm); Hole Spacing - On Center: 1 7/8" (48mm); Width: 1 5/8" (41mm); Thickness: 1/4" (6mm)



P1873

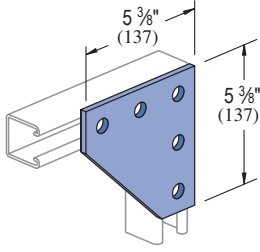

Wt/100 pcs: 150 Lbs (68.0 kg)

P1031

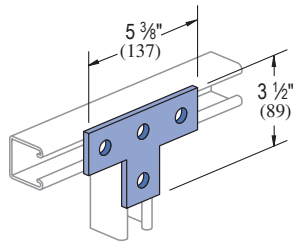

Wt/100 pcs: 80 Lbs (36.3 kg)

P1028

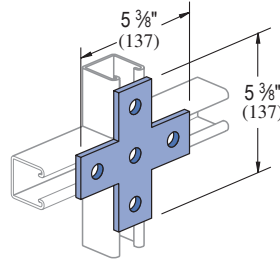

Wt/100 pcs: 105 Lbs (47.6 kg)

P1356

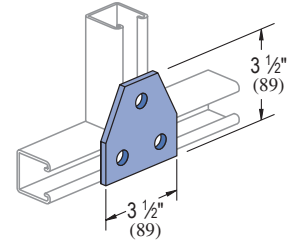

Wt/100 pcs: 70 Lbs (31.8 kg)

P1358

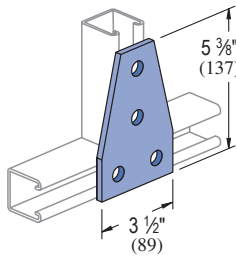

Wt/100 pcs: 105 Lbs (47.6 kg)

P1726

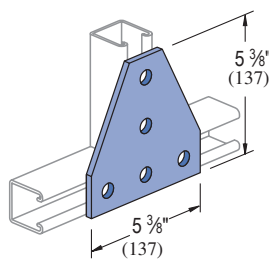

Wt/100 pcs: 148 Lbs (67.1 kg)

P1953

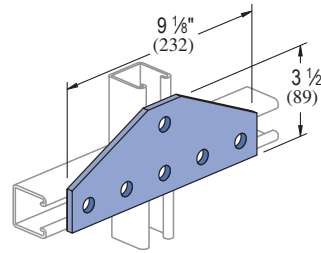

Wt/100 pcs: 176 Lbs (79.8 kg)

P1950

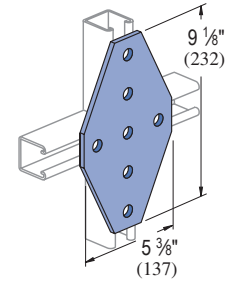

Wt/100 pcs: 240 Lbs (108.9 kg)

P1962

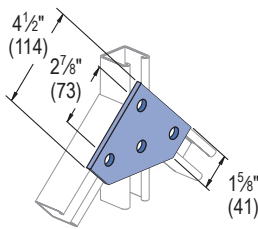

Wt/100 pcs: 112 Lbs (50.8 kg)

P2626

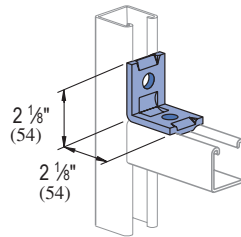

Wt/100 pcs: 40 Lbs (18.1 kg)

P1026

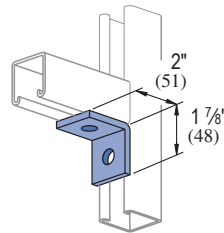

Wt/100 pcs: 38 Lbs (17.2 kg)

P1723

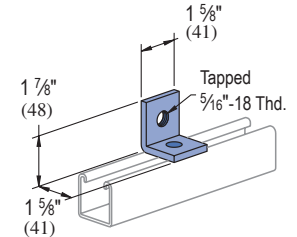

Wt/100 pcs: 34 Lbs (15.4 kg)

P1068

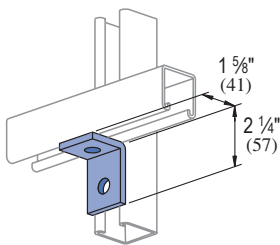

Wt/100 pcs: 38 Lbs (17.2 kg)

P1281, P1282, P1283

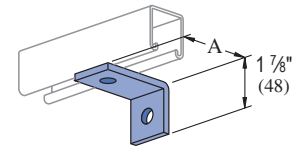

| Part Number | "A" In (mm) | Wt/100 pcs Lbs (kg) |
|-------------|-------------|---------------------|
| P1281 | 3 | 49 |
| P1282 | 76 | 22.2 |
| P1282 | 3 1/2 | 54 |
| P1282 | 89 | 24.5 |
| P1283 | 4 | 61 |
| P1283 | 102 | 27.7 |

P1315

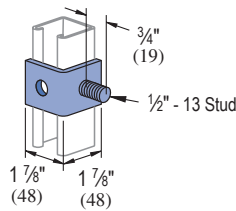

Wt/100 pcs: 45 Lbs (20.4 kg)

P1458

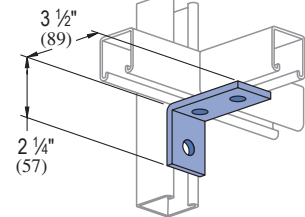

Wt/100 pcs: 58 Lbs (26.3 kg)

Standard Dimensions for 1 5/8" (41mm) width series channel fittings (Unless Otherwise Shown on Drawing)

Hole Diameter: 9/16" (14mm); Hole Spacing - From End: 1 3/16" (21mm); Hole Spacing - On Center: 1 7/8" (48mm); Width: 1 5/8" (41mm); Thickness: 1/4" (6mm)

P1538A THRU P1538D

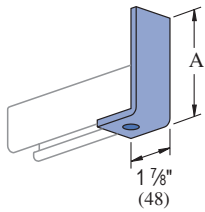

| Part Number | "A" In (mm) | Wt/100 pcs Lbs (kg) |
|-------------|--------------|---------------------|
| P1538A | 3 3/8 98 | 61 27.7 |
| P1538B | 5 7/8 149 | 84 38.1 |
| P1538C | 7 7/8 200 | 107 48.5 |
| P1538D | 9 7/8 251 | 130 59.0 |

P1498, P1499

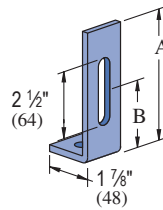

| Part Number | "A" In (mm) | "B" In (mm) | Wt/100 pcs Lbs (kg) |
|-------------|--------------|--------------|---------------------|
| P1498 | 4 7/8 124 | 2 1/2 64 | 65 29.5 |
| P1499 | 6 7/8 175 | 4 1/2 114 | 85 38.6 |

P1750

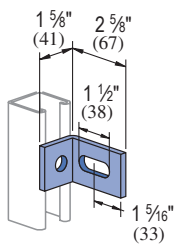

Wt/100 pcs: 38 Lbs (17.2 kg)

P1747

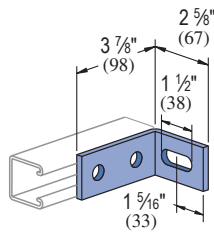

Wt/100 pcs: 66 Lbs (29.9 kg)

P1326

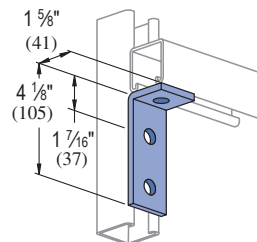

Wt/100 pcs: 58 Lbs (26.3 kg)

P1821

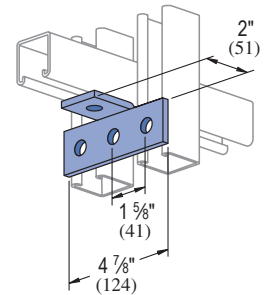

Wt/100 pcs: 71 Lbs (32.2 kg)

P1346

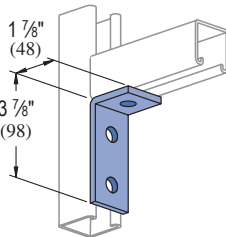

Wt/100 pcs: 58 Lbs (26.3 kg)

P1325

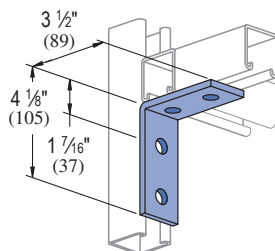

Wt/100 pcs: 78 Lbs (35.4 kg)

P1822

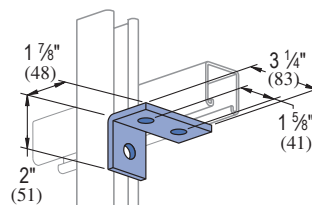

Wt/100 pcs: 55 Lbs (24.9 kg)

P1823

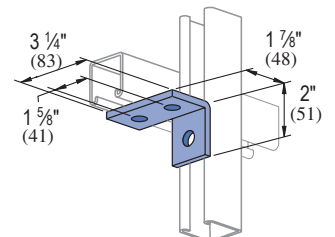

Wt/100 pcs: 55 Lbs (24.9 kg)

P1033

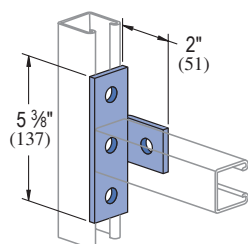

Wt/100 pcs: 80 Lbs (36.3 kg)

P1037

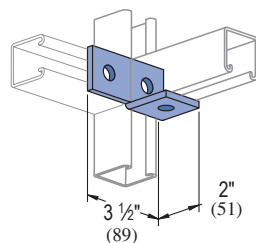

Wt/100 pcs: 58 Lbs (26.3 kg)

P1038

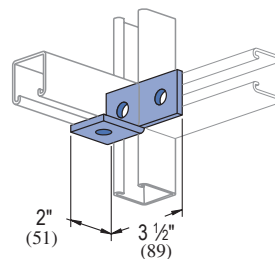

Wt/100 pcs: 58 Lbs (26.3 kg)

P1034

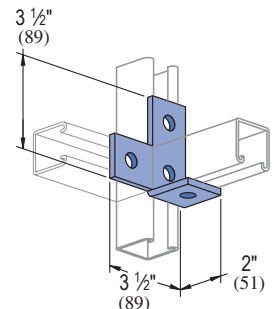

Wt/100 pcs: 80 Lbs (36.3 kg)

Standard Dimensions for 1 5/8" (41mm) width series channel fittings (Unless Otherwise Shown on Drawing)

Hole Diameter: 9/16" (14mm); Hole Spacing - From End: 13/16" (21mm); Hole Spacing - On Center: 1 7/8" (48mm); Width: 1 5/8" (41mm); Thickness: 1/4" (6mm)



P1029

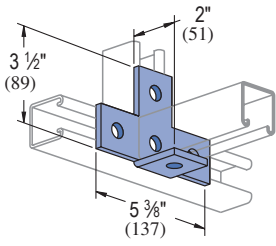

Wt/100 pcs: 105 Lbs (47.6 kg)

P1035

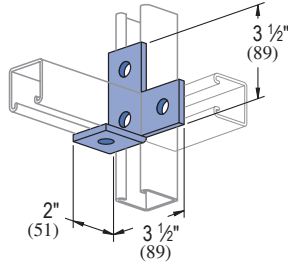

Wt/100 pcs: 80 Lbs (36.3 kg)

P1290

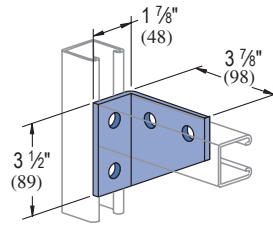

Wt/100 pcs: 101 Lbs (45.8 kg)

P1291

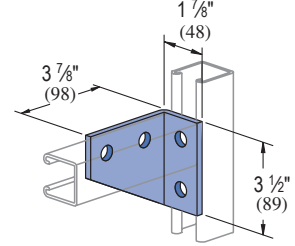

Wt/100 pcs: 101 Lbs (45.8 kg)

P1357

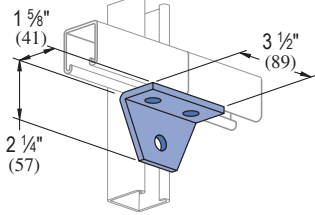

Wt/100 pcs: 70 Lbs (31.8 kg)

P1359

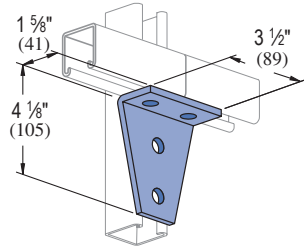

Wt/100 pcs: 105 Lbs (47.6 kg)

P1381

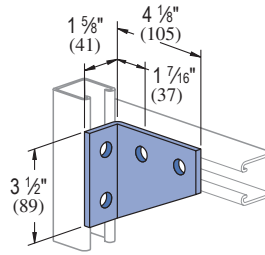

Wt/100 pcs: 105 Lbs (47.6 kg)

P1382

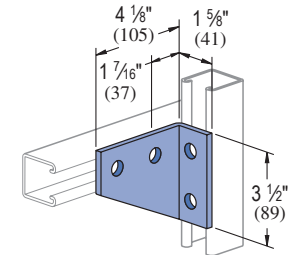

Wt/100 pcs: 105 Lbs (47.6 kg)

P1934

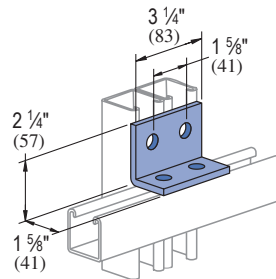

Wt/100 pcs: 75 Lbs (34.0 kg)

P1713

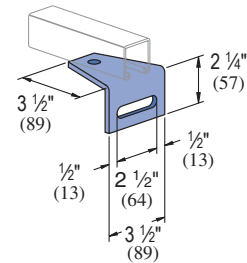

Wt/100 pcs: 97 Lbs (44.0 kg)

P1579

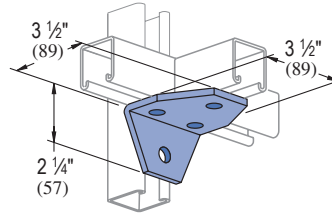

Wt/100 pcs: 103 Lbs (46.7 kg)

P1727

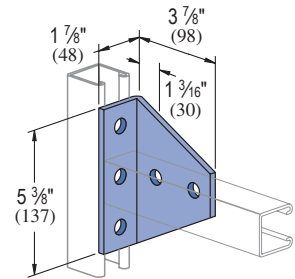

Wt/100 pcs: 154 Lbs (69.9 kg)

P1728

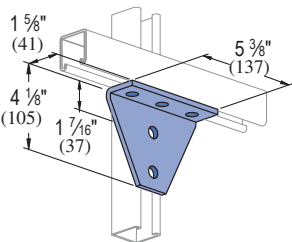

Wt/100 pcs: 154 Lbs (69.9 kg)

P2235

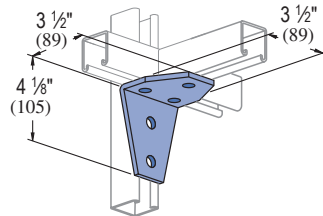

Wt/100 pcs: 135 Lbs (61.2 kg)

P1956

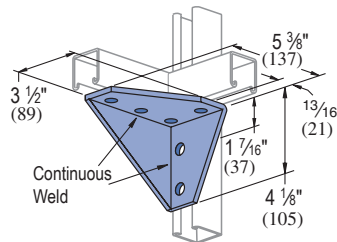

Wt/100 pcs: 230 Lbs (104.3 kg)

P1957

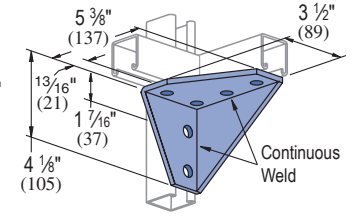

Wt/100 pcs: 230 Lbs (104.3 kg)

Standard Dimensions for 1 5/8" (41mm) width series channel fittings (Unless Otherwise Shown on Drawing)

Hole Diameter: 9/16" (14mm); Hole Spacing - From End: 13/16" (21mm); Hole Spacing - On Center: 1 7/8" (48mm); Width: 1 5/8" (41mm); Thickness: 1/4" (6mm)

1 5/8" Channel
 Telestrut System
 Nuts & Hardware
 General Fittings
 Pipe/Conduit Supports
 Electrical Fittings
 Concrete Inserts
 1 1/4" Framing System
 1 3/16" Framing System
 Fiberglass System
 Special Metals
 PrimeAngle System
 Product Index

P2484

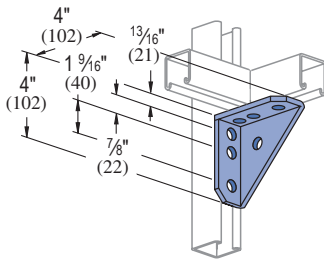

Wt/100 pcs: 134 Lbs (60.8 kg)

P2484W

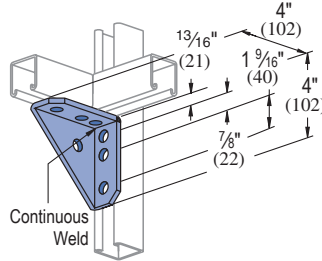

Wt/100 pcs: 134 Lbs (60.8 kg)

P1130, P1131

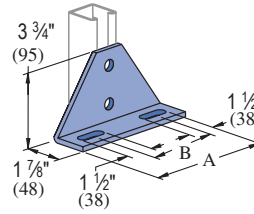

| Part Number | "A" In (mm) | "B" In (mm) | Wt/100 pcs Lbs (kg) |
|-------------|--------------------------------------|-------------|---------------------|
| P1130 | 6 ⁵ / ₈ 168 | 4 102 | 190 86.2 |
| P1131 | 8 ⁵ / ₈ 219 | 6 152 | 242 109.8 |

P1546, P2094 THRU P2100

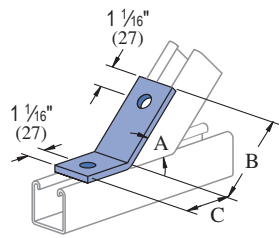

| Part No. | "A" Degree (rad) | "B" In (mm) | "C" In (mm) |
|----------|--|---------------------------------------|---------------------------------------|
| P2094 | 82 ¹ / ₂ ° 1.44 | 3 ³ / ₁₆ 91 | 1 ¹¹ / ₁₆ 43 |
| P2095 | 75° 1.31 | 3 ³ / ₁₆ 91 | 1 ¹¹ / ₁₆ 43 |
| P2096 | 67 ¹ / ₂ ° 1.18 | 3 ¹ / ₂ 89 | 1 ³ / ₄ 44 |
| P2097 | 60° 1.05 | 3 ³ / ₈ 86 | 1 ¹ / ₂ 48 |
| P2098 | 52 ¹ / ₂ ° 0.92 | 3 ¹ / ₄ 83 | 2 ¹ / ₁₆ 52 |
| P1546 | 45° 0.79 | 3 76 | 2 ⁵ / ₁₆ 59 |
| P2099 | 37 ¹ / ₂ ° 0.65 | 3 ¹ / ₂ 89 | 1 ¹³ / ₁₆ 46 |
| P2100 | 37 ¹ / ₂ ° 0.65 | 2 ¹¹ / ₁₆ 68 | 2 ⁵ / ₈ 67 |

Wt/100 pcs: 58 Lbs (26.3 kg)

P2101 THRU P2104

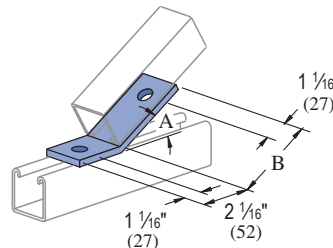

| Part No. | "A" Degree (rad) | "B" In (mm) |
|----------|--|--------------------------------------|
| P2101 | 30° 0.52 | 3 ¹ / ₄ 83 |
| P2102 | 22 ¹ / ₂ ° 0.39 | 3 ⁵ / ₁₆ 84 |
| P2103 | 15° 0.26 | 3 ⁵ / ₁₆ 84 |
| P2104 | 7 ¹ / ₂ ° 0.13 | 3 ⁵ / ₁₆ 84 |

Wt/100 pcs: 58 Lbs (26.3 kg)

P1186, P2105 THRU P2110

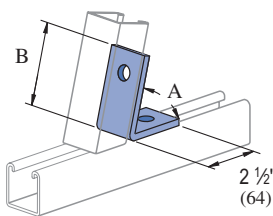

| Part Number | "A" Degree (rad) | "B" In (mm) |
|-------------|--|--------------------------------------|
| P2105 | 82 ¹ / ₂ ° 1.44 | 3 ³ / ₁₆ 81 |
| P2106 | 75° 1.31 | 3 ³ / ₁₆ 81 |
| P2107 | 67 ¹ / ₂ ° 1.18 | 3 ¹ / ₈ 79 |
| P2108 | 60° 1.05 | 3 ¹ / ₈ 79 |
| P2109 | 52 ¹ / ₂ ° 0.92 | 3 ¹ / ₁₆ 78 |
| P1186 | 45° 0.79 | 3 ¹ / ₈ 79 |
| P2110 | 37 ¹ / ₂ ° 0.65 | 3 76 |

Wt/100 pcs: 58 Lbs (26.3 kg)

P2260 THRU P2270

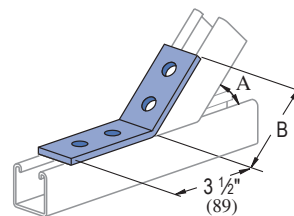

| Part Number | "A" Degree (rad) | "B" In (mm) |
|-------------|--|---------------------------------------|
| P2270 | 82 ¹ / ₂ ° 1.44 | 3 ⁵ / ₈ 91 |
| P2269 | 75° 1.31 | 3 ⁵ / ₈ 91 |
| P2268 | 67 ¹ / ₂ ° 1.18 | 3 ⁵ / ₈ 91 |
| P2267 | 60° 1.05 | 3 ¹¹ / ₁₆ 94 |
| P2266 | 52 ¹ / ₂ ° 0.92 | 3 ¹¹ / ₁₆ 94 |
| P2265 | 45° 0.79 | 3 ¹¹ / ₁₆ 94 |
| P2264 | 37 ¹ / ₂ ° 0.65 | 3 ¹¹ / ₁₆ 94 |
| P2263 | 30° 0.52 | 3 ¹¹ / ₁₆ 94 |
| P2262 | 22 ¹ / ₂ ° 0.39 | 3 ³ / ₄ 95 |
| P2261 | 15° 0.26 | 3 ³ / ₄ 95 |
| P2260 | 7 ¹ / ₂ ° 0.13 | 3 ³ / ₄ 95 |

Wt/100 pcs: 78 Lbs (35.4 kg)

Standard Dimensions for 1⁵/₈" (41mm) width series channel fittings (Unless Otherwise Shown on Drawing)

Hole Diameter: ⁹/₁₆" (14mm); Hole Spacing - From End: ¹³/₁₆" (21mm); Hole Spacing - On Center: 1⁷/₈" (48mm); Width: 1⁵/₈" (41mm); Thickness: ¹/₄" (6mm)



P1045

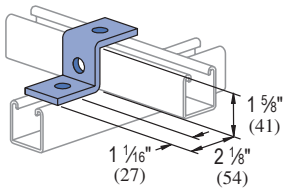

Wt/100 pcs: 55 Lbs (24.9 kg)

P1347

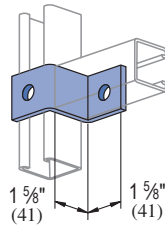

Wt/100 pcs: 55 Lbs (24.9 kg)

P1453

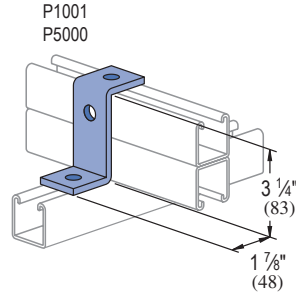

Wt/100 pcs: 70 Lbs (31.8 kg)

P1454

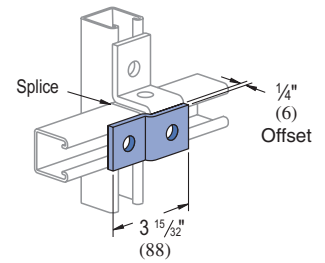

Wt/100 pcs: 38 Lbs (17.2 kg)

P1479A THRU P1479E

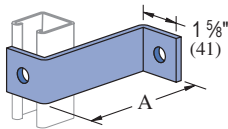

| Part Number | "A" In (mm) | Wt/100 pcs Lbs (kg) |
|-------------|-------------|---------------------|
| P1479A | 4 (102) | 81 (36.7) |
| P1479B | 5 (127) | 92 (41.7) |
| P1479C | 6 (152) | 104 (47.2) |
| P1479D | 7 (178) | 115 (52.2) |
| P1479E | 8 (203) | 127 (57.6) |

P1730

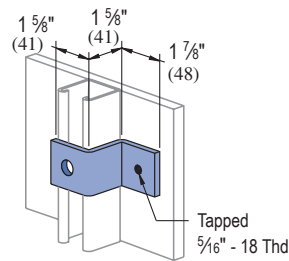

Wt/100 pcs: 54 Lbs (24.5 kg)

P1734

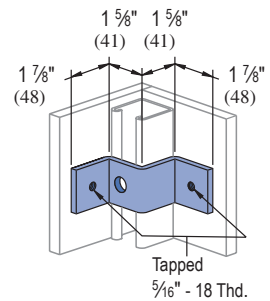

Wt/100 pcs: 70 Lbs (31.8 kg)

P1736

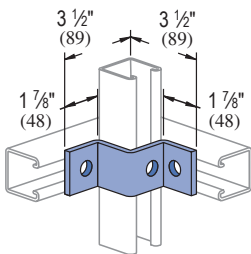

Wt/100 pcs: 70 Lbs (31.8 Kg)

P2360

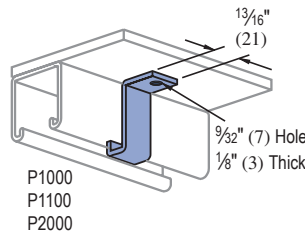

Wt/100 pcs: 9 Lbs (4.1 kg)

P5560

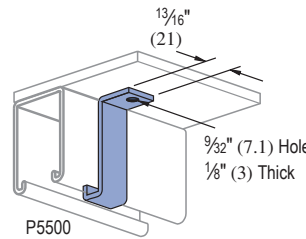

Wt/100 pcs: 11 Lbs (5.0 kg)

P3045

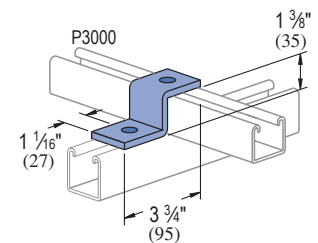

Wt/100 pcs: 53 Lbs (24.0 kg)

P3345

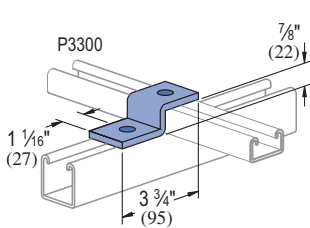

Wt/100 pcs: 47 Lbs (21.3 kg)

P4045

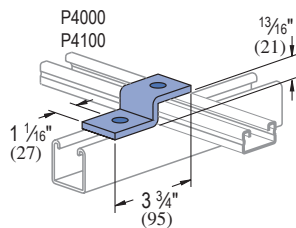

Wt/100 pcs: 47 Lbs (21.3 kg)

P5545

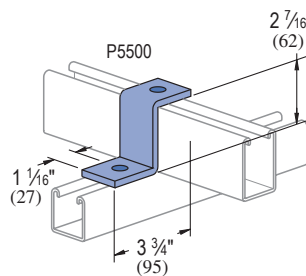

Wt/100 pcs: 67 Lbs (30.4 kg)

P2469

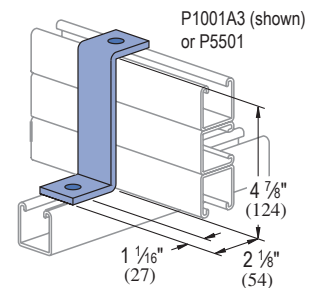

Wt/100 pcs: 93 Lbs (42.2 kg)

Standard Dimensions for 1 5/8" (41mm) width series channel fittings (Unless Otherwise Shown on Drawing)

Hole Diameter: 9/16" (14mm); Hole Spacing - From End: 13/16" (21mm); Hole Spacing - On Center: 1 7/8" (48mm); Width: 1 5/8" (41mm); Thickness: 1/4" (6mm)

1 5/8" Channel
 Telestrut System
 Nuts & Hardware
 General Fittings
 Pipe/Conduit Supports
 Electrical Fittings
 Concrete Inserts
 1 1/4" Framing System
 1 3/16" Framing System
 Fiberglass System
 Special Metals
 PrimeAngle System
 Product Index

P2800

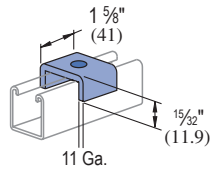

| Part Number | Bolt Size In | Wt/100 pcs Lbs (kg) |
|-------------|--------------|---------------------|
| P2800-25 | 1/4" | 14 6.4 |
| P2800-37 | 3/8" | 14 6.4 |
| P2800-50 | 1/2" | 13 5.9 |
| P2800-62 | 5/8" | 13 5.9 |
| P2800-75 | 3/4" | 13 5.9 |

P1363A THRU P1363E

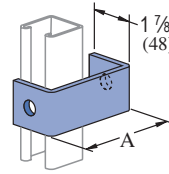

| Part Number | "A" In (mm) | Wt/100 pcs Lbs (kg) |
|-------------|-------------|---------------------|
| P1363A | 4 | 78 |
| P1363B | 5 | 89 |
| P1363C | 6 | 101 |
| P1363D | 7 | 112 |
| P1363E | 8 | 124 |

P1320

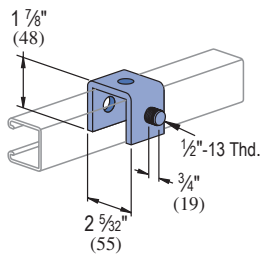

Wt/100 pcs: 63 Lbs (28.6 kg)

P1376

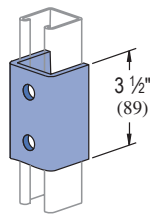

Wt/100 pcs: 128 Lbs (58.1 kg)

P4376

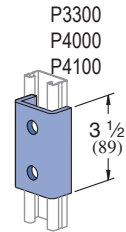

Wt/100 pcs: 85 Lbs (38.6 kg)

P1376A

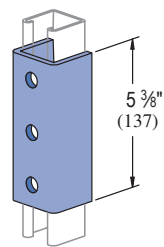

Wt/100 pcs: 197 Lbs (89.4 kg)

P4376A

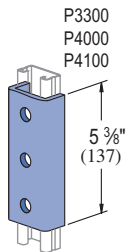

Wt/100 pcs: 130 Lbs (59.0 kg)

P1377, P4377, P5077, P5577

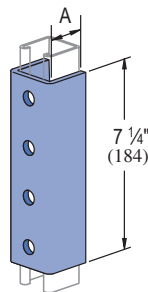

| Part Number | For Use With | Wt/100 pcs Lbs (kg) |
|-------------|---------------------|---------------------|
| P1377 | P1000, P1100, P2000 | 265 120 |
| P4377 | P3300, P4000, P4100 | 176 80 |
| P5077 | P5000 | 390 177 |
| P5577 | P5500 | 310 141 |

P1047

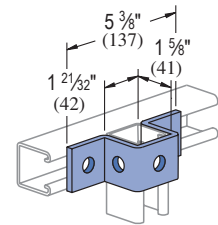

Wt/100 pcs: 88 Lbs (39.9 kg)

P3047

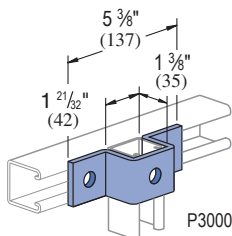

Wt/100 pcs: 84 Lbs (38.1 kg)

P4047

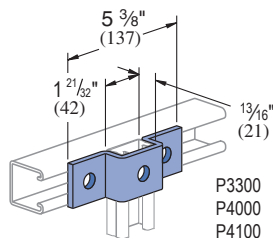

Wt/100 pcs: 71 Lbs (32.2 kg)

P1455

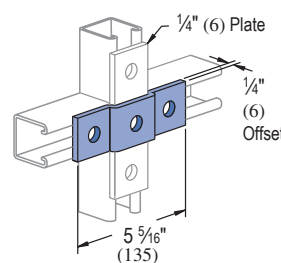

Wt/100 pcs: 58 Lbs (26.3 kg)

P5547

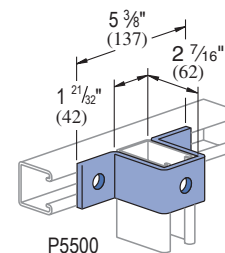

Wt/100 pcs: 108 Lbs (49.0 kg)

Standard Dimensions for 1 5/8" (41mm) width series channel fittings (Unless Otherwise Shown on Drawing)

Hole Diameter: 9/16" (14mm); Hole Spacing - From End: 1 3/16" (21mm); Hole Spacing - On Center: 1 7/8" (48mm); Width: 1 5/8" (41mm); Thickness: 1/4" (6mm)



P1383

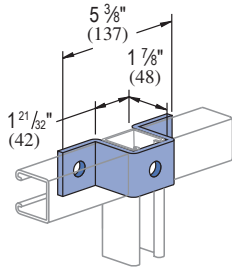

Wt/100 pcs: 95 Lbs (43.1 kg)

P1732

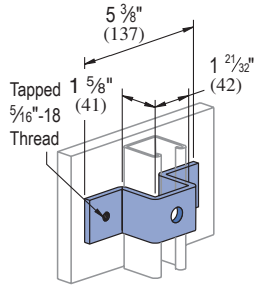

Wt/100 pcs: 88 Lbs (39.9 kg)

P2237

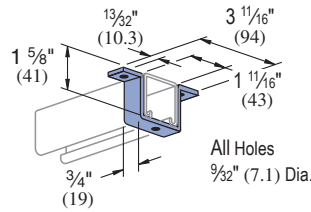

Material: 1/8" (3.2) thick.

Wt/100 pcs: 18 Lbs (8.2 kg)

P5543

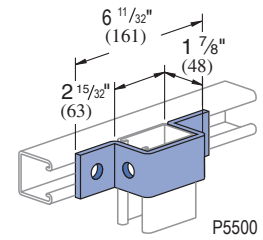

P5500

Wt/100 pcs: 97 Lbs (44.0 kg)

P1048, P1049, P1050

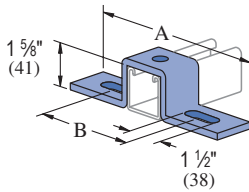

| Part Number | "A" In (mm) | "B" In (mm) | Wt/100 pcs Lbs (kg) |
|-------------|---------------|--------------|---------------------|
| P1048 | 7 1/4 184 | 4 1/8 105 | 105 47.6 |
| P1049 | 8 1/2 216 | 5 3/8 137 | 120 54.4 |
| P1050 | 10 3/8 264 | 7 1/4 184 | 130 59.0 |

P1043A

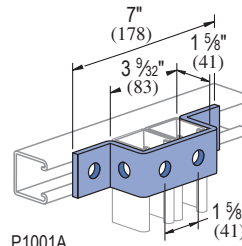

P1001A

Wt/100 pcs: 105 Lbs (47.6 kg)

P1737

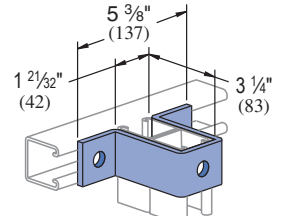

P1001 (shown), P1101, P2001, P4004 or P5000

Wt/100 pcs: 128 Lbs (58.1 kg)

P2473

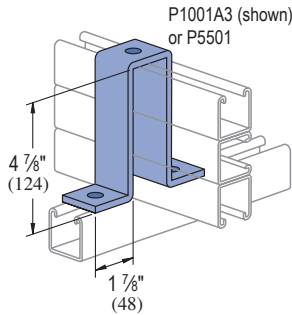

Wt/100 pcs: 197 Lbs (89.4 kg)

P4043

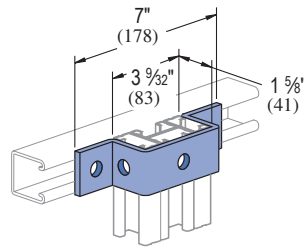

P4004 (shown), P1001, P1101, P2001, or P5000

Wt/100 pcs: 106 Lbs (48.1 kg)

P1044

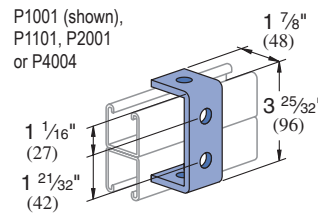

Wt/100 pcs: 70 Lbs (31.8 kg)

P1973

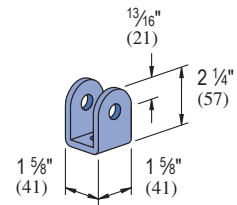

Wt/100 pcs: 53 Lbs (24.0 kg)

P2326

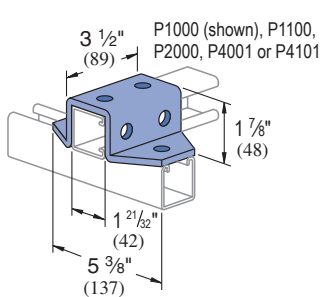

Wt/100 pcs: 171 Lbs (77.6 kg)

P2328

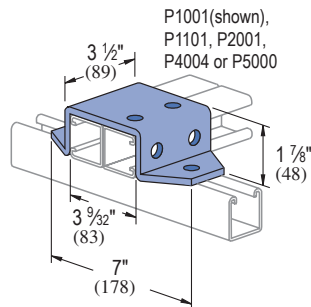

Wt/100 pcs: 209 Lbs (94.8 kg)

P2329

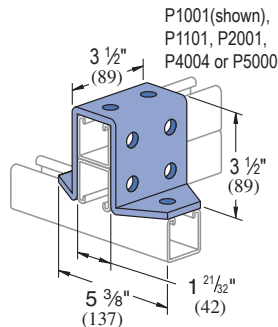

Wt/100 pcs: 257 Lbs (116.6 kg)

P1046A

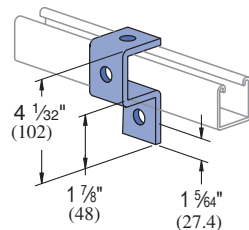

Wt/100 pcs: 76 Lbs (34.5 kg)

Standard Dimensions for 1 5/8" (41mm) width series channel fittings (Unless Otherwise Shown on Drawing)

Hole Diameter: 9/16" (14mm); Hole Spacing - From End: 1 3/16" (21mm); Hole Spacing - On Center: 1 7/8" (48mm); Width: 1 5/8" (41mm); Thickness: 1/4" (6mm)

P2341 R-L

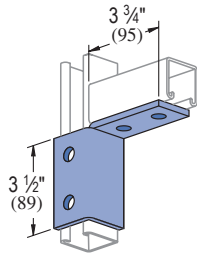

R - As shown
L - Opposite hand

Wt/100 pcs: 60 Lbs (27.2 kg)

P2224

P2472 R-L

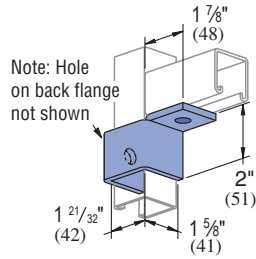

R - As shown
L - Opposite hand

Wt/100 pcs: 75 Lbs (34.0 kg)

P2225

P2343 R-L

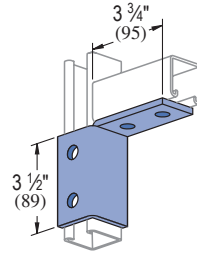

R - As shown
L - Opposite hand

Wt/100 pcs: 119 Lbs (54.0 kg)

P2227

P2223

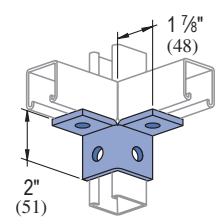

Wt/100 pcs: 76 Lbs (34.5 kg)

P2228

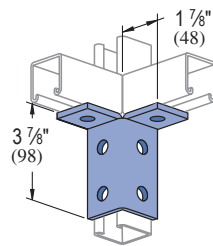

Wt/100 pcs: 115 Lbs (52.2 kg)

P2229

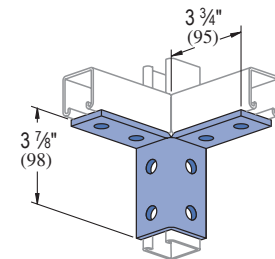

Wt/100 pcs: 155 Lbs (70.3 kg)

P2345

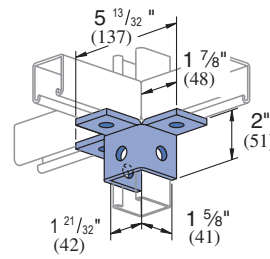

Wt/100 pcs: 113 Lbs (51.3 kg)

P2346

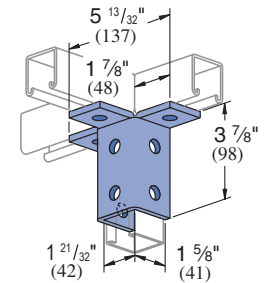

Wt/100 pcs: 177 Lbs (80.3 kg)

P2347

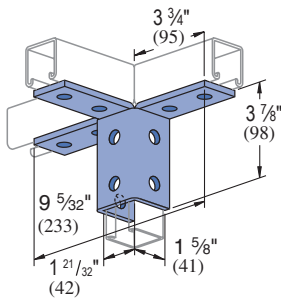

Wt/100 pcs: 230 Lbs (104.3 kg)

P2344 R-L

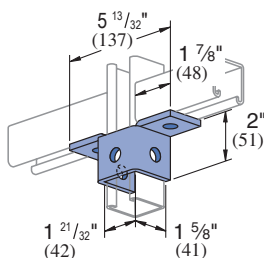

Wt/100 pcs: 93 Lbs (42.2 kg)

P2226

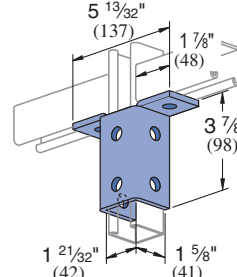

Wt/100 pcs: 150 Lbs (68.0 kg)

P2230

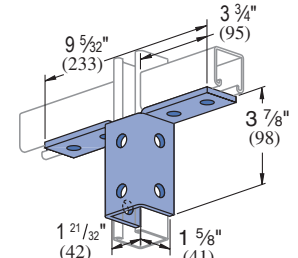

Wt/100 pcs: 193 Lbs (87.5 kg)

P2245

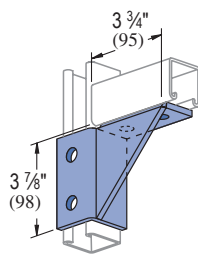

R - As shown
L - Opposite hand

Wt/100 pcs: 176 Lbs (79.8 kg)

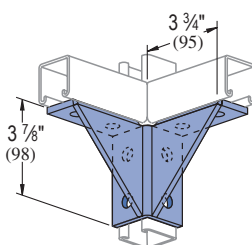

Wt/100 pcs: 217 Lbs (98.4 kg)

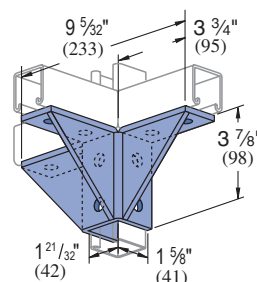

Wt/100 pcs: 310 Lbs (140.6 kg)

Fitting notched for continuous vertical.

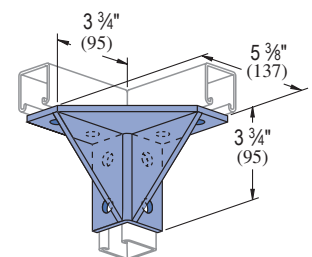

Wt/100 pcs: 315 Lbs (142.9 kg)

Standard Dimensions for 1 5/8" (41mm) width series channel fittings (Unless Otherwise Shown on Drawing)

Hole Diameter: 9/16" (14mm); Hole Spacing - From End: 1 3/16" (21mm); Hole Spacing - On Center: 1 7/8" (48mm); Width: 1 5/8" (41mm); Thickness: 1/4" (6mm)



P2348

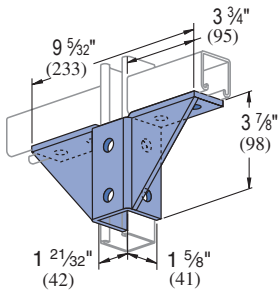

Wt/100 pcs: 274 Lbs (124.3 kg)

P2453

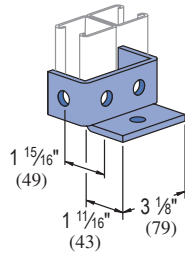

Wt/100 pcs: 116 Lbs (52.6 kg)

P1887

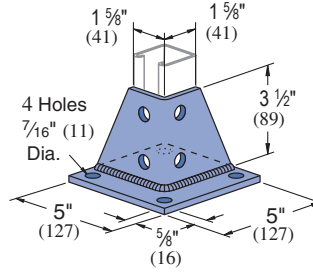

Wt/100 pcs: 297 Lbs (134.8 kg)

P2941, P2942

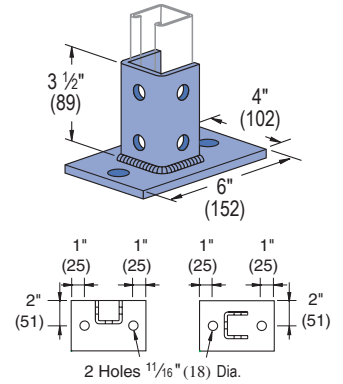

Wt/100 pcs: 358 Lbs (162.4 kg)

P2072, P2072 SQ

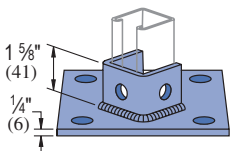

P2072

P2072A, P2072A SQ

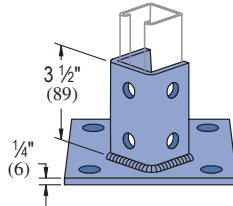

P2072A

P2073, P2073 SQ

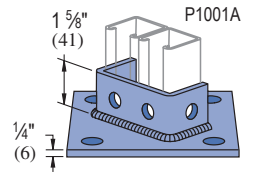

P2073

P2073A, P2073A SQ

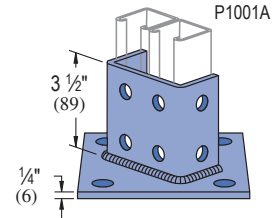

P2073A

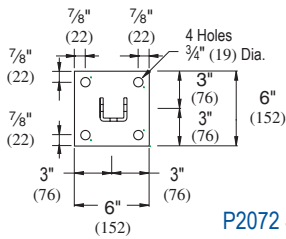
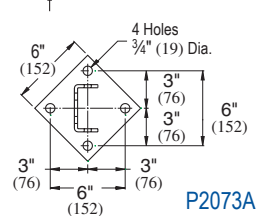
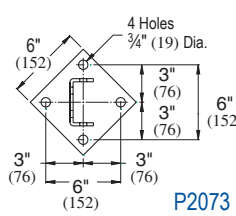
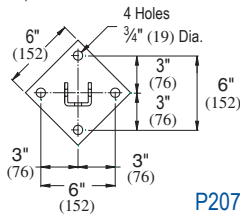
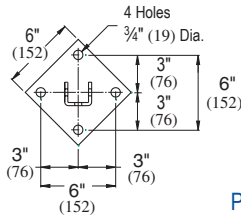

P2072 SQ

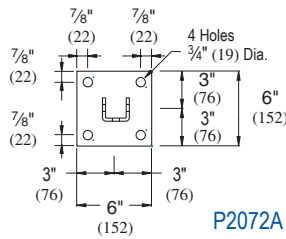

P2072A SQ

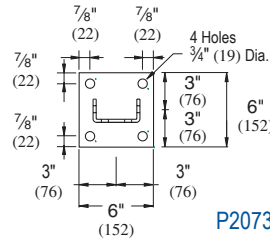

P2073 SQ

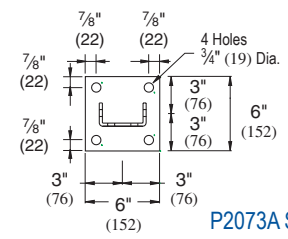

P2073A SQ

Wt/100 pcs: 307 Lbs (139.3 kg)

Wt/100 pcs: 373 Lbs (169.2 kg)

Wt/100 pcs: 325 Lbs (147.4 kg)

Wt/100 pcs: 408 Lbs (185.1 kg)

P1769

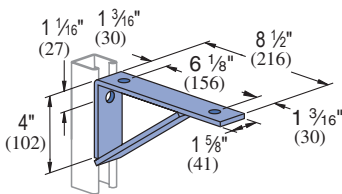

Material: 1/4" (6.4) thick steel.

Wt/100 pcs: 174 Lbs (78.9 kg)

| Part No. | Vertical Channel Gauge | Uniform Design Load | |
|----------|------------------------|---------------------|------|
| | | Lbs | (kN) |
| P1000 | 12 | 800 | 3.56 |
| P1100 | 14 | 600 | 2.67 |
| P2000 | 16 | 400 | 1.78 |

Safety Factor 2 1/2

P1771

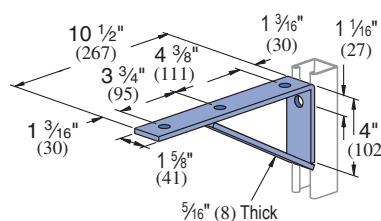

Material: 1/4" (6.4) thick steel.

Wt/100 pcs: 206 Lbs (93.4 kg)

| Part No. | Vertical Channel Gauge | Uniform Design Load | |
|----------|------------------------|---------------------|------|
| | | Lbs | (kN) |
| P1000 | 12 | 800 | 3.56 |
| P1100 | 14 | 600 | 2.67 |
| P2000 | 16 | 400 | 1.78 |

Safety Factor 2 1/2

Standard Dimensions for 1 1/2" (41mm) width series channel fittings (Unless Otherwise Shown on Drawing)

Hole Diameter: 9/16" (14mm); Hole Spacing - From End: 1 3/16" (21mm); Hole Spacing - On Center: 1 7/8" (48mm); Width: 1 5/8" (41mm); Thickness: 1/4" (6mm)

Note : When used for mechanical supports, load capacities of brackets and fittings should be in compliance with the American Standard Code for Pressure Piping.

P1773

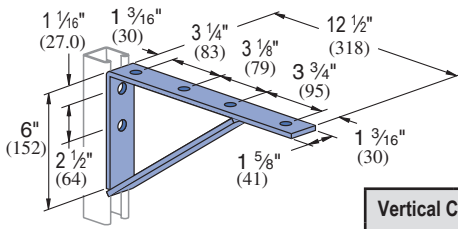

| Part No. | Gauge | Vertical Channel | Uniform Design Load Lbs (kN) |
|----------|-------|------------------|------------------------------|
| P1000 | 12 | 12 | 900 (4.00) |
| P1100 | 14 | 14 | 800 (3.56) |
| P2000 | 16 | 16 | 450 (2.00) |

Material: 1/4" (6.4) thick steel.

Safety Factor 2 1/2

Wt/100 pcs: 264 Lbs (119.7 kg)

P1775

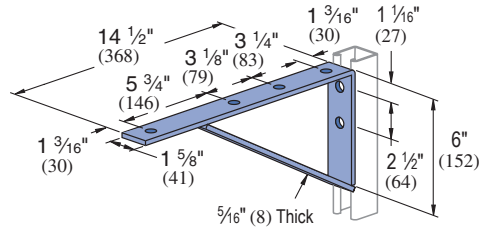

| Part No. | Gauge | Vertical Channel | Uniform Design Load Lbs (kN) |
|----------|-------|------------------|------------------------------|
| P1000 | 12 | 12 | 900 (4.00) |
| P1100 | 14 | 14 | 800 (3.56) |
| P2000 | 16 | 16 | 450 (2.00) |

Material: 1/4" (6.4) thick steel.

Safety Factor 2 1/2

Wt/100 pcs: 295 Lbs (133.8 kg)

P1075

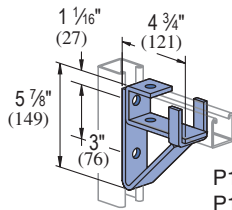

P1000
P1100
P2000
P4001

| Part No. | Gauge | Vertical Channel | Allowable Moment* In-Lbs (N•M) |
|----------|-------|------------------|--------------------------------|
| P1000 | 12 | 12 | 5,100 (576) |
| P1100 | 14 | 14 | 4,400 (497) |
| P2000 | 16 | 16 | 3,200 (362) |

Safety Factor 2 1/2

Material: 1/4" (6.4) thick steel.

Wt/100 pcs: 229 Lbs (103.9 kg)

* Allowable moment for fitting only. Channel may determine overall capacity.

P1593

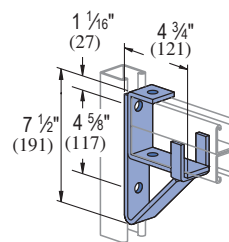

P1001
P1101
P5000
P2001

| Part No. | Gauge | Vertical Channel | Allowable Moment* In-Lbs (N•M) |
|----------|-------|------------------|--------------------------------|
| P1000 | 12 | 12 | 13,000 1,469 |
| P1100 | 14 | 14 | 9,100 1,028 |
| P2000 | 16 | 16 | 6,500 734 |

Safety Factor 2 1/2

Material: 1/4" (6.4) thick steel.

Wt/100 pcs: 272 Lbs (123.4 kg)

* Allowable moment for fitting only. Channel may determine overall capacity.

P1777

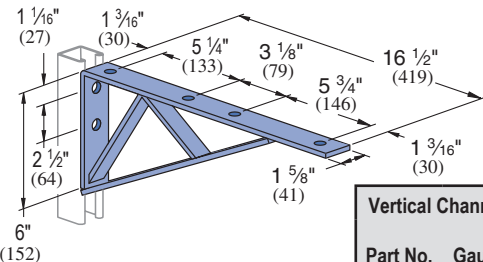

| Part No. | Gauge | Vertical Channel | Uniform Design Load Lbs (kN) |
|----------|-------|------------------|------------------------------|
| P1000 | 12 | 12 | 1,200 (5.34) |
| P1100 | 14 | 14 | 900 (4.00) |
| P2000 | 16 | 16 | 600 (2.67) |

Material: 1/4" (6.4) thick steel.

Safety Factor 2 1/2

Wt/100 pcs: 385 Lbs (174.6 kg)

P2547 THRU P2551

CABLE TRAY BRACKET

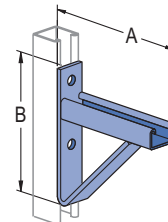

| Part Number | "A" In (mm) | "B" In (mm) | Wt/100 pcs Lbs (kg) | Uniform Load* Lbs (kN) |
|-------------|-------------|-------------|---------------------|------------------------|
| P2547 | 15 | 8 3/4 | 420 | 1,000 |
| | 381 | 222 | 190.5 | 4.45 |
| P2548 | 21 | 8 3/4 | 628 | 1,000 |
| | 533 | 222 | 284.9 | 4.45 |
| P2549 | 27 | 11 1/4 | 860 | 900 |
| | 686 | 286 | 390.1 | 4.00 |
| P2550 | 33 | 11 1/4 | 1010 | 900 |
| | 838 | 286 | 458.1 | 4.00 |
| P2551 | 39 | 16 | 1257 | 800 |
| | 991 | 406 | 683.3 | 3.56 |

P2491 R-L THRU P2493 R-L

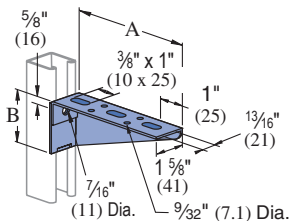

| Part No. | Gauge | Vertical Channel | Uniform Design Load Lbs (kN) |
|----------|-------|------------------|------------------------------|
| P1000 | 12 | 12 | 300 (1.33) |
| P1100 | 14 | 14 | 250 (1.11) |
| P2000 | 16 | 16 | 200 (.89) |

Safety Factor - 2 1/2

| Part Number | Stamped Ident. No. | "A" In (mm) | "B" In (mm) | Wt/100 pcs Lbs (kg) |
|-------------|--------------------|-------------|-------------|---------------------|
| P2491 R-L | 121892 R-L | 6 | 1 15/16 | 67 |
| | | 52 | 49 | 30.4 |
| P2492 R-L | 121893 R-L | 8 | 2 1/16 | 92 |
| | | 203 | 62 | 41.7 |
| P2493 R-L | 121894 R-L | 10 | 2 15/16 | 120 |
| | | 254 | 75 | 54.4 |

R - As shown; L - Opposite hand

Material : 12 Gauge Steel.

Standard Dimensions for 1 1/2" (41mm) width series channel fittings (Unless Otherwise Shown on Drawing)

Hole Diameter: 5/16" (14mm); Hole Spacing - From End: 1 3/16" (21mm); Hole Spacing - On Center: 1 1/8" (48mm); Width: 1 3/8" (41mm); Thickness: 1/4" (6mm)

Note : When used for mechanical supports, load capacities of brackets and fittings should be in compliance with the American Standard Code for Pressure Piping.



P2494 R-L THRU P2499 R-L

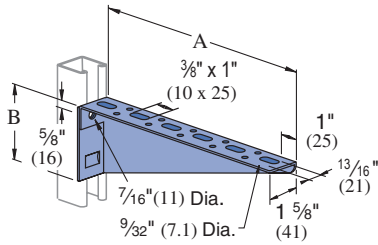

| Part No. | Vertical Channel Gauge | Uniform Design Load Lbs (kN) |
|----------|------------------------|------------------------------|
| P1000 | 12 | 300 (1.33) |
| P1100 | 14 | 250 (1.11) |
| P2000 | 16 | 200 (.89) |

Safety Factor - 2½

| Part Number | Stamped Ident. No. | "A" In (mm) | "B" In (mm) | Wt/100 pcs Lbs (kg) |
|-------------|--------------------|-------------|--|---------------------|
| P2494 R-L | 121895 R-L | 12 305 | 3 ⁷ / ₁₆ 87 | 152 68.9 |
| P2495 R-L | 121896 R-L | 14 356 | 3 ¹⁵ / ₁₆ 100 | 173 78.5 |
| P2496 R-L | 121897 R-L | 16 406 | 4 ¹ / ₁₆ 113 | 223 101.2 |
| P2497 R-L | 121898 R-L | 18 457 | 4 ¹⁵ / ₁₆ 125 | 266 120.7 |
| P2498 R-L | 121899 R-L | 20 508 | 5 ⁷ / ₁₆ 138 | 308 139.7 |
| P2499 R-L | 121900 R-L | 22 559 | 5 ¹⁵ / ₁₆ 151 | 355 161.0 |

Material : 12 Gauge Steel.
R - As shown; L - Opposite hand

P2500 R-L THRU P2503 R-L

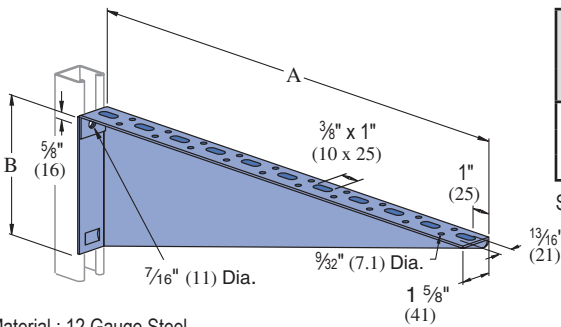

| Part No. | Vertical Channel Gauge | Uniform Design Load Lbs (kN) |
|----------|------------------------|------------------------------|
| P1000 | 12 | 300 (1.33) |
| P1100 | 14 | 250 (1.11) |
| P2000 | 16 | 200 (.89) |

Safety Factor - 2½

| Part Number | Stamped Ident. No. | "A" In (mm) | "B" In (mm) | Wt/100 pcs Lbs (kg) |
|-------------|--------------------|-------------|--|---------------------|
| P2500 R-L | 121901 R-L | 24 610 | 6 ⁷ / ₁₆ 164 | 400 181.4 |
| P2501 R-L | 121902 R-L | 26 660 | 6 ¹⁵ / ₁₆ 176 | 445 201.8 |
| P2502 R-L | 121903 R-L | 28 711 | 7 ⁷ / ₁₆ 189 | 493 223.6 |
| P2503 R-L | 121904 R-L | 30 762 | 7 ¹⁵ / ₁₆ 202 | 545 247.2 |

Material : 12 Gauge Steel.
R - As shown; L - Opposite hand

P2944, P2945, P2946, P2947

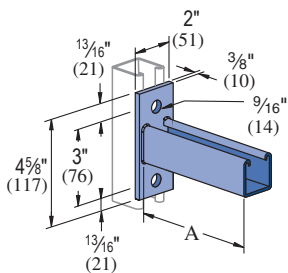

| Part Number | "A" In (mm) | Wt/100 pcs Lbs (kg) | Uniform Load* Lbs (kN) |
|-------------|-------------|---------------------|------------------------|
| P2944 | 6 152 | 185 84 | 1200 5.34 |
| P2945 | 12 305 | 293 133 | 600 2.67 |
| P2946 | 18 457 | 401 182 | 400 1.78 |
| P2947 | 24 610 | 509 231 | 300 1.33 |

Safety Factor 2½
* Mounted on 12 Ga. Channel

P2542 THRU P2546

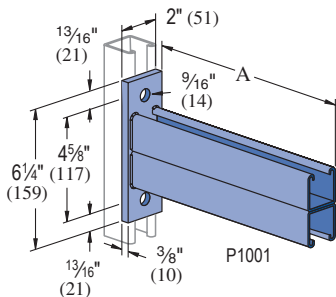

Safety Factor - 2½

| Part Number | "A" In (mm) | Wt/100 pcs Lbs (kg) | Vertical Channel Part No. | Gauge | Uniform Design Load Lbs (kN) |
|-------------|-------------|---------------------|---------------------------|-------|------------------------------|
| P2542 | 12 305 | 502 228 | P1000 | 12 | 2,000 (8.90) |
| | | | P1100 | 14 | 1,400 (6.23) |
| | | | P2000 | 16 | 1,000 (4.45) |
| P2543 | 18 457 | 692 314 | P1000 | 12 | 1,300 (5.78) |
| | | | P1100 | 14 | 900 (4.00) |
| | | | P2000 | 16 | 650 (2.89) |
| P2544 | 24 610 | 882 400 | P1000 | 12 | 1,000 (4.45) |
| | | | P1100 | 14 | 700 (3.11) |
| | | | P2000 | 16 | 500 (2.22) |
| P2545 | 30 762 | 1,072 486 | P1000 | 12 | 800 (3.56) |
| | | | P1100 | 14 | 560 (2.49) |
| | | | P2000 | 16 | 400 (1.78) |
| P2546 | 36 914 | 1,262 572 | P1000 | 12 | 650 (2.89) |
| | | | P1100 | 14 | 450 (2.00) |
| | | | P2000 | 16 | 320 (1.42) |

Standard Dimensions for 1½" (41mm) width series channel fittings (Unless Otherwise Shown on Drawing)

Hole Diameter: 9/16" (14mm); Hole Spacing - From End: 13/16" (21mm); Hole Spacing - On Center: 1 7/8" (48mm); Width: 1 5/8" (41mm); Thickness: 1/4" (6mm)

Note : When used for mechanical supports, load capacities of brackets and fittings should be in compliance with the American Standard Code for Pressure Piping.

P2231, P2232

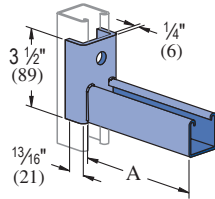

| Part Number | "A" In (mm) | Wt/100 pcs Lbs (kg) | Vertical Channel Part No. | Gauge | Uniform Design Load Lbs (kN) |
|-------------|-------------|---------------------|---------------------------|-------|------------------------------|
| P2231 | 6 | 191 | P1000 | 12 | 1,600 (7.12) |
| | 152 | 86.6 | P1100 | 14 | 1,200 (5.34) |
| | | | P2000 | 16 | 800 (3.56) |
| P2232 | 12 | 292 | P1000 | 12 | 800 (3.56) |
| | 305 | 132.4 | P1100 | 14 | 600 (2.67) |
| | | | P2000 | 16 | 400 (1.78) |

Safety Factor - 2½

P2231A, P2232A

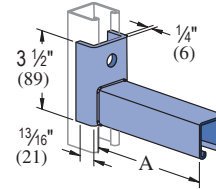

| Part Number | "A" In (mm) | Wt/100 pcs Lbs (kg) | Vertical Channel Part No. | Gauge | Uniform Design Load Lbs (kN) |
|-------------|-------------|---------------------|---------------------------|-------|------------------------------|
| P2231A | 6 | 191 | P1000 | 12 | 1,600 (7.12) |
| | 152 | 86.6 | P1100 | 14 | 1,200 (5.34) |
| | | | P2000 | 16 | 800 (3.56) |
| P2232A | 12 | 292 | P1000 | 12 | 800 (3.56) |
| | 305 | 132.4 | P1100 | 14 | 600 (2.67) |
| | | | P2000 | 16 | 400 (1.78) |

Safety Factor - 2½

P2233, P2234

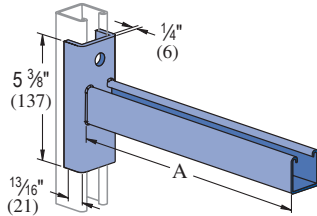

| Part Number | "A" In (mm) | Wt/100 pcs Lbs (kg) | Vertical Channel Part No. | Gauge | Uniform Design Load Lbs (kN) |
|-------------|-------------|---------------------|---------------------------|-------|------------------------------|
| P2233 | 18 | 436 | P1000 | 12 | 600 (2.67) |
| | 457 | 197.8 | P1100 | 14 | 450 (2.00) |
| | | | P2000 | 16 | 300 (1.33) |
| P2234 | 24 | 536 | P1000 | 12 | 450 (2.00) |
| | 610 | 243.1 | P1100 | 14 | 330 (1.47) |
| | | | P2000 | 16 | 220 (.98) |

Safety Factor - 2½

P2233A, P2234A

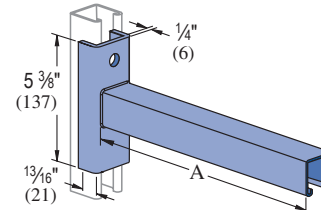

| Part Number | "A" In (mm) | Wt/100 pcs Lbs (kg) | Vertical Channel Part No. | Gauge | Uniform Design Load Lbs (kN) |
|-------------|-------------|---------------------|---------------------------|-------|------------------------------|
| P2233A | 18 | 436 | P1000 | 12 | 600 (2.67) |
| | 457 | 197.8 | P1100 | 14 | 450 (2.00) |
| | | | P2000 | 16 | 300 (1.33) |
| P2234A | 24 | 536 | P1000 | 12 | 450 (2.00) |
| | 610 | 243.1 | P1100 | 14 | 330 (1.47) |
| | | | P2000 | 16 | 220 (.98) |

Safety Factor - 2½

P2513 THRU P2516

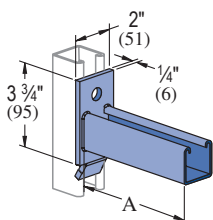

When installed in inverted position use 60% of loads shown.

Safety Factor 2½

| Part Number | "A" In (mm) | Wt/100 pcs Lbs (kg) | Vertical Channel Part No. | Gauge | Uniform Design Load Lbs (kN) |
|-------------|-------------|---------------------|---------------------------|-------|------------------------------|
| P2513 | 6 | 161 | P1000 | 12 | 1,200 (5.34) |
| | 152 | 73.0 | P1100 | 14 | 800 (3.56) |
| | | | P2000 | 16 | 600 (2.67) |
| P2514 | 12 | 261 | P1000 | 12 | 600 (2.67) |
| | 305 | 118.4 | P1100 | 14 | 400 (1.78) |
| | | | P2000 | 16 | 300 (1.33) |
| P2515 | 18 | 361 | P1000 | 12 | 400 (1.78) |
| | 457 | 163.7 | P1100 | 14 | 270 (1.20) |
| | | | P2000 | 16 | 200 (.89) |
| P2516 | 24 | 461 | P1000 | 12 | 300 (1.33) |
| | 610 | 209.1 | P1100 | 14 | 200 (.89) |
| | | | P2000 | 16 | 150 (.67) |

P2513A THRU P2516A

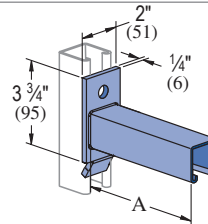

When installed in inverted position use 60% of loads shown.

Safety Factor 2½

| Part Number | "A" In (mm) | Wt/100 pcs Lbs (kg) | Vertical Channel Part No. | Gauge | Uniform Design Load Lbs (kN) |
|-------------|-------------|---------------------|---------------------------|-------|------------------------------|
| P2513A | 6 | 161 | P1000 | 12 | 1,200 (5.34) |
| | 152 | 73.0 | P1100 | 14 | 800 (3.56) |
| | | | P2000 | 16 | 600 (2.67) |
| P2514A | 12 | 261 | P1000 | 12 | 600 (2.67) |
| | 305 | 118.4 | P1100 | 14 | 400 (1.78) |
| | | | P2000 | 16 | 300 (1.33) |
| P2515A | 18 | 361 | P1000 | 12 | 400 (1.78) |
| | 457 | 163.7 | P1100 | 14 | 270 (1.20) |
| | | | P2000 | 16 | 200 (.89) |
| P2516A | 24 | 461 | P1000 | 12 | 300 (1.33) |
| | 610 | 209.1 | P1100 | 14 | 200 (.89) |
| | | | P2000 | 16 | 150 (.67) |

Standard Dimensions for 1½" (41mm) width series channel fittings (Unless Otherwise Shown on Drawing)

Hole Diameter: 5/16" (14mm); Hole Spacing - From End: 13/16" (21mm); Hole Spacing - On Center: 1 1/8" (48mm); Width: 1 1/2" (41mm); Thickness: 1/4" (6mm)

Note : When used for mechanical supports, load capacities of brackets and fittings should be in compliance with the American Standard Code for Pressure Piping.



P2815

ADJUSTABLE BRACE FITTING

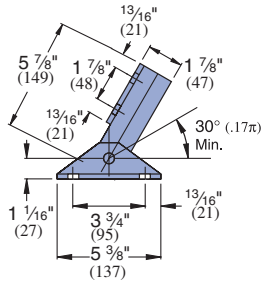
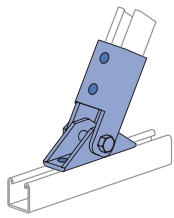

Wt/100 pcs: 307 Lbs (139.3 kg)

P2815D

ADJUSTABLE BRACE FITTING

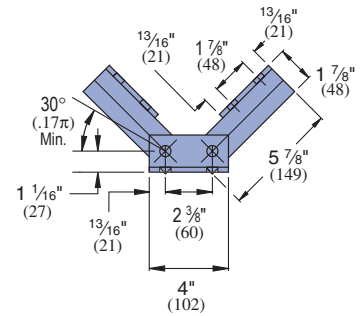
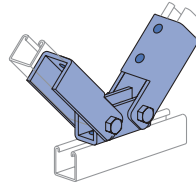

Wt/100 pcs: 497 Lbs (225.4 kg)

P2452

KNEE BRACE

P2458-18 THRU P2458-36

TUBULAR KNEE BRACES

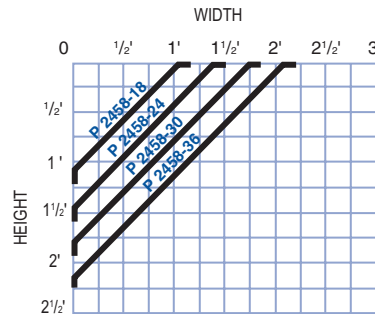
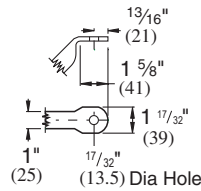
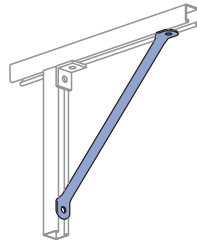
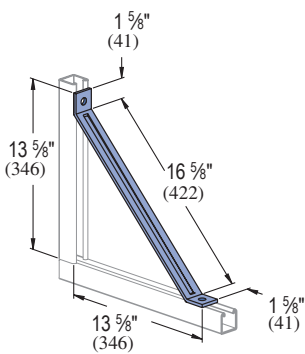

| Part Number | "A" In (mm) | Wt/100 pcs Lbs (kg) |
|-------------|-------------|---------------------|
| P2458-18 | 18 | 146 |
| P2458-24 | 24 | 186 |
| P2458-30 | 30 | 227 |
| P2458-36 | 36 | 267 |
| | 914 | 121.1 |

Design Axial Load
1200 Lbs (5.34 kN)

Material: 1/4" (6.4) thick steel.

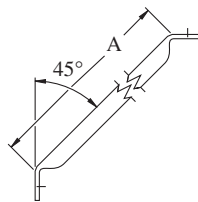

Design Loads
Compression = 1500 Lbs (6.67 kN)
Tension = 300 Lbs (1.33 kN)

Wt/100 pcs: 277 Lbs (125.6 kg)

P2459-36 THRU P2459-96

TUBULAR BACK BRACES

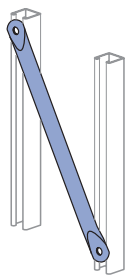

1. The vertical lines of the graph correspond to the center to center line dimension of the uprights.
2. Along this vertical line locate the (maximum usable) horizontal bracing height line.
3. The arc line that intersects the point formed by the intersection of the two lines, indicates the brace required.
4. 60° - 30° maximum, minimum brace angles are indicated for maximum effect.

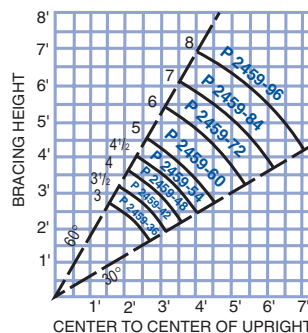
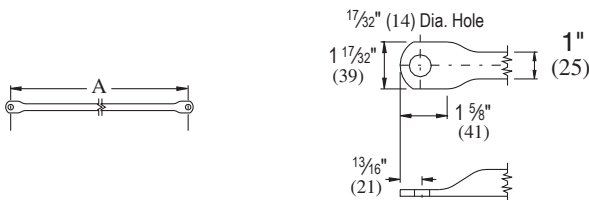

| Part Number | "A" In (mm) | Wt/100 pcs Lbs (kg) |
|-------------|-------------|---------------------|
| P2459-36 | 36 | 255 |
| | 914 | 115.7 |
| P2459-42 | 42 | 296 |
| | 1,067 | 134.3 |
| P2459-48 | 48 | 336 |
| | 1,219 | 152.4 |
| P2459-54 | 54 | 377 |
| | 1,372 | 171.0 |
| P2459-60 | 60 | 418 |
| | 1,524 | 189.6 |
| P2459-72 | 72 | 499 |
| | 1,829 | 226.3 |
| P2459-84 | 84 | 580 |
| | 2,134 | 263.1 |
| P2459-96 | 96 | 661 |
| | 2,438 | 299.8 |

Standard Dimensions for 1 1/2" (41mm) width series channel fittings (Unless Otherwise Shown on Drawing)

Hole Diameter: 9/16" (14mm); Hole Spacing - From End: 13/16" (21mm); Hole Spacing - On Center: 1 1/8" (48mm); Width: 1 1/2" (41mm); Thickness: 1/4" (6mm)

Note : When used for mechanical supports, load capacities of brackets and fittings should be in compliance with the American Standard Code for Pressure Piping.

P2897

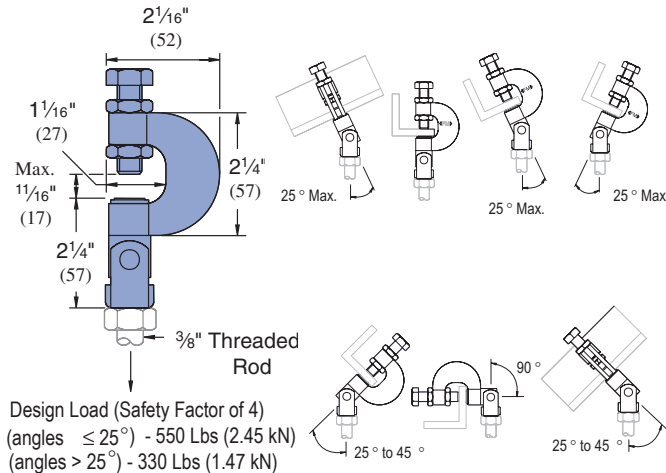

Safety Factor 4
 Torque: 13 Ft-Lbs (18 N*m)

Wt/100 pcs: 33 Lbs (15.0 kg)

P2784

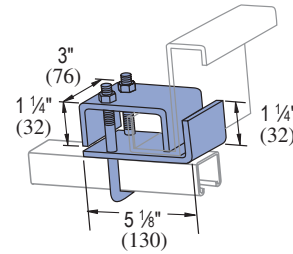

| Part Number | For Use With | Load Lbs (kN) | Wt/100 pcs Lbs (kg) |
|-------------|--------------|---------------|---------------------|
| P2784-1 | P1000, | 1,200 | 175 |
| | P1100, | 5.34 | 79.3 |
| | P2000 | | |
| P2784-2 | P1001, | 1,200 | 179 |
| | P1101, | 5.34 | 81.1 |
| | P2001 | | |
| P2784-3 | P5001, | 1,200 | 180 |
| | P5501 | 5.34 | 81.5 |

PFL2-37

SWIFTGRIP

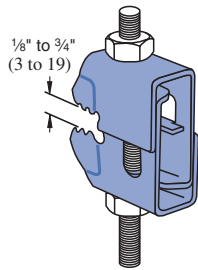

Designed to significantly reduce installation time, while offering greater performance than cast beam clamps, the Swiftgrip enables connection of drop rod to beam in one simple operation. Ideal for the suspension of building services equipment including heating, ventilating and air conditioning equipment; pipework; fire protection systems; electrical equipment and cable tray.

Available finish choices are Stainless Steel or Perma-Gold™ Industry Standard Yellow Dichromate.
 Design Load is 540 Lbs (2.40 kN).
 Safety Factor is 4
 Torque is 8 Ft/Lbs (10.8 N*m)
 Rod Size is $\frac{3}{8}"$ (9.5mm)

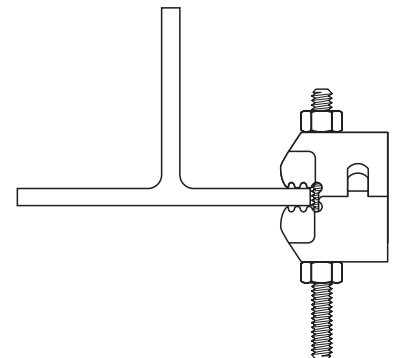

Wt/100 pcs: 26 Lbs (11.9 kg)

P2675

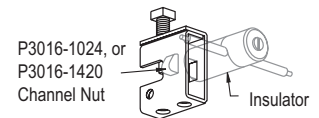
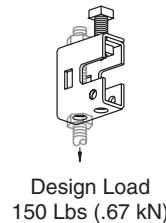
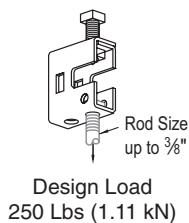
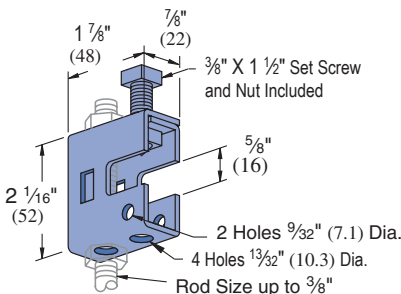

Clamp Materials: .105" (2.7) thick steel.
 Clamp P2675 is designed for light duty rod suspension.
 It also may be used with P3016-1024 or P3016-1420 nut as illustrated above for mounting insulators, etc.

Wt/100 pcs: 33 Lbs (15.0 kg)

Standard Dimensions for $1\frac{3}{8}"$ (41mm) width series channel fittings (Unless Otherwise Shown on Drawing)

Hole Diameter: $\frac{9}{16}"$ (14mm); Hole Spacing - From End: $\frac{13}{16}"$ (21mm); Hole Spacing - On Center: $1\frac{7}{8}"$ (48mm); Width: $1\frac{1}{8}"$ (41mm); Thickness: $\frac{1}{4}"$ (6mm)

Note: When used for mechanical supports, load capacities of brackets and fittings should be in compliance with the American Standard Code for Pressure Piping. Clamps are designed to be used with W, M, S & HP Shape beams, Standard C & Misc. MC Channels, Angles & Structural Tees. Clamps must be used in pairs where indicated. For beam clamps with HG finish, standard hardware is EG finish. For optional stainless steel hardware, please contact the factory for availability.

P2676

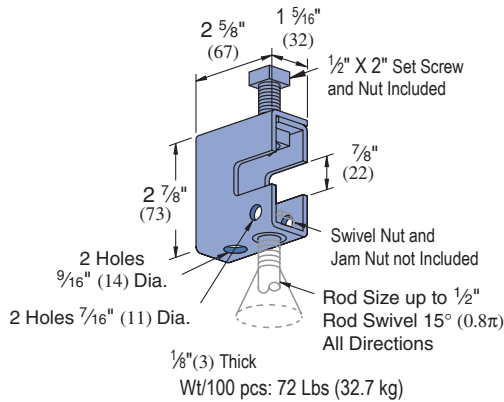

Wt/100 pcs: 72 Lbs (32.7 kg)

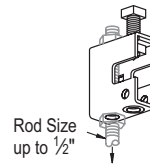

Design Load
300 Lbs (1.33 kN)



Design Load
500 Lbs (2.22 kN)

Clamp P2676 provides a means of rod suspension where a free swing of up to 15° (0.8π) is required. Clamp will accommodate 1/4" (6), 3/8" (10), or 1/2" (13) rods. Order swivel nuts P2679-4, -6, or -8 as required. Clamp may also be used with P2677 as illustrated in application drawings.

Clamp Materials: 1/8" (3.2) thick steel.

P2898

UNIVERSAL BEAM CLAMP

- Maximum temperature of 450° F (232° C)
- At least one full thread must be exposed

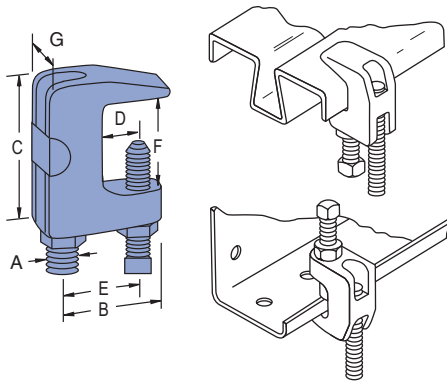

| | A In | B In (mm) | C In (mm) | D In (mm) | E In (mm) | F In (mm) | G In (mm) | Max Load Lbs (kN) | Wt/100 pcs Lbs (kg) |
|----------|---------|--------------|--------------|--------------|--------------|--------------|--------------|----------------------|------------------------|
| P2898-37 | 3/8 | 1 | 1 1/2 | 1/2 | 1 | 3/4 | 7/8 | 400 1.78 | 33 15.0 |
| P2898-50 | 1/2 | 1 | 1 1/2 | 1/2 | 1 | 3/4 | 7/8 | 500 2.22 | 33 15.0 |
| P2898-62 | 5/8 | 1 1/2 | 1 1/2 | 1/2 | 1 | 3/4 | 1 | 600 2.67 | 22 10.0 |
| P2898-75 | 3/4 | 1 1/2 | 1 3/4 | 5/8 | 1 1/2 | 1 | 1 1/4 | 800 3.56 | 88 40.0 |
| P2898-87 | 7/8 | 2 | 1 3/4 | 5/8 | 1 1/2 | 1 | 1 1/4 | 1,200 5.34 | 79 35.9 |

P2899

WIDE THROAT BEAM CLAMP

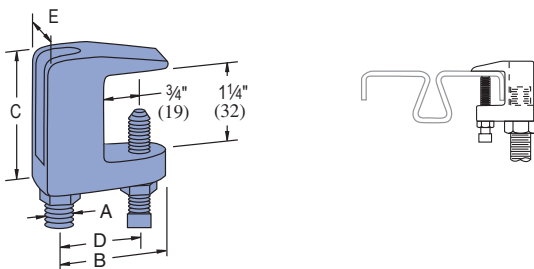

- Maximum temperature of 450° F (232° C)

| | Rod Size | | | | | Max. Load Lbs (kN) | Wt/100 pcs Lbs (kg) |
|----------|----------|--------------|--------------|--------------|--------------|-----------------------|------------------------|
| | A in | B In (mm) | C In (mm) | D In (mm) | E In (mm) | | |
| P2899-37 | 3/8 | 1 5/8 | 2 | 1 | 7/8 | 400 1.78 | 28 12.7 |
| P2899-50 | 1/2 | 1 5/8 | 2 | 1 | 7/8 | 500 2.22 | 34 15.4 |
| P2899-62 | 5/8 | 1 3/4 | 2 1/4 | 1 1/4 | 1 | 600 2.67 | 66 30.0 |
| P2899-75 | 3/4 | 1 7/8 | 2 3/8 | 1 3/8 | 1 1/4 | 800 3.56 | 83 37.7 |

P2682

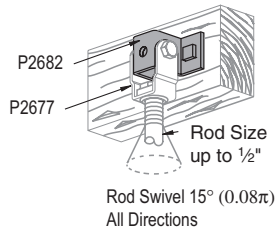
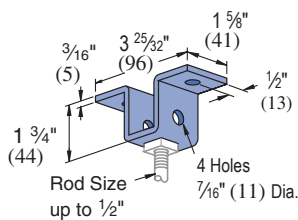

Hanger clevis for up to 1/2" (12.7) rod suspension from wood ceilings. May also be used with P2677 as illustrated in application drawings.

Wt/100 pcs: 55 Lbs (24.9 kg)

P2677

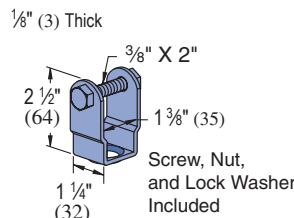

Clevis hanger to be used with P2676 or P2682 to provide angle adjustment and 15° (0.08 π) free swing for up to 1/2" (13) rod suspension. Order swivel nuts P2679-4, -6, or -8 as required.

Wt/100 pcs: 30 Lbs (13.6 kg)

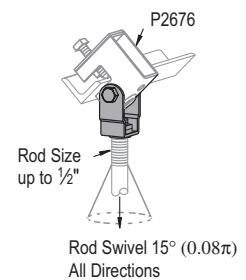

Design Load
500 Lbs (2.22 kN)

Note: When used for mechanical supports, load capacities of brackets and fittings should be in compliance with the American Standard Code for Pressure Piping. Clamps are designed to be used with W, M, S & HP Shape beams, Standard C & Misc. MC Channels, Angles & Structural Tees. Clamps must be used in pairs where indicated. For beam clamps with HG finish, standard hardware is EG finish. For optional stainless steel hardware, please contact the factory for availability.

P2674

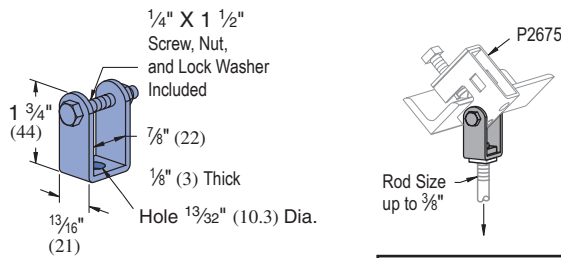

Clevis hanger to be used with P2675 to provide angle adjustment for up to 3/8" rod suspension as illustrated.

Wt/100 pcs: 17 Lbs (7.7 kg)

Design Load
250 Lbs (1.11 kN)

P2679-4, -6 & -8

SWIVEL NUT

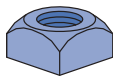

| Part Number | Thread Size | Wt/100 pcs Lbs (kg) |
|-------------|-------------|---------------------|
| P2679-4 | 1/4"-20 | 4 1.8 |
| P2679-6 | 3/8"-16 | 5 2.3 |
| P2679-8 | 1/2"-13 | 6 2.7 |

- Use with P2676 and P2677.
- Order size as required.

P2398S, P2401S, P2403S, P2405S

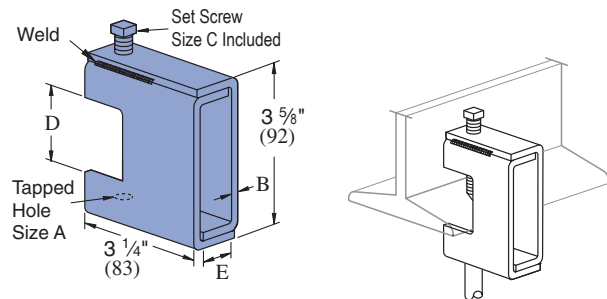

Weld is not continuous it is either 1 1/4" (32) - 1 3/4" (44) long or 2 spot welds. All welds are on the top and bottom.

| Part Number | "A" In | "B" In (mm) | "C" In | "D" In (mm) | "E" In (mm) | Wt/100 pcs Lbs (kg) | Design Load Lbs (kN) |
|-------------|----------|-------------|---------|---------------|-------------|---------------------|----------------------|
| P2398S | 1/4 - 20 | 1/8 3 | 3/8 x 2 | 1 21/32 42 | 7/8 22 | 109 49.4 | 800 3.56 |
| P2401S | 3/8 - 16 | 3/16 5 | 1/2 x 2 | 1 11/16 43 | 29/32 23 | 156 70.8 | 1,300 5.78 |
| P2403S | 1/2 - 13 | 1/4 6 | 1/2 x 2 | 1 11/16 43 | 15/16 24 | 201 91.2 | 1,900 8.45 |
| P2405S | 5/8 - 11 | 5/16 8 | 5/8 x 2 | 1 11/16 43 | 1 1/2 33 | 311 141.1 | 2,400 10.68 |

For beams between 3/4" (19) to 1 5/8" (41) thick flanges.

P1648S THRU P1653S

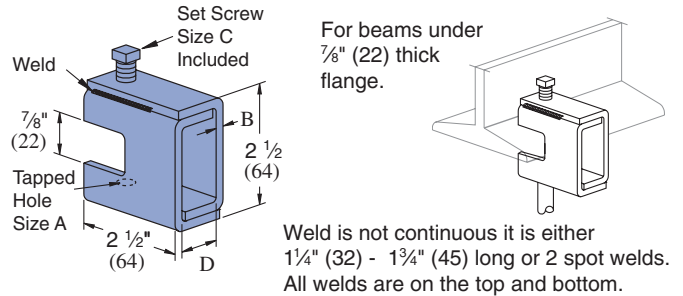

| Part Number | "A" In | "B" In (mm) | "C" In | "D" In (mm) | Wt/100 pcs Lbs (kg) | Design Load Lbs (kN) |
|-------------|-----------|-------------|-------------|-------------|---------------------|----------------------|
| P1648S | 1/4 - 20 | 3 | 3/8 x 1 1/2 | 7/8 22 | 67 30.4 | 650 2.89 |
| P1649S | 5/16 - 18 | 3 | 3/8 x 1 1/2 | 7/8 22 | 67 30.4 | 650 2.89 |
| P1649AS | 3/8 - 16 | 3 | 3/8 x 1 1/2 | 7/8 22 | 67 30.4 | 650 2.89 |
| P1650S | 3/8 - 16 | 5 | 1/2 x 1 1/2 | 15/16 24 | 100 45.4 | 1,100 4.89 |
| P1650AS | 1/2 - 13 | 5 | 1/2 x 1 1/2 | 15/16 24 | 100 45.4 | 1,100 4.89 |
| P1651S | 1/2 - 13 | 6 | 1/2 x 1 1/2 | 15/16 24 | 130 59.0 | 1,600 7.12 |
| P1651AS | 5/8 - 11 | 6 | 1/2 x 1 1/2 | 15/16 24 | 130 59.0 | 1,600 7.12 |
| P1652S | 5/8 - 11 | 8 | 5/8 x 1 1/2 | 1 1/2 33 | 160 72.6 | 2,400 10.68 |
| P1653S | 3/4 - 10 | 88 | 5/8 x 1 1/2 | 1 1/2 33 | 160 72.6 | 2,400 10.68 |

P1654A THRU P1661A

RETAINER STRAP

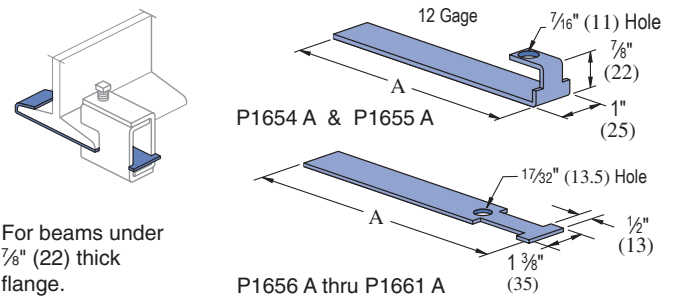

For beams under 7/8" (22) thick flange.

| Strap Part Number | Flange Width In (mm) | "A" In (mm) | Wt/100 pcs Lbs (kg) | Beam Clamp Used With |
|-------------------|----------------------|-------------|---------------------|---|
| P1654 A | 6 152 | 7 178 | 25 11.3 | P2675 |
| P1655 A | 9 229 | 10 254 | 34 15.4 | P2675 |
| P1656 A | 6 152 | 9 229 | 35 15.9 | P1648 S Thru P1651 AS, & P2398 S Series |
| P1657 A | 9 229 | 12 305 | 47 21.3 | |
| P1658 A | 12 305 | 15 381 | 59 26.8 | |
| P1659 A | 6 152 | 9 229 | 33 15.0 | P2676 |
| P1660 A | 9 229 | 12 305 | 45 20.4 | P2676 |
| P1661 A | 12 305 | 15 381 | 57 25.9 | P2676 |

Note: When used for mechanical supports, load capacities of brackets and fittings should be in compliance with the American Standard Code for Pressure Piping. Clamps are designed to be used with W, M, S & HP Shape beams, Standard C & Misc. MC Channels, Angles & Structural Tees. Clamps must be used in pairs where indicated. For beam clamps with HG finish, standard hardware is EG finish. For optional stainless steel hardware, please contact the factory for availability.



P1271S

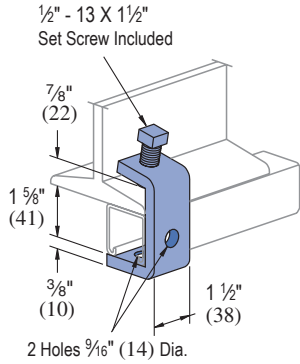

Note: Requires P1010 Channel Nut and bolt.

Design Load Each
500 Lbs (2.22 kN)
Use in Pairs Only

Wt/100 pcs: 95 Lbs (43.1 kg)

P1796S

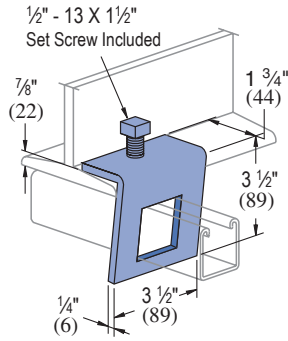

Design Load Each
500 Lbs (2.22 kN)
Use in Pairs Only

Wt/100 pcs: 91 Lbs (41.3 kg)

P2824-6,-9,-12

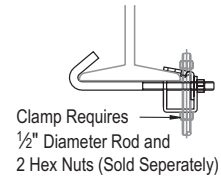
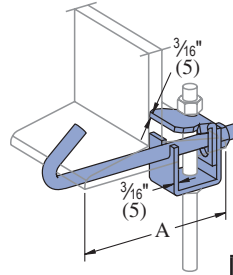

| Part Number | "A" In (mm) | Wt/100 pcs Lbs (kg) | Design Load Lbs (kN) |
|-------------|-------------|---------------------|----------------------|
| P2824-6 | 2 1/2 - 6 | 125 | 500 |
| | 64 - 152 | 56.7 | 2.22 |
| P2824-9 | 5 1/2 - 9 | 140 | 500 |
| | 140 - 229 | 63.5 | 2.22 |
| P2824-12 | 8 1/2 - 12 | 171 | 500 |
| | 216 - 305 | 77.6 | 2.22 |

P2785

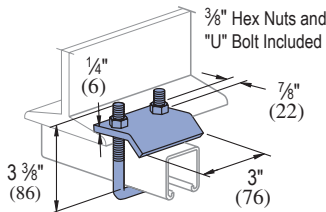

• For use with Beams up to 3/4" (19) Flanges and with Channels P1000, P1100, P2000, P3000, P3300, P3301, P4000, P4001, P4100, and P4101.

Design Load Each
1000 Lbs (4.45 kN)
Use in Pairs Only

Wt/100 pcs: 83 Lbs (37.6 kg)

P2786

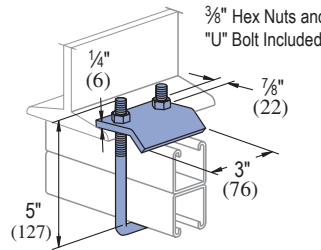

• For use with Beams up to 3/4" (19) Flanges and with Channels P1001, P1101, P2001, P3001, P5000, and P5500.

Design Load Each
1000 Lbs (4.45 kN)
Use in Pairs Only

Wt/100 pcs: 92 Lbs (41.7 kg)

P2787

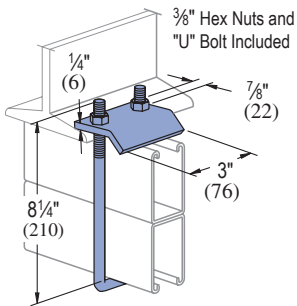

• For use with Beams up to 3/4" (19) Flanges and with Channels P5001 and P5501.

Design Load Each
1000 Lbs (4.45 kN)
Use in Pairs Only

Wt/100 pcs: 112 Lbs (50.8 kg)

P2867

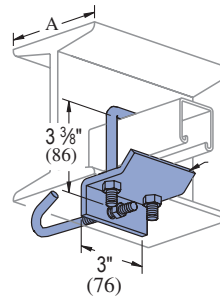

| Part Number | Beam Size "A" | Wt/100 pcs Lbs (kg) |
|-------------|---------------|---------------------|
| P2867 | 4"-6" | 142 (64.4) |
| P2867-9 | 6"-9" | 151 (68.5) |
| P2867-12 | 9"-12" | 160 (72.6) |
| P2867-15 | 12"-15" | 170 (77.1) |
| P2867-18 | 15"-18" | 179 (81.2) |

• Includes: "J" Bolt, "U" Bolt and Hex Nuts.

• For use with Channels P1000, P1100, P2000, P3000, P3300, P3301, P4000, P4001, P4100, and P4101.

P2867A

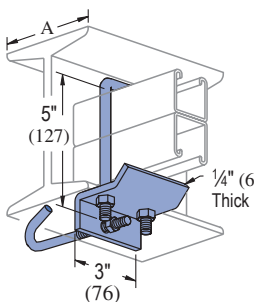

| Part Number | Beam Size "A" | Wt/100 pcs Lbs (kg) |
|-------------|---------------|---------------------|
| P2867A | 4"-6" | 151 (68.5) |
| P2867A-9 | 6"-9" | 157 (71.2) |
| P2867A-12 | 9"-12" | 166 (75.3) |
| P2867A-15 | 12"-15" | 176 (79.8) |
| P2867A-18 | 15"-18" | 185 (83.9) |

• Includes: "J" Bolt, "U" Bolt and Hex Nuts.

• For use with Channel P1001, P1101, P2001, P3001, P5000, and P5500.

P2867B

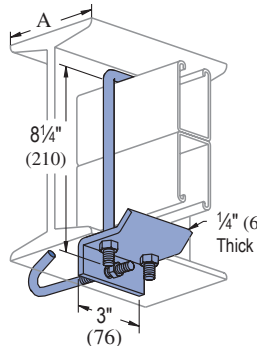

| Part Number | Beam Size "A" | Wt/100 pcs Lbs (kg) |
|-------------|---------------|---------------------|
| P2867B | 4"-6" | 161 (73.0) |
| P2867B-9 | 6"-9" | 167 (75.7) |
| P2867B-12 | 9"-12" | 176 (79.8) |
| P2867B-15 | 12"-15" | 186 (84.4) |
| P2867B-18 | 15"-18" | 195 (88.5) |

• Includes: "J" Bolt, "U" Bolt and Hex Nuts.

• For use with Channel P5001, and P5501.

Note: When used for mechanical supports, load capacities of brackets and fittings should be in compliance with the American Standard Code for Pressure Piping. Clamps are designed to be used with W, M, S & HP Shape beams, Standard C & Misc. MC Channels, Angles & Structural Tees. Clamps must be used in pairs where indicated. For beam clamps with HG finish, standard hardware is EG finish. For optional stainless steel hardware, please contact the factory for availability.

P2868

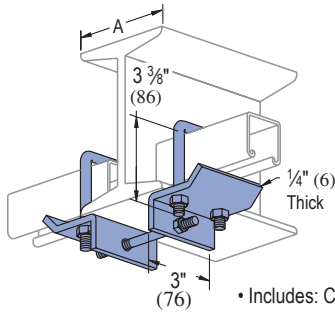

| Part Number | Beam Size "A" | Wt/100 pcs Lbs (kg) |
|-------------|---------------|---------------------|
| P2868 | 4"-6" | 282 (127.9) |
| P2868-9 | 6"-9" | 289 (131.1) |
| P2868-12 | 9"-12" | 296 (134.3) |
| P2868-15 | 12"-15" | 304 (137.9) |
| P2868-18 | 15"-18" | 311 (141.1) |

- Includes: Center Rod, "U" Bolts and Hex Nuts.
- For use with Channels P1000, P1100, P2000, P3000, P3300, P3301, P4000, P4001, P4100, and P4101.

P2868A

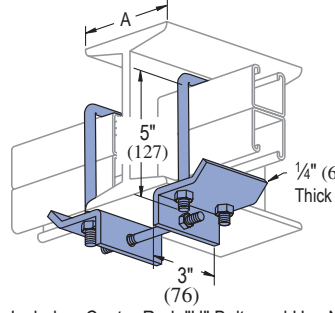

| Part Number | Beam Size "A" | Wt/100 pcs Lbs (kg) |
|-------------|---------------|---------------------|
| P2868A | 4"-6" | 300 (136.1) |
| P2868A-9 | 6"-9" | 307 (139.3) |
| P2868A-12 | 9"-12" | 314 (142.2) |
| P2868A-15 | 12"-15" | 322 (146.1) |
| P2868A-18 | 15"-18" | 329 (149.2) |

- Includes: Center Rod, "U" Bolts and Hex Nuts.
- For use with Channels P1001, P1101, P2001, P3001, P5000, and P5500.

P2868B

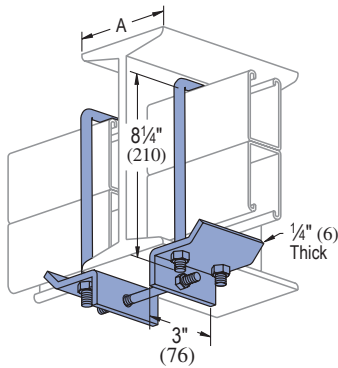

| Part Number | Beam Size "A" | Wt/100 pcs Lbs (kg) |
|-------------|---------------|---------------------|
| P2868B | 4"-6" | 320 (145.1) |
| P2868B-9 | 6"-9" | 327 (148.3) |
| P2868B-12 | 9"-12" | 334 (151.5) |
| P2868B-15 | 12"-15" | 342 (155.1) |
| P2868B-18 | 15"-18" | 349 (153.3) |

- Includes: Center Rod, "U" Bolts and Hex Nuts.
- For use with Channels P5001, and P5501.

P2894

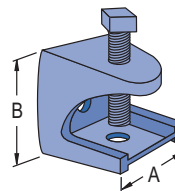

Material: Malleable Iron
 7/8" Maximum Flange Thickness
 Note: Tapped Hole on Top and Bottom

| Part Number | Rod Size In | "A" In (mm) | "B" In (mm) | Load Ratings Lbs (kN) | Wt/100 pcs Lbs (kg) |
|-------------|-------------|-------------|-------------|-----------------------|---------------------|
| P2894-25 | 1/4 | 1 1/8 | 1 1/4 | 150 | 23 |
| | | 29 | 32 | .67 | 10.4 |
| P2894-37 | 3/8 | 2 | 2 | 350 | 95 |
| | | 51 | 51 | 1.56 | 43.1 |
| P2894-50 | 1/2 | 2 5/8 | 2 1/2 | 400 | 195 |
| | | 67 | 64 | 1.78 | 88.5 |

P2893

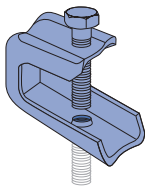

Material: Steel
 Use With: 1/4" rod
 Load Rating: 75 lbs. (.33 kN)

Wt/100 pcs: 14 lbs. (6.4 kg)

P2895

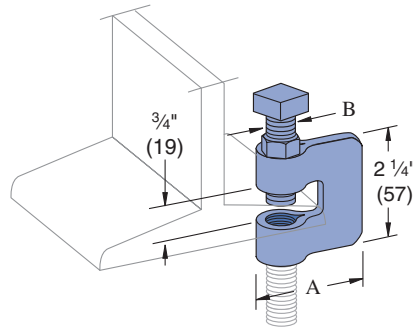

Material: Steel

| Part Number | Rod Size In | "A" In (mm) | "B" In (mm) | Load Ratings Lbs (kN) | Wt/100 pcs Lbs (kg) |
|-------------|-------------|-------------|-------------|-----------------------|---------------------|
| P2895-37 | 3/8 | 2 5/16 | 3/8 | 330 | 35 |
| | | 59 | 10 | 1.47 | 15.9 |
| P2895-50 | 1/2 | 2 1/4 | 1/2 | 380 | 41 |
| | | 57 | 13 | 1.69 | 18.6 |
| P2895-62 | 5/8 | 2 3/8 | 5/8 | 450 | 67 |
| | | 60 | 16 | 2.00 | 30.4 |
| P2895-75 | 3/4 | 2 1/4 | 1/2 | 500 | 72 |
| | | 57 | 13 | 2.22 | 32.7 |

P2896

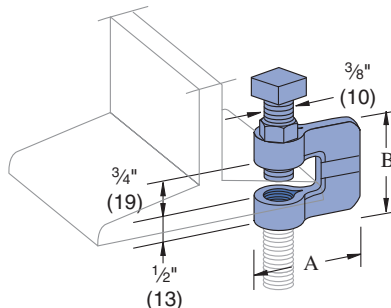

Material: Malleable Iron,
 Steel Set Screw

| Part Number | Rod Size In | "A" In (mm) | "B" In (mm) | Load Ratings Lbs (kN) | Wt/100 pcs Lbs (kg) |
|-------------|-------------|-------------|-------------|-----------------------|---------------------|
| P2896-37 | 3/8 | 1 11/16 | 1 1/4 | 400 | 38 |
| | | 43 | 45 | 1.78 | 17.2 |
| P2896-50 | 1/2 | 1 23/32 | 1 3/4 | 400 | 52 |
| | | 44 | 45 | 1.78 | 23.6 |
| P2896-62 | 5/8 | 1 15/16 | 2 | 450 | 68 |
| | | 49 | 51 | 2.00 | 30.8 |
| P2896-75 | 3/4 | 2 1/32 | 2 | 600 | 128 |
| | | 52 | 51 | 2.67 | 58.1 |

Standard Dimensions for 1 3/8" (41mm) width series channel fittings (Unless Otherwise Shown on Drawing)

Hole Diameter: 9/16" (14mm); Hole Spacing - From End: 1 3/16" (21mm); Hole Spacing - On Center: 1 1/8" (48mm); Width: 1 1/8" (41mm); Thickness: 1/4" (6mm)

Note: When used for mechanical supports, load capacities of brackets and fittings should be in compliance with the American Standard Code for Pressure Piping. Clamps are designed to be used with W, M, S & HP Shape beams, Standard C & Misc. MC Channels, Angles & Structural Tees. Clamps must be used in pairs where indicated. For beam clamps with HG finish, standard hardware is EG finish. For optional stainless steel hardware, please contact the factory for availability.



P1386

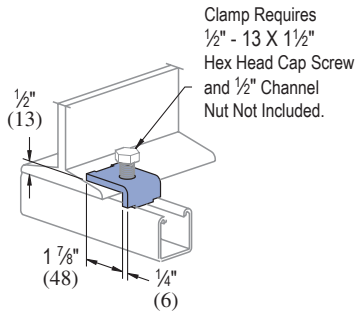

Clamp Requires
1/2" - 13 X 1 1/2"
Hex Head Cap Screw
and 1/2" Channel
Nut Not Included.

| Channel Style | Design Load Each (Use in Pairs Only) Lbs (kN) |
|---------------|---|
| P1000 | 600 2.67 |
| P1100 | 500 2.22 |
| P2000 | 450 2.00 |

Wt/100 pcs: 27 Lbs (12.2 kg)

P1379S

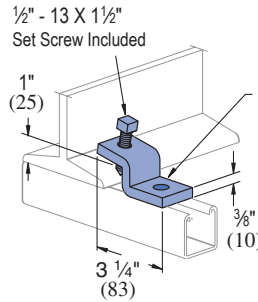

Clamp Requires
1/2" x 1 3/16"
Hex Head Cap Screw
and 1/2" Channel
Nut Not Included.

| Channel Style | Design Load Each (Use in Pairs Only) Lbs (kN) |
|---------------|---|
| P1000 | 600 2.67 |
| P1100 | 500 2.22 |
| P2000 | 450 2.00 |

Wt/100 pcs: 75 Lbs (34.0kg)

P1272S, P1985S, P1986S

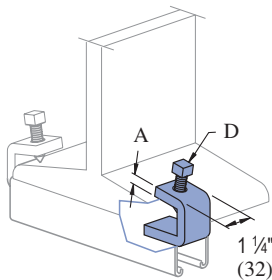

| Part Number | "A" In (mm) | Flange Thickness In (mm) | "D" Set Screw Included | Wt/100 pcs Lbs (kg) | Design Load Per Pair (Use in Pairs Only) Lbs (kN) |
|-------------|-------------|--------------------------|------------------------|---------------------|---|
| P1272S | 1/4 6 | Up to 3/4 Up to 19 | 3/8-16 x 1 1/2 | 39 17.7 | 450 2.00 |
| P1985S | 3/8 10 | Up to 3/4 Up to 19 | 1/2-13 x 1 1/2 | 62 28.1 | 1,000 4.45 |
| P1986S | 3/8 10 | 7/8 to 2 22 - 51 | 1/2-13 x 1 1/2 | 74 33.6 | 900 4.00 |

P3087

COLUMN INSERT

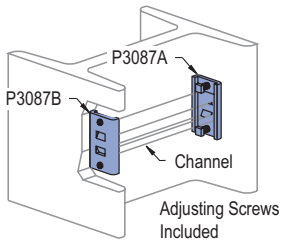

| Channel Part Number | Design Pull Out Load Lbs (kN) | Design Slip Load Lbs (kN) |
|---------------------|-------------------------------|---------------------------|
| P1000 | 1,000 4.45 | 800 3.56 |
| P1100 | 700 3.34 | 500 2.22 |
| P2000 | 500 2.22 | 300 1.33 |

Safety factor of 3.

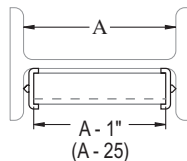

Wt/100 pcs: 136 Lbs (61.7 kg)

- Adjusting Screws Included.
- Unistrut channel not included.
- Part number P3087 consists of:
 - (1) piece P3087A,
 - (1) piece P3087B and
 - (2) set screws, 3/8" Dia.

P3088

COLUMN INSERT

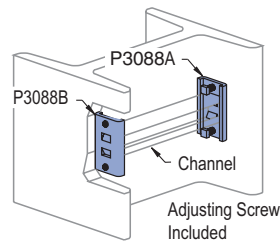

| Channel Part Number | Design Pull Out Load Lbs (kN) | Design Slip Load Lbs (kN) |
|---------------------|-------------------------------|---------------------------|
| P3300 | 1,000 4.45 | 800 3.56 |
| P4100 | 700 3.11 | 500 2.22 |
| P4000 | 500 2.22 | 300 1.33 |

Safety factor of 3.

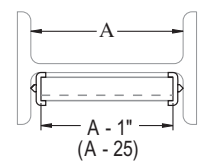

Wt/100 pcs: 120 Lbs (54.4 kg)

- Adjusting Screws Included.
- Unistrut channel not included.
- Part number P3088 consists of:
 - (1) piece P3088A,
 - (1) piece P3088B and
 - (2) set screws, 3/8" Dia.

PLLC025

FLANGE CLAMP

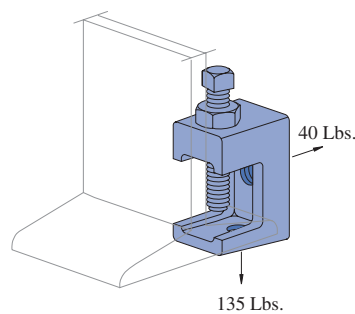

Cup point set screw and lock nut included.

Set Screw Torque = 3 Ft-Lb
Lock Nut Torque = 3.5 Ft-Lb

X, Y are threaded holes.

| Part Number | Rod Size | "Z" Set Screw Size | Wt/100 pcs Lbs (kg) |
|-------------|----------|--------------------|---------------------|
| PLLC025 | 1/4" | 1/4" | 16 (7.3) |

| Part Number | Dimensions | | | | |
|-------------|-------------|-------------|--------------|------------------|-------------|
| | "S" In (mm) | "T" In (mm) | "U" In (mm) | "V", "W" In (mm) | "X", "Y" In |
| PLLC025 | 5/8 16 | 1 25 | 1 1/16 37 | 3/4 19 | 1/4 X 20 |

Material: Malleable Iron.

Note: When used for mechanical supports, load capacities of brackets and fittings should be in compliance with the American Standard Code for Pressure Piping. Clamps are designed to be used with W, M, S & HP Shape beams, Standard C & Misc. MC Channels, Angles & Structural Tees. Clamps must be used in pairs where indicated. For beam clamps with HG finish, standard hardware is EG finish. For optional stainless steel hardware, please contact the factory for availability.

PFL037 THRU PFL050T

FLANGE CLAMP

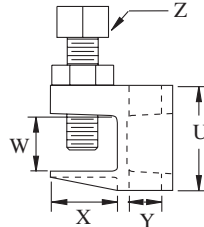
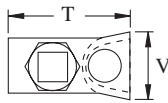
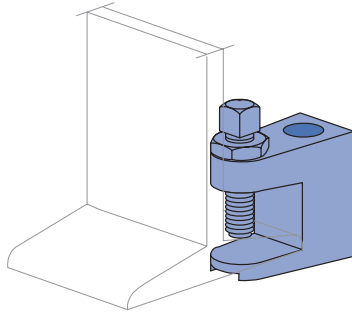

Material: Malleable Iron.

Cup point set screw and lock nut included.

Set Screw Torque = 6 Ft-Lb
Lock Nut Torque = 16 Ft-Lb

Safety Factor: 5

| Part Number | Type of Hole | Rod Size | "Z" Set Screw Size | Wt/100 pcs Lbs (kg) | Max. Allowable Load Lbs (kN) |
|-------------|--------------|----------|--------------------|---------------------|------------------------------|
| PFL037 | Clear | 3/8" | 3/8" | 28 (12.7) | 540 (2.40) |
| PFL037T | Tapped | 3/8" | 3/8" | 28 (12.7) | 540 (2.40) |
| PFL050 | Clear | 1/2" | 3/8" | 40 (18.1) | 700 (3.11) |
| PFL050T | Tapped | 1/2" | 3/8" | 40 (18.1) | 700 (3.11) |

| Part Number | Dimensions | | | | | | |
|-------------|-------------|-------------|-------------|-------------|-------------|-------------|-------------|
| | "T" In (mm) | "U" In (mm) | "V" In (mm) | "W" In (mm) | "X" In (mm) | "Y" In (mm) | |
| PFL037 | 1 1/16 | 1 3/16 | 7/8 | 3/4 | 1 | 7/16 | |
| | 43 | 40 | 22 | 19 | 25 | 11 | |
| PFL037T | 1 1/16 | 1 3/16 | 7/8 | 3/4 | 1 | 3/8 | Tapped Hole |
| | 43 | 40 | 22 | 19 | 25 | | |
| PFL050 | 2 | 1 23/32 | 1 | 29/32 | 1 13/32 | 9/16 | |
| | 51 | 44 | 25 | 23 | 28 | 14 | |
| PFL050T | 2 | 1 23/32 | 1 | 29/32 | 1 1/2 | 1/2 | Tapped Hole |
| | 51 | 44 | 25 | 23 | 28 | | |

PLF3037 THRU PLF3075

FLANGE CLAMP

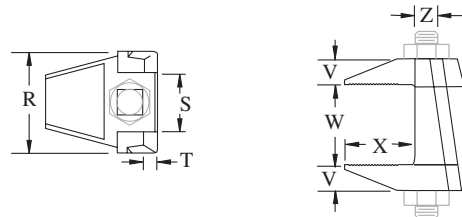
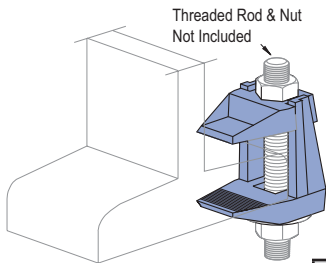

Safety Factor: 4

Material: Malleable Iron.

| Part Number | Rod Size | Wt/100 pcs Lbs (kg) | Max. Allowable Load Lbs (kN) | Torque Ft-Lbs |
|-------------|----------|---------------------|------------------------------|---------------|
| PLF3037 | 3/8" | 53 | 270 | 15 |
| | | 24 | 1.20 | |
| PLF3050 | 1/2" | 91 | 450 | 29 |
| | | 41 | 2.00 | |
| PLF3062 | 5/8" | 186 | 900 | 69 |
| | | 84 | 4.00 | |
| PLF3075 | 3/4" | 334 | 1,350 | 130 |
| | | 152 | 6.01 | |

| Part Number | Dimensions | | | | | |
|-------------|-------------|-------------|-------------|-------------|-------------|-------------|
| | "X" In (mm) | "W" In (mm) | "V" In (mm) | "T" In (mm) | "R" In (mm) | "S" In (mm) |
| PLF3037 | 1 | 0 - 1 1/16 | 3/8 | 9/32 | 1 1/2 | 7/8 |
| | 25 | 0 - 30 | 10 | 7 | 38 | 22 |
| PLF3050 | 1 3/8 | 0 - 1 3/16 | 1/2 | 1 1/32 | 1 15/16 | 1 1/32 |
| | 35 | 0 - 40 | 13 | 9 | 49 | 29 |
| PLF3062 | 1 13/16 | 0 - 2 3/16 | 5/8 | 1/2 | 2 1 1/2 | 1 1/16 |
| | 46 | 0 - 56 | 16 | 13 | 60 | 37 |
| PLF3075 | 2 3/16 | 0 - 1 3/4 | 3/4 | 5/8 | 3 | 1 3/4 |
| | 56 | 0 - 45 | 19 | 16 | 76 | 45 |

PLF9037 THRU PLF9100

FLANGE CLAMP

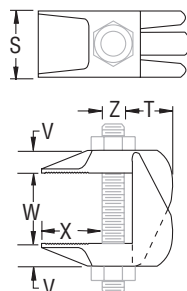
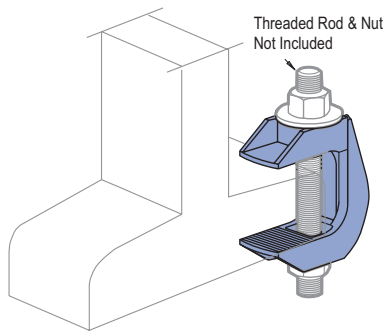

Material: Malleable Iron.

Safety Factor: 5

| Part Number | Rod Size | Wt/100 pcs Lbs (kg) | Max. Allowable Load Lbs (kN) | Torque Ft-Lbs | "X" | "W" | "V" | "T" | "S" |
|-------------|----------|---------------------|------------------------------|---------------|---------|---------------|---------|---------|---------|
| | | | | | In (mm) | In (mm) | In (mm) | In (mm) | In (mm) |
| PLF9037 | 3/8" | 55 | 440 | 15 | 1 | 3/4 - 1 1/16 | 1/2 | 3/4 | 1 |
| | | 24.9 | 1.96 | | 25 | 19 - 43 | 13 | 19 | 25 |
| PLF9050 | 1/2" | 122 | 630 | 29 | 1 3/8 | 1 - 2 3/8 | 2 1/2 | 1 5/16 | 1 3/16 |
| | | 55.3 | 2.80 | | 35 | 25 - 60 | 17 | 24 | 30 |
| PLF9062 | 5/8" | 200 | 1,260 | 69 | 1 11/16 | 1 1/8 - 2 3/4 | 1 3/16 | 1 1/8 | 1 3/8 |
| | | 90.7 | 5.60 | | 43 | 29 - 70 | 21 | 29 | 35 |
| PLF9075 | 3/4" | 367 | 1,880 | 131 | 2 | 1 1/4 - 3 1/4 | 1 | 1 3/8 | 1 3/4 |
| | | 166.5 | 8.36 | | 51 | 32 - 183 | 25 | 35 | 45 |
| PLF9100 | 1" | 1,101 | 3,150 | 173 | 3 | 1 3/4 - 3 3/4 | 1 1/2 | 2 1/16 | 2 1/2 |
| | | 499.4 | 14.01 | | 76 | 45 - 95 | 38 | 56 | 64 |

Note: When used for mechanical supports, load capacities of brackets and fittings should be in compliance with the American Standard Code for Pressure Piping. Clamps are designed to be used with W, M, S & HP Shape beams, Standard C & Misc. MC Channels, Angles & Structural Tees. Clamps must be used in pairs where indicated. For beam clamps with HG finish, standard hardware is EG finish. For optional stainless steel hardware, please contact the factory for availability.

1 5/8" Channel
Telesrnut System
Nuts & Hardware
General Fittings
Pipe/Conduit Supports
Flange Clamp
Electrical Fittings
Concrete Inserts
1 1/2" Framing System
1 3/16" Framing System
Fiberglass System
Special Metals
PrimeAngle System
Product Index



P1834

CHANNEL TROLLEY SUPPORT

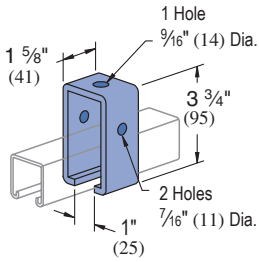

Requires 3/8" x 2 1/2" Bolt and 3/8" Nut (not included)

| |
|--------------------|
| Design Load |
| 1200 Lbs (5.34 kN) |

Wt/100 pcs: 102 Lbs (46.3 kg)

P1834A

CHANNEL TROLLEY SUPPORT

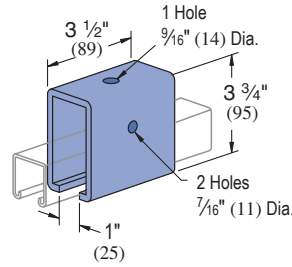

Requires 3/8" x 2 1/2" Bolt and 3/8" Nut (not included)

| |
|---------------------|
| Design Load |
| 2500 Lbs (11.12 kN) |

Wt/100 pcs: 220 Lbs (99.8 kg)

P2749*, P2749N†

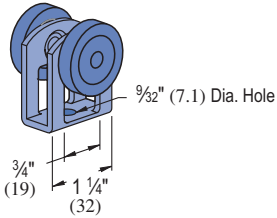

Clevis Material: 12 gauge.

*Wheel bearings are stainless steel, and should not be lubricated.

† "N" indicates acetal wheels.

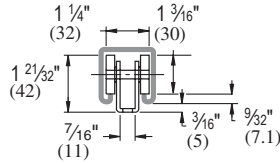

| Part Number | Design Load Lbs (kN) | Wt/100 pcs Lbs (kg) |
|-------------|----------------------|---------------------|
| P2749 | 50 .22 | 21 9.5 |
| P2749N | 10 .04 | 13 5.9 |

P2751*, P2751 N†

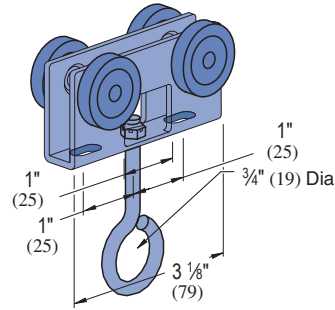

Clevis Material: 12 gauge.

*Wheel bearings are stainless steel, and should not be lubricated.

† "N" indicates acetal wheels.

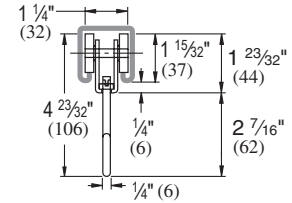

| Part Number | Design Load Lbs (kN) | Wt/100 pcs Lbs (kg) |
|-------------|----------------------|---------------------|
| P2751 | 100 .44 | 63 28.6 |
| P2751N | 20 .09 | 40 18.1 |

P2750*, P2750N†

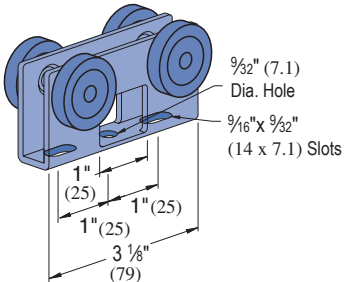

Clevis Material: 12 gauge.

*Wheel bearings are stainless steel, and should not be lubricated.

† "N" indicates acetal wheels.

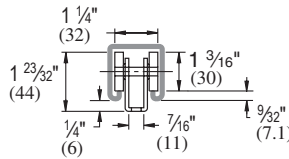

| Part Number | Design Load Lbs (kN) | Wt/100 pcs Lbs (kg) |
|-------------|----------------------|---------------------|
| P2750 | 100 .44 | 55 24.9 |
| P2750N | 20 .09 | 32 14.5 |

P2950

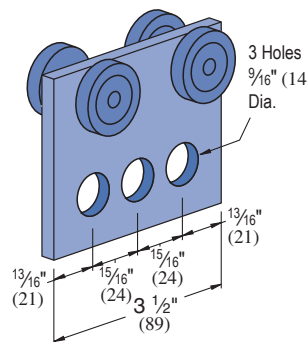

Wheel bearings are stainless steel. Do not lubricate.

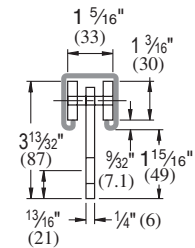

| FPM | RPM | Design Load In P1000 Lbs (kN) |
|-----|-----|-------------------------------|
| 180 | 600 | 300 |
| 180 | 600 | 1.33 |
| 90 | 300 | 450 |
| 90 | 300 | 2.00 |
| 30 | 100 | 600 |
| 30 | 100 | 2.67 |

P2949

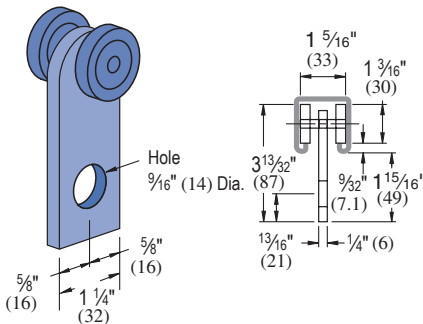

| Design Load In P1000 | | |
|----------------------|-----|-------------|
| FPM | RPM | Lbs (kN) |
| 180 | 600 | 150 .67 |
| 90 | 300 | 225 1.00 |
| 30 | 100 | 437 1.94 |

Wheel bearings are stainless steel. Do not lubricate.

Wt/100 pcs: 46 Lbs (20.9 kg)

Wt/100 pcs: 110 Lbs (49.9 kg)

Standard Dimensions for 1 5/8" (41mm) width series channel fittings (Unless Otherwise Shown on Drawing)

Hole Diameter: 9/16" (14mm); Hole Spacing - From End: 13/16" (21mm); Hole Spacing - On Center: 1 7/8" (48mm); Width: 1 5/8" (41mm); Thickness: 1/4" (6mm)

P2354 R-L, P2355 R-L

REEL RACK SUPPORTS FOR 1 1/4" & 2" PIPE

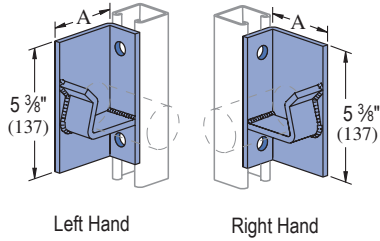

| Vertical Channel | Max. Allowable Load |
|------------------|---------------------|
| Part No. Gauge | Lbs (kN) |
| P1000 12 | 3,000 (13.34) |
| P1100 14 | 2,000 (8.90) |
| P2000 16 | 2,000 (8.90) |

| Part Number | "A" In (mm) | Std. Pipe Size In (mm) | Wt/100 pcs Lbs (kg) |
|-------------|-------------|------------------------|---------------------|
| P2354 R-L | 3 | 1 1/4 | 220 |
| | 76 | 32 | 99.8 |
| P2355 R-L | 3 5/8 | 2 | 252 |
| | 92 | 52 | 114.3 |

P1204 THRU P1208

WALL LADDER BRACKET

P2454

DOUBLE PIPE AXLE SUPPORT

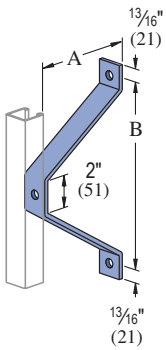

| Part Number | "A" In (mm) | "B" In (mm) | Wt/100 pcs Lbs (kg) |
|-------------|---------------|-------------|---------------------|
| P1204 | 2 1/2 60 | 6 152 | 113 51.3 |
| P1205 | 4 3/8 111 | 8 203 | 164 74.4 |
| P1206 | 6 3/8 162 | 10 254 | 216 98.0 |
| P1207 | 8 3/8 213 | 12 305 | 267 121.1 |
| P1208 | 10 3/8 264 | 14 356 | 318 144.2 |

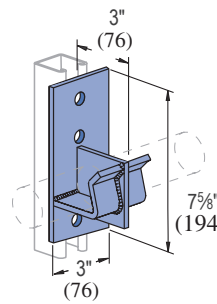

Load Rating 4,000 Lbs (17.79 kN)

For 1 1/4" (32) Standard Pipe

Wt/100 pcs: 310 Lbs (140.6 kg)

P1201, P1202, P1203

LADDER RUNG

P2470-50, -75, -100

PIPE COUPLING FITTING

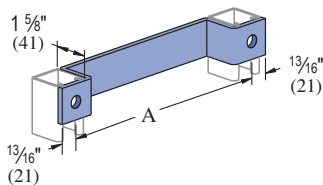

| Part Number | "A" In (mm) | Wt/100 pcs Lbs (kg) |
|-------------|-------------|---------------------|
| P1201 | 12 305 | 186 84.4 |
| P1202 | 15 381 | 221 100.2 |
| P1203 | 18 457 | 254 115.2 |

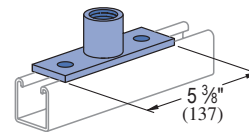

| Pipe Coupling | | |
|---------------|---------|---------------------|
| Part Number | Size In | Wt/100 pcs Lbs (kg) |
| P2470-50 | 1/2 | 77 (34.9) |
| P2470-75 | 3/4 | 93 (42.2) |
| P2470-100 | 1 | 103 (46.7) |

P1944

45° (.25π) STAIR TREAD SUPPORT

P2655

37 1/2° (.21π) STAIR TREAD SUPPORT

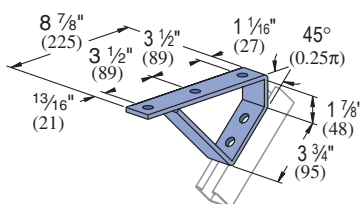

Wt/100 pcs: 220 Lbs (99.8 kg)

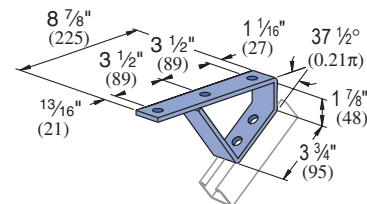

Wt/100 pcs: 213 Lbs (96.6 kg)

Standard Dimensions for 1 1/2" (41mm) width series channel fittings (Unless Otherwise Shown on Drawing)

Hole Diameter: 9/16" (14mm); Hole Spacing - From End: 13/16" (21mm); Hole Spacing - On Center: 1 7/8" (48mm); Width: 1 1/2" (41mm); Thickness: 1/4" (6mm)

Note : When used for mechanical supports, load capacities of brackets and fittings should be in compliance with the American Standard Code for Pressure Piping.



P1843 ADJ. HINGE CONNECTION

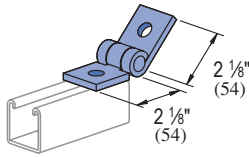

Wt/100 pcs: 68 Lbs (30.8 kg)

P1354A ADJ. HINGE CONNECTION

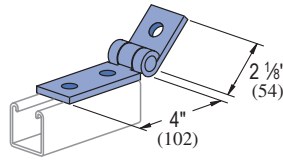

Wt/100 pcs: 89 Lbs (40.4 kg)

P1354 ADJ. HINGE CONNECTION

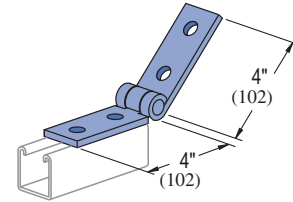

Wt/100 pcs: 109 Lbs (49.4 kg)

SPF® 100

SEISMIC PIVOT FITTINGS

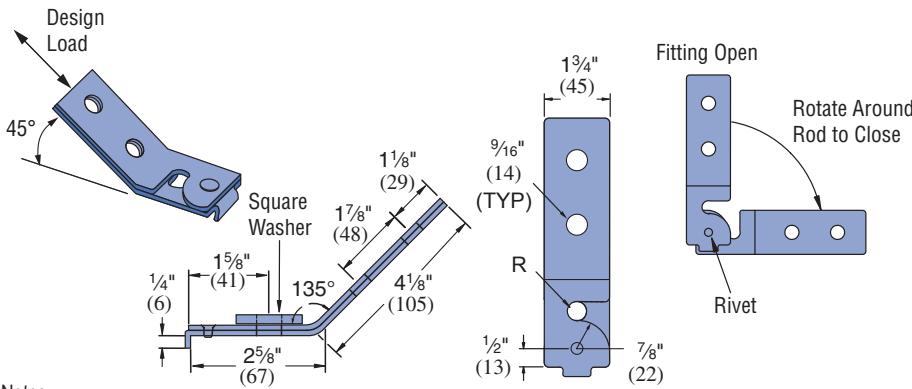

Notes:

1. Design load is limited to slip capacity of a channel nut at hole "R".
2. Allowable loads have been determined by the manufacturers testing, analysis and technical specifications.
3. For retrofit application, engineer of record must verify.
4. Patented.
5. Square washer provided with fitting.
6. When a hanger rod is thru-bolted (in lieu of channel nut installation), higher transverse loads may be transmitted due to the higher allowed rod shear loads compared to channel nut slip values. This higher load may be used with verification through engineering calculations.

| Part Number | Rod Size In (mm) | "R" - Hole Diameter In (mm) | Design Load Lbs (KN) |
|-------------|------------------|-----------------------------|----------------------|
| SPF 100-037 | 3/8 10 | 7/16 11 | 1,400 6.23 |
| SPF 100-050 | 1/2 13 | 9/16 14 | 2,100 9.34 |
| SPF 100-062 | 5/8 16 | 11/16 18 | 2,100 9.34 |
| SPF 100-075 | 3/4 19 | 13/16 21 | 2,400 10.68 |

Safety Factor = 3.0

FINISH

Electro-galvanized (EG), conforming to ASTM B633 Type III SC1.

SPF® 200

ADJUSTABLE SEISMIC PIVOT FITTINGS

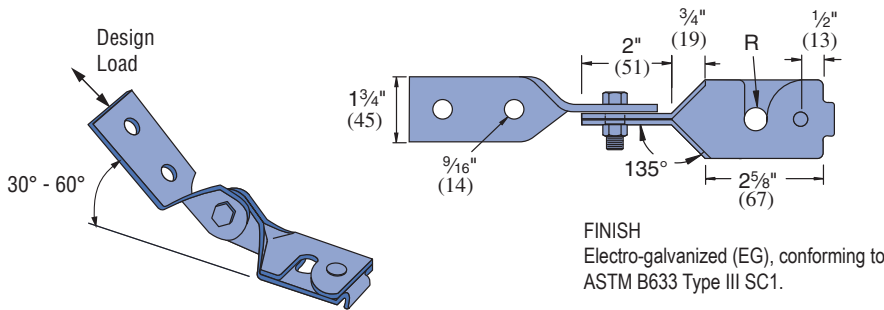

FINISH
Electro-galvanized (EG), conforming to ASTM B633 Type III SC1.

| Part Number | Rod Size In (mm) | "R" - Hole Diameter In (mm) | Design Load Lbs (KN) |
|-------------|------------------|-----------------------------|----------------------|
| SPF 200-037 | 3/8 10 | 7/16 11 | 1,400 6.23 |
| SPF 200-050 | 1/2 13 | 9/16 14 | 2,100 9.34 |
| SPF 200-062 | 5/8 16 | 11/16 18 | 2,100 9.34 |
| SPF 200-075 | 3/4 19 | 13/16 21 | 2,400 10.68 |

Safety Factor = 3.0

Notes:

1. Design load is limited to slip capacity of a channel nut at hole "R".
2. Allowable loads have been determined by the manufacturers testing, analysis and technical specifications at 45° from horizontal.
3. For retrofit application, engineer of record must verify.
4. Patented.
5. Square washer provided with fitting.
6. When a hanger rod is thru-bolted (in lieu of channel nut installation), higher transverse loads may be transmitted due to the higher allowed rod shear loads compared to channel nut slip values. This higher load may be used with verification through engineering calculations.

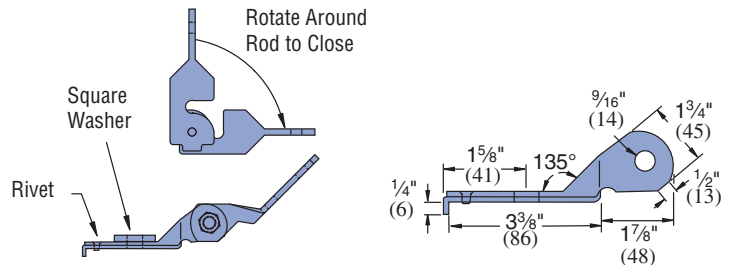

1 5/8" Channel
 Telestrut System
 Nuts & Hardware
 General Fittings
 Pipe/Conduit Supports
 Electrical Fittings
 Concrete Inserts
 1 1/4" Framing System
 1 3/16" Framing System
 Fiberglass System
 Special Metals
 PrimeAngle System
 Product Index

SPF® 300

SEISMIC PIVOT FITTINGS

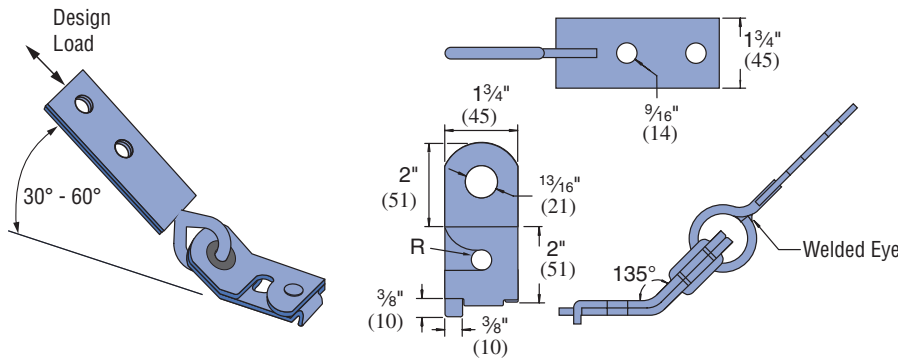

| Part Number | Rod Size In (mm) | "R" - Hole Diameter In (mm) | Design Load Lbs (kN) |
|-------------|------------------|-----------------------------|----------------------|
| SPF 300-037 | 3/8 10 | 7/16 11 | 1,400 6.23 |
| SPF 300-050 | 1/2 13 | 9/16 14 | 2,100 9.34 |
| SPF 300-062 | 5/8 16 | 11/16 18 | 2,100 9.34 |
| SPF 300-075 | 3/4 19 | 13/16 21 | 2,400 10.68 |

Safety Factor = 3.0
FINISH
Electro-galvanized (EG), conforming to ASTM B633 Type III SC1.

Notes:

- Design load is limited to slip capacity of a channel nut at hole "R".
- Allowable loads have been determined by the manufacturers testing, analysis and technical specifications at 45° from horizontal.
- For retrofit application, engineer of record must verify.
- Patented.
- Square washer provided with fitting.
- When a hanger rod is thru-bolted (in lieu of channel nut installation), higher transverse loads may be transmitted due to the higher allowed rod shear loads compared to channel nut slip values. This higher load may be used with verification through engineering calculations.



SPF® 400

SEISMIC PIVOT FITTINGS

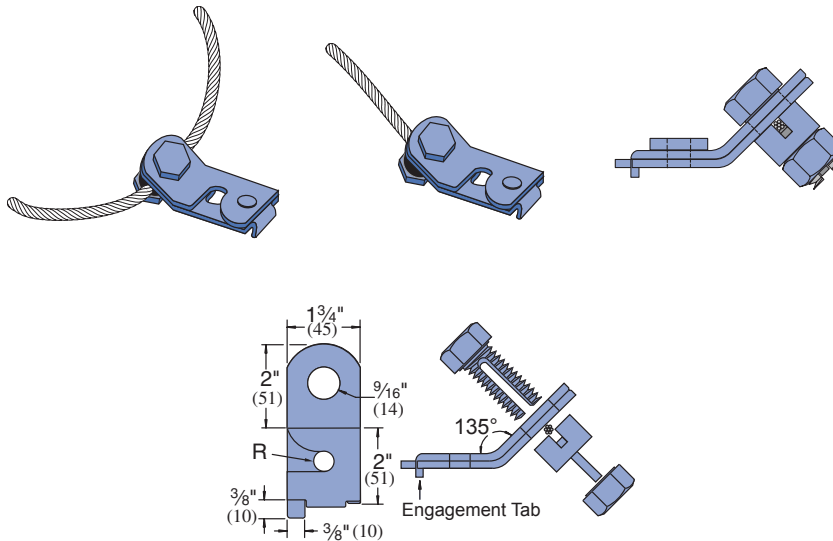

| Part Number | Rod Size In (mm) | "R" - Hole Diameter In (mm) |
|-------------|------------------|-----------------------------|
| SPF 400-037 | 3/8 10 | 7/16 11 |
| SPF 400-050 | 1/2 13 | 9/16 14 |
| SPF 400-062 | 5/8 16 | 11/16 18 |
| SPF 400-075 | 3/4 19 | 13/16 21 |

FINISH
Electro-galvanized (EG), conforming to ASTM B633 Type III SC1.

| Wire Rope Diameter In (mm) | Horizontal Design Load | | |
|----------------------------|------------------------|-----------------------|-------------------------|
| | 4-Way Splayed | | Single Cable Transverse |
| | Transverse lbs (kN) | Longitudinal lbs (kN) | lbs (kN) |
| 3/16 | 1050 | 1116 | 650 |
| 5 | 4.67 | 4.96 | 2.89 |

Notes:

- Allowable loads have been determined by the manufacturers testing, analysis and technical specifications.
- Galvanized wire rope, 7 x 19 IWSC, RHRL (Prestretched).
- Torque on nut/spacer: 50 ft-lbs.
- Safety Factor of 3 for prestretched cable..

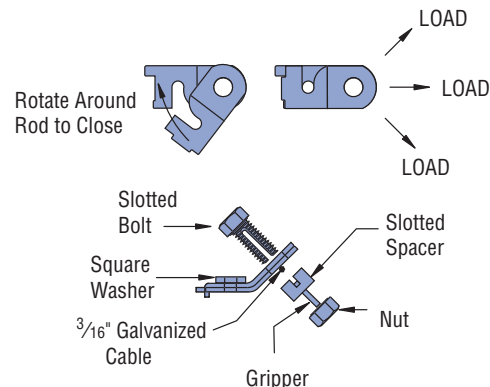

1 1/2" Channel
Telesnut System
Nuts & Hardware
General Fittings
Pipe/Conduit Supports
Electrical Fittings
Concrete Inserts
1 1/2" Framing System
1 3/16" Framing System
Fiberglass System
Special Metals
PrimeAngle System
Product Index



LS 410

SEISMIC PIVOT FITTINGS

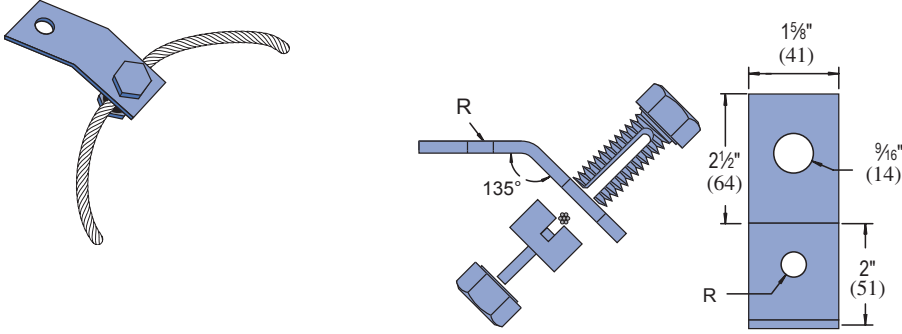

| Part Number | Anchor Size In (mm) | "R" - Hole Diameter In (mm) |
|-------------|---------------------|-----------------------------|
| LS 410-037 | 3/8 10 | 7/16 11 |
| LS 410-050 | 1/2 13 | 9/16 14 |
| LS 410-062 | 5/8 16 | 11/16 18 |
| LS 410-075 | 3/4 19 | 13/16 21 |

FINISH

Electro-galvanized (EG), conforming to ASTM B633 Type III SC1.

Note:

1. Allowable loads have been determined by the manufacturers testing, analysis and technical specifications.
2. For retrofit application, engineer of record must verify.
3. Torque on nut/spacer: 50 ft-lbs.
4. Square washer provided with fitting.
5. Loads are the same as the SPF 400

LS 500

SEISMIC PIVOT FITTINGS

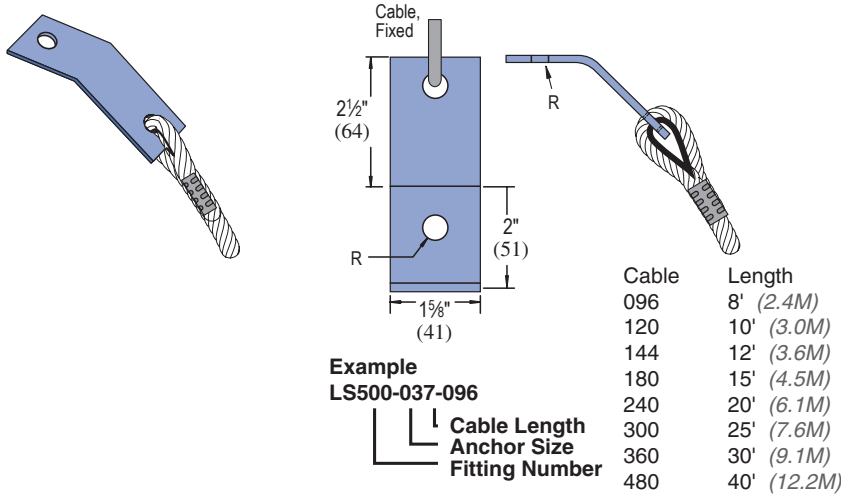

| Part Number | Anchor Size In (mm) | "R" - Hole Diameter In (mm) |
|-------------|---------------------|-----------------------------|
| LS 500-037 | 3/8 10 | 7/16 11 |
| LS 500-050 | 1/2 13 | 9/16 14 |
| LS 500-062 | 5/8 16 | 11/16 18 |
| LS 500-075 | 3/4 19 | 13/16 21 |

FINISH

Electro-galvanized (EG), conforming to ASTM B633 Type III SC1.

Note:

1. Allowable loads have been determined by the manufacturers testing, analysis and technical specifications.
2. For retrofit application, engineer of record must verify.
3. Patented
4. Square washer provided with fitting.
5. Loads are the same as the SPF 400



PIPE/CONDUIT SUPPORTS

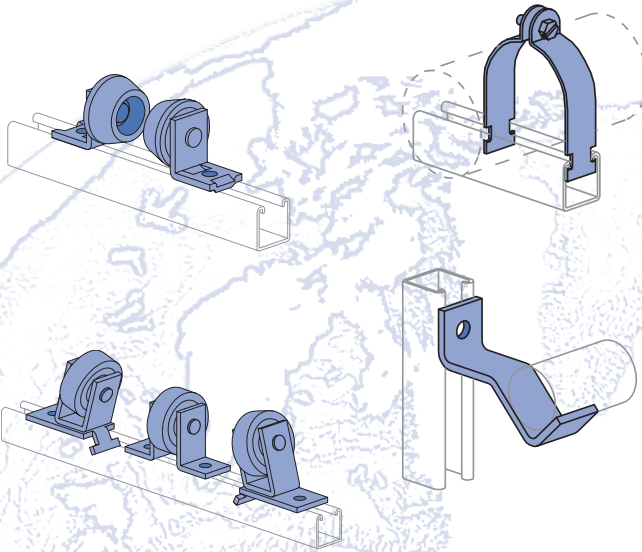

Pipe/Conduit Clamps 102-105

Unicushion® 106

Pipe & Tubing (Cush-A-Clamp®) Clamps 107-110

Pipe Hangers 111

Pipe Rollers 111-112

Pipe Brackets 113

Reference Tables 114-120

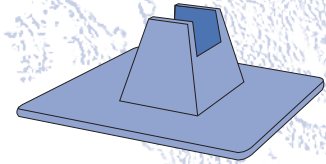
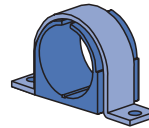

MATERIAL

Unistrut pipe clamps, unless noted, are punch-press made from hot-rolled, pickled and oiled steel plates, strip or coil, and conform to ASTM specifications A1008, A575, A576, A635, or A36. The fitting steel also meets the physical requirements of ASTM A1011 SS GR 33. The pickling of the steel produces a smooth surface free from scale.

Many items are also available in stainless steel.

Consult factory for ordering information.

FINISHES

Pipe supports are available in:

- Electro-galvanized (EG), conforming to ASTM B633 Type III SC1
- Hot-dipped galvanized (HG), conforming to ASTM A123 or A153 (hardware)
- Perma-Green III (GR), and plain (PL).

APPLICATION

Unistrut pipe clamps, pipe hangers, brackets and rollers are designed for the support of electrical and mechanical services. Supports to meet nearly every requirement can be attained using Unistrut Metal Framing components.

DIMENSIONS

Imperial dimensions are illustrated in inches. Metric dimensions are shown in parenthesis or as noted. Unless noted, all metric dimensions are in millimeters and rounded to one decimal place.

DESIGN BOLT TORQUE

| BOLT SIZE | 1/4"-20 | 5/16"-18 | 3/8"-16 | 1/2"-13 | 5/8"-11 | 3/4"-10 |
|----------------------------|----------|------------|------------|------------|--------------|--------------|
| Rec.Torque Ft/Lbs (N*m) | 6 (8) | 11 (15) | 19 (26) | 50 (68) | 100 (136) | 125 (170) |
| Max Torque Ft/Lbs (N*m) | 7 (9) | 15 (20) | 25 (34) | 70 (95) | 125 (170) | 135 (183) |

Note: When tightening 1/4" screws used with a two piece pipe clamp, a torque of 5 foot pounds (60 inch-pounds) should be used.

DESIGN LOAD

Design load data, where shown, is based on the ultimate strength of the connection with a safety factor of 5.0, unless otherwise noted.

Pipe Clamps In Special Materials (P1109, P1211, P1425, P2024 Series)

| Material | Add Suffix to P/N | Example |
|--------------------------------------|-------------------|----------|
| Steel Strap, Everdur Hardware | E | P1109 E |
| Copper Coated Steel Strap & Hardware | CC | P1109 CC |
| Aluminum Material: Malleable Iron. | AL | P1109 AL |
| Stainless Steel 304 or 316 | SS or ST | P1109 SS |
| Plastic Coated Steel Straps | PC | P1109 PC |



Pipe & Conduit Clamps

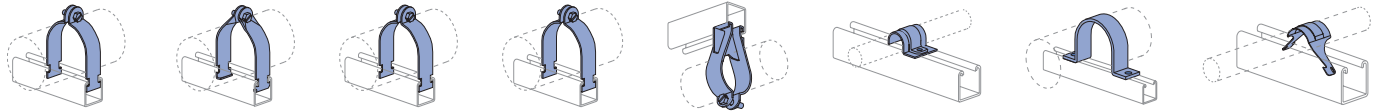

P1109 - Pg 102

P1211 - Pg 103

P1425 - Pg 103

P2024 - Pg 104

P1563 - Pg 103

P2008 - Pg 103

P2558 - Pg 104

P2609 - Pg 104

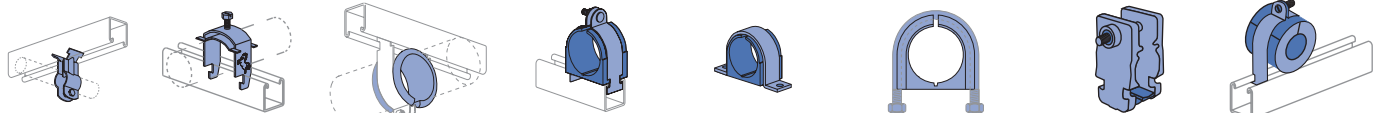

P3409 - Pg 105

MU025 - Pg 105

P2600 - Pg 106

004T008 - Pg 107

004M007 - Pg 108

UB1/2PA - Pg 109

CG-10 - Pg 110

PUX3834 - Pg 110

Pipe Rollers

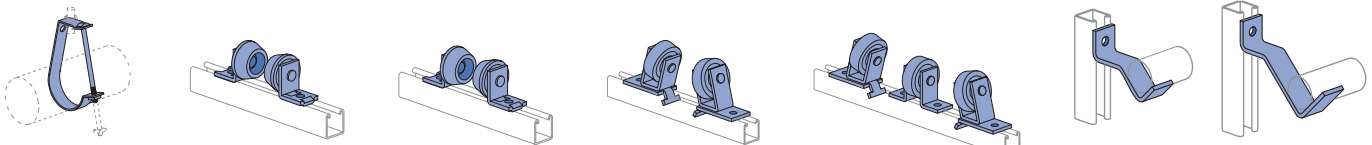

J1205 - Pg 111

P2474 - Pg 111

P2474-1 - Pg 112

P2475 - Pg 112

P2476 - Pg 112

P2481 - Pg 113

P2482 - Pg 113



P2243 - Pg 113

UP-BK - Pg 113

Pipe Brackets

P1109 THRU P1126

PIPE CLAMPS FOR RIGID STEEL CONDUIT

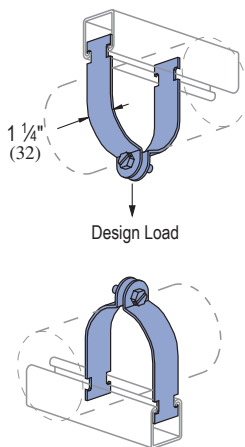

| Part No. | Conduit Size In | O.D. Size In (mm) | Thickness Gauge (mm) | Wt/100 pcs Lbs (kg) | Design Load Lbs (kN) |
|----------|-----------------|-------------------|----------------------|---------------------|----------------------|
| P1109 | 3/8 | 0.675 | 16 | 10 | 400 |
| | | 17.1 | 1.5 | 4.5 | 1.78 |
| P1111 | 1/2 | 0.840 | 16 | 11 | 400 |
| | | 21.3 | 1.5 | 5.0 | 1.78 |
| P1112 | 3/4 | 1.050 | 14 | 15 | 600 |
| | | 26.7 | 1.9 | 6.8 | 2.67 |
| P1113 | 1 | 1.315 | 14 | 17 | 600 |
| | | 33.4 | 1.9 | 7.7 | 2.67 |
| P1114 | 1 1/4 | 1.660 | 14 | 19 | 600 |
| | | 42.2 | 1.9 | 8.6 | 2.67 |
| P1115 | 1 1/2 | 1.900 | 12 | 29 | 800 |
| | | 48.3 | 2.7 | 13.2 | 3.56 |
| P1117 | 2 | 2.375 | 12 | 34 | 800 |
| | | 60.3 | 2.7 | 15.4 | 3.56 |

| Part No. | Conduit Size In | O.D. Size In (mm) | Thickness Gauge (mm) | Wt/100 pcs Lbs (kg) | Design Load Lbs (kN) |
|----------|-----------------|-------------------|----------------------|---------------------|----------------------|
| P1118 | 2 1/2 | 2.875 | 12 | 40 | 800 |
| | | 73.0 | 2.7 | 18.1 | 3.56 |
| P1119 | 3 | 3.500 | 12 | 47 | 800 |
| | | 88.9 | 2.7 | 21.3 | 3.56 |
| P1120 | 3 1/2 | 4.000 | 11 | 62 | 1,000 |
| | | 101.6 | 3.0 | 28.1 | 4.45 |
| P1121 | 4 | 4.500 | 11 | 67 | 1,000 |
| | | 114.3 | 3.0 | 30.4 | 4.45 |
| P1123 | 5 | 5.563 | 11 | 80 | 1,000 |
| | | 141.3 | 3.0 | 36.3 | 4.45 |
| P1124 | 6 | 6.625 | 10 | 102 | 1,000 |
| | | 168.3 | 3.4 | 46.3 | 4.45 |
| P1126 | 8 | 8.625 | 10 | 130 | 1,000 |
| | | 219.1 | 3.4 | 59.0 | 4.45 |

Slotted hex head screw and nut included with EG or HG Finish.

1 1/2" Channel
 Telestrut System
 Nuts & Hardware
 General Fittings
 Pipe/Conduit Supports
 Electrical Fittings
 Concrete Inserts
 1 1/4" Framing System
 1 3/16" Framing System
 Fiberglass System
 Special Metals
 PrimeAngle System
 Product Index

P1425 THRU P1431

PIPE CLAMPS FOR THIN WALL CONDUIT (E.M.T.)

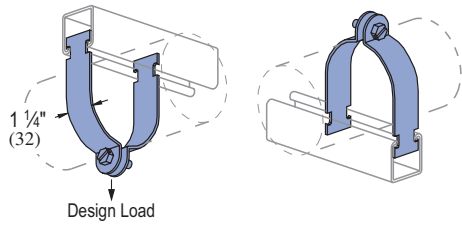

Slotted hex head screw and nut included with EG or HG Finish.

| Part No. | Conduit Size In (mm) | O.D. Size In (mm) | Thickness Gauge (mm) | Wt/100 pcs Lbs (kg) | Design Load Lbs (kN) |
|----------|----------------------|-------------------|----------------------|---------------------|----------------------|
| P1425 | 3/8 10 | 0.577 14.7 | 16 1.5 | 9 4.1 | 400 1.78 |
| P1426 | 1/2 13 | 0.706 17.9 | 16 1.5 | 11 5.0 | 400 1.78 |
| P1427 | 3/4 19 | 0.922 23.4 | 16 1.5 | 12 5.4 | 400 1.78 |
| P1428 | 1 25 | 1.163 29.5 | 14 1.9 | 15 6.8 | 600 2.67 |
| P1429 | 1 1/4 32 | 1.510 38.4 | 14 1.9 | 18 8.2 | 600 2.67 |
| P1430 | 1 1/2 38 | 1.740 44.2 | 12 2.7 | 29 13.2 | 800 3.56 |
| P1431 | 2 51 | 2.197 55.8 | 12 2.7 | 33 15.0 | 800 3.56 |
| P1118 | 2 1/2 64 | 2.875 73.0 | 12 2.7 | 40 18.1 | 800 3.56 |
| P1119 | 3 76 | 3.500 88.9 | 12 2.7 | 47 21.3 | 800 3.56 |
| P1120 | 3 1/2 89 | 4.000 101.6 | 11 3.0 | 62 28.1 | 1,000 4.45 |
| P1121 | 4 102 | 4.500 114.3 | 11 3.0 | 67 30.4 | 1,000 4.45 |

P1211 THRU P1217

UNIVERSAL CLAMPS FOR RIGID OR THINWALL CONDUIT

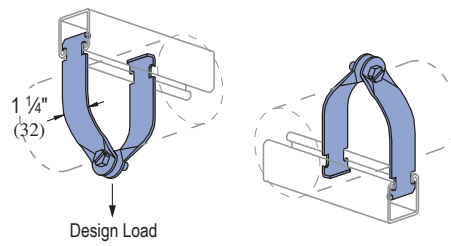

Slotted hex head screw and nut included with EG or HG Finish.

| Part No. | Conduit Size In (mm) | Thickness Gauge (mm) | Wt/100 pcs Lbs (kg) | Design Load Lbs (kN) |
|----------|----------------------|----------------------|---------------------|----------------------|
| P1211 | 1/2 13 | 16 1.5 | 10 4.5 | 400 1.78 |
| P1212 | 3/4 19 | 16 1.5 | 11 5.0 | 400 1.78 |
| P1213 | 1 25 | 16 1.5 | 12 5.4 | 400 1.78 |
| P1214 | 1 1/4 32 | 14 1.9 | 18 8.2 | 600 2.67 |
| P1215 | 1 1/2 38 | 14 1.9 | 20 9.1 | 600 2.67 |
| P1217 | 2 51 | 14 1.9 | 22 10.0 | 600 2.67 |

P1563 THRU P1573

PARALLEL CLAMPS FOR RIGID CONDUIT AND PIPE

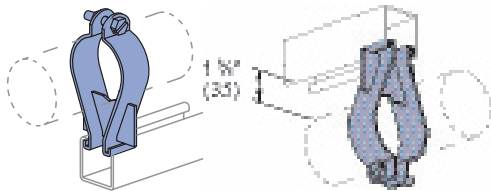

Slotted hex head screw and nut included.

Finish: Electro-galvanized.

| Part No. | Pipe Size In (mm) | O.D. Size In (mm) | Thickness Gauge (mm) | Wt/100 pcs Lbs (kg) |
|----------|-------------------|-------------------|----------------------|---------------------|
| P1563 | 3/8 10 | 0.675 17.1 | 14 1.9 | 27 12.2 |
| P1564 | 1/2 13 | 0.840 21.3 | 14 1.9 | 29 13.2 |
| P1565 | 3/4 19 | 1.050 26.7 | 14 1.9 | 30 13.6 |
| P1566 | 1 25 | 1.315 33.4 | 14 1.9 | 31 14.1 |
| P1567 | 1 1/4 32 | 1.660 42.2 | 14 1.9 | 38 17.2 |
| P1568 | 1 1/2 38 | 1.900 48.3 | 12 2.7 | 40 18.1 |
| P1569 | 2 51 | 2.375 60.3 | 12 2.7 | 47 21.3 |
| P1570 | 2 1/2 64 | 2.875 73.0 | 12 2.7 | 66 29.9 |
| P1571 | 3 76 | 3.500 88.9 | 12 2.7 | 78 35.4 |
| P1572 | 3 1/2 89 | 4.000 101.6 | 12 2.7 | 87 39.5 |
| P1573 | 4 102 | 4.500 114.3 | 12 2.7 | 90 40.8 |

P2008 THRU P2020

ONE HOLE CLAMP FOR O.D. TUBING

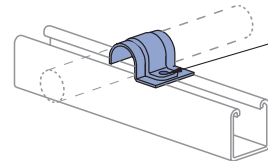

1/4" X 3/4" Round Head Machine Screw and Channel Nut Not Included

Finish: Electro-galvanized and Aluminum

| Part No. | O.D. Tube Size In (mm) | Thickness Gauge (mm) | Wt/100 pcs Lbs (kg) |
|----------|------------------------|----------------------|---------------------|
| P2008 | 1/4 6 | 16 1.5 | 4 1.8 |
| P2009 | 5/16 8 | 16 1.5 | 5 2.3 |
| P2010 | 3/8 10 | 16 1.5 | 5 2.3 |
| P2012 | 1/2 13 | 16 1.5 | 6 2.7 |
| P2014 | 5/8 16 | 14 1.9 | 8 3.6 |
| P2016 | 3/4 19 | 14 1.9 | 9 4.1 |
| P2018 | 7/8 22 | 14 1.9 | 10 4.5 |
| P2020 | 1 25 | 14 1.9 | 11 5.0 |



P2024 THRU P2070-84

PIPE CLAMPS FOR O.D. TUBING

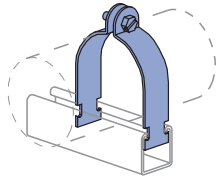

- P2024 - P2029 16 ga.
- P2030 - P2035 14 ga.
- P2037 - P2052 12 ga.
- P2053 - P2066 11 ga.
- P2067 - P2070-84 10 ga.

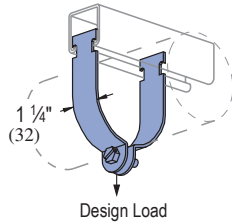

Slotted hex head screw and nut included with EG or HG Finish.

| Part Number | O.D. Size In (mm) | Wt/100 pcs Lbs (kg) | Design Load Lbs (kN) |
|-------------|-------------------|---------------------|----------------------|
| P2024 | 1/4 (6) | 8 (3.6) | 400 (1.78) |
| P2025 | 3/8 (10) | 8 (3.6) | |
| P2026 | 1/2 (13) | 9 (4.1) | |
| P2027 | 5/8 (16) | 10 (4.5) | |
| P2028 | 3/4 (19) | 11 (5.0) | |
| P2029 | 7/8 (22) | 12 (5.4) | 600 (2.67) |
| P2030 | 1 (25) | 14 (6.4) | |
| P2031 | 1 1/8 (29) | 15 (6.8) | |
| P2032 | 1 1/4 (32) | 16 (7.3) | |
| P2033 | 1 3/8 (35) | 17 (7.7) | |
| P2034 | 1 1/2 (38) | 18 (8.2) | 800 (3.56) |
| P2035 | 1 5/8 (41) | 19 (8.6) | |
| P1430 | 1 3/4 (45) | 29 (13.2) | |
| P2037 | 1 7/8 (48) | 28 (12.7) | |
| P2038 | 2 (51) | 31 (14.1) | |
| P2039 | 2 1/8 (54) | 32 (14.5) | |
| P2040 | 2 1/4 (57) | 33 (15) | |
| P1117 | 2 3/8 (60) | 34 (15.4) | |
| P2042 | 2 1/2 (64) | 35 (15.9) | |
| P2043 | 2 5/8 (67) | 37 (16.8) | |
| P2044 | 2 3/4 (70) | 38 (17.2) | |
| P1118 | 2 7/8 (73) | 40 (18.1) | |
| P2046 | 3 (76) | 41 (18.6) | |
| P2047 | 3 1/8 (79) | 43 (19.5) | |
| P2048 | 3 1/4 (83) | 45 (20.4) | |
| P2049 | 3 3/8 (86) | 46 (20.9) | |
| P1119 | 3 1/2 (89) | 47 (21.3) | 1000 (4.45) |
| P2051 | 3 5/8 (92) | 56 (25.4) | |
| P2052 | 3 3/4 (95) | 58 (26.3) | |
| P2053 | 3 7/8 (98) | 60 (27.2) | |
| P1120 | 4 (102) | 62 (28.1) | |
| P2055 | 4 1/8 (105) | 62 (28.1) | |
| P2056 | 4 1/4 (108) | 64 (29.0) | |
| P2057 | 4 3/8 (111) | 66 (29.9) | |
| P1121 | 4 1/2 (114) | 67 (30.4) | |
| P2059 | 4 5/8 (118) | 70 (31.8) | |
| P2060 | 4 3/4 (121) | 72 (32.7) | |

| Part Number | O.D. Size In (mm) | Wt/100 pcs Lbs (kg) | Design Load Lbs (kN) |
|-------------|-------------------|---------------------|----------------------|
| P2061 | 4 7/8 (124) | 73 (33.1) | 1000 (4.45) |
| P2062 | 5 (127) | 74 (33.6) | |
| P2063 | 5 1/8 (130) | 76 (34.5) | |
| P2064 | 5 1/4 (133) | 77 (34.9) | |
| P2065 | 5 3/8 (137) | 78 (35.4) | |
| P2066 | 5 1/2 (140) | 79 (35.8) | |
| P2067 | 5 5/8 (143) | 88 (39.9) | |
| P2068 | 5 3/4 (146) | 90 (40.8) | |
| P2069 | 5 7/8 (149) | 92 (41.7) | |
| P2070 | 6 (152) | 94 (42.6) | |
| P2070-61 | 6 1/8 (156) | 96 (43.5) | |
| P2070-62 | 6 1/4 (159) | 98 (44.5) | |
| P2070-63 | 6 3/8 (162) | 99 (44.9) | |
| P2070-64 | 6 1/2 (165) | 100 (45.4) | |
| P1124 | 6 5/8 (168) | 102 (46.3) | |
| P2070-66 | 6 3/4 (172) | 104 (47.2) | |
| P2070-67 | 6 7/8 (175) | 106 (48.1) | |
| P2070-70 | 7 (178) | 108 (49.0) | |
| P2070-71 | 7 1/8 (181) | 110 (49.9) | |
| P2070-72 | 7 1/4 (184) | 112 (50.8) | |
| P2070-73 | 7 3/8 (187) | 114 (51.7) | |
| P2070-74 | 7 1/2 (191) | 116 (52.6) | |
| P2070-75 | 7 5/8 (194) | 117 (53.1) | |
| P2070-76 | 7 3/4 (197) | 119 (54.0) | |
| P2070-77 | 7 7/8 (200) | 121 (54.9) | |
| P2070-80 | 8 (203) | 123 (55.8) | |
| P2070-81 | 8 1/8 (206) | 125 (56.7) | |
| P2070-82 | 8 1/4 (210) | 126 (57.2) | |
| P2070-83 | 8 3/8 (213) | 128 (58.1) | |
| P2070-84 | 8 1/2 (216) | 129 (58.5) | |
| P1126 | 8 5/8 (219) | 130 (59.0) | |

P2558-5 THRU P2558-60

SINGLE PIECE PIPE STRAP

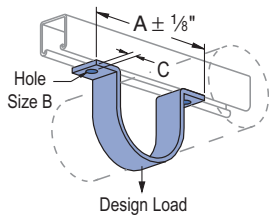

Hardware sold separately.

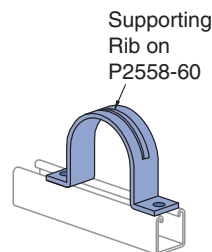

| Part No. | Nom. Pipe Size In | A In (mm) | "B" In (mm) | C In (mm) | Thickness In (mm) | Wt/100 pcs Lbs (kg) | Design Load Lbs (kN) |
|----------|-------------------|--------------|--------------|----------------|-------------------|---------------------|----------------------|
| P2558-05 | 1/2 | 2 1/8 73 | | | | 23 | |
| P2558-07 | 3/4 | 3 1/8 79 | | | | 26 | |
| P2558-10 | 1 | 3 3/8 86 | 9/32 7.1 | 7/16 11.1 | 1/8 3.2 | 31 | 500 |
| P2558-12 | 1 1/4 | 3 3/4 95 | 7/16 11.1 | 1 1/16 17.5 | 1/4 6.4 | 14.1 | 2.22 |
| P2558-15 | 1 1/2 | 3 7/8 98 | | | | 35 | |
| P2558-20 | 2 | 5 3/4 146 | | | | 39 | |
| P2558-25 | 2 1/2 | 6 1/4 159 | | | | 17.7 | |
| P2558-30 | 3 | 6 7/8 175 | | | | 94 | |
| P2558-35 | 3 1/2 | 7 3/8 187 | | | | 42.6 | |
| P2558-40 | 4 | 7 7/8 200 | | | | 114 | |
| P2558-50 | 5 | 9 229 | | | | 51.7 | |
| P2558-60 | 6 | 10 254 | | | | 133 | |
| | | | | | | 60.3 | |
| | | | 152 | | | | |
| | | | 68.9 | | | | |
| | | | 176 | | | | |
| | | | 79.8 | | | | |
| | | | 198 | | | | |
| | | | 89.8 | | | | |
| | | | 225 | | | | |
| | | | 102.1 | | | | |

1 5/8" Channel
 Telestrut System
 Nuts & Hardware
 General Fittings
 Pipe/Conduit Supports
 Electrical Fittings
 Concrete Inserts
 1 1/4" Framing System
 1 3/16" Framing System
 Fiberglass System
 Special Metals
 PrimeAngle System
 Product Index

P3409 THRU P3417

STAND-OFF PIPE CLAMPS

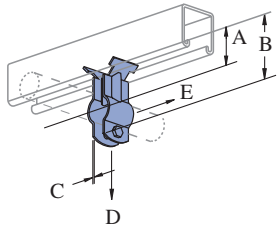

Hardware included.
 Finish: Electro-galvanized.
 Pipe Clamp 1¼" Wide
 Patent No. 3417951.

| Part No. | Pipe Size In (mm) | O.D. Size In (mm) | Load "D" Lbs (kN) | Load "E" Lbs (kN) | A In (mm) | B In (mm) | C Gauge (mm) | Wt/100 pcs Lbs (kg) |
|----------|-------------------|-------------------|-------------------|-------------------|-----------|-----------|--------------|---------------------|
| P3409 | ¾ | 0.675 | 100 | 25 | 1⅞ | 2⅞ | 14 | 14 |
| | 10 | 17.1 | 0.44 | 0.11 | 29 | 54 | 1.9 | 6.4 |
| P3411 | ½ | 0.840 | 150 | 35 | 1¼ | 2⅝ | 14 | 15 |
| | 13 | 21.3 | 0.67 | 0.16 | 32 | 59 | 1.9 | 6.8 |
| P3412 | ¾ | 1.050 | 175 | 40 | 1⅝ | 2½ | 14 | 19 |
| | 19 | 26.7 | 0.78 | 0.18 | 33 | 64 | 1.9 | 8.6 |
| P3413 | 1 | 1.315 | 200 | 50 | 1½ | 2¾ | 14 | 22 |
| | 25 | 33.4 | 0.89 | 0.22 | 38 | 70 | 1.9 | 10.0 |
| P3414 | 1¼ | 1.660 | 300 | 70 | 1⅞ | 3¼ | 12 | 34 |
| | 32 | 42.2 | 1.33 | 0.31 | 43 | 83 | 2.7 | 15.4 |
| P3415 | 1½ | 1.900 | 400 | 80 | 1¾ | 3½ | 11 | 49 |
| | 38 | 48.3 | 1.78 | 0.36 | 45 | 89 | 3.0 | 22.2 |
| P3417 | 2 | 2.375 | 500 | 120 | 2 | 4 | 10 | 55 |
| | 51 | 60.3 | 2.22 | 0.53 | 51 | 102 | 3.4 | 24.9 |

Safety factor of 5

P2609 THRU P2617, P2426 THRU P2431

UNI-CLIP® SUPPORT

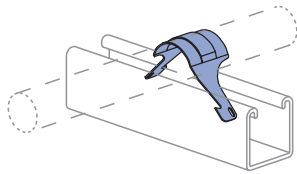

Material: Stainless steel type 301.

The Uni-Clip supports meet or exceed load requirements for American Standard Code for Pressure Piping (1967), and National Electric Code (1971).

Patent No. 2863625.

UNI-CLIP® SUPPORTS FOR THINWALL CONDUIT (E.M.T.)

| Part Number | Conduit Size In (mm) | O.D. Size In (mm) | Wt/100 pcs Lbs (kg) |
|-------------|----------------------|-------------------|---------------------|
| P2426 | ½ | 0.706 | 1.7 |
| | 13 | 17.9 | 0.8 |
| P2427 | ¾ | 0.922 | 2.4 |
| | 19 | 23.4 | 1.1 |
| P2428 | 1 | 1.163 | 3.6 |
| | 25 | 29.5 | 1.6 |
| P2429 | 1¼ | 1.510 | 4.6 |
| | 32 | 38.4 | 2.1 |
| P2430 | 1½ | 1.740 | 5.9 |
| | 38 | 44.2 | 2.7 |
| P2431 | 2 | 2.197 | 8 |
| | 51 | 55.8 | 3.6 |

UNI-CLIP® SUPPORTS FOR RIGID STEEL CONDUIT

| Part Number | Conduit Size In (mm) | O.D. Size In (mm) | Wt/100 pcs Lbs (kg) |
|-------------|----------------------|-------------------|---------------------|
| P2609 | ¾ | 0.675 | 1.6 |
| | 10 | 17.1 | 0.7 |
| P2611 | ½ | 0.840 | 2.3 |
| | 13 | 21.3 | 1.0 |
| P2612 | ¾ | 1.050 | 3.2 |
| | 19 | 26.7 | 1.5 |
| P2613 | 1 | 1.315 | 4.1 |
| | 25 | 33.4 | 1.9 |
| P2614 | 1¼ | 1.660 | 5.1 |
| | 32 | 42.2 | 2.3 |
| P2615 | 1½ | 1.900 | 6.3 |
| | 38 | 48.3 | 2.9 |
| P2617 | 2 | 2.375 | 10 |
| | 51 | 60.3 | 4.5 |

MU025 THRU MU400

MUSTANG UNIVERSAL ONE-PIECE PIPE, CONDUIT (GRC, EMT & IMC) AND TUBING CLAMPS

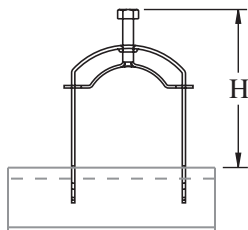
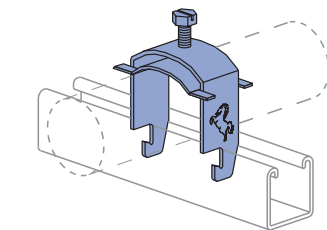

Finish: Electro-galvanized.
 Clamps are 14 ga.

| Part No. | Nominal Trade Size In (mm) | OD | | Height Above Channel "H" | |
|----------|----------------------------|-------------|-------------|--------------------------|--------------|
| | | Min In (mm) | Max In (mm) | Min In (mm) | Max. In (mm) |
| MU025 | ¼ | 0.375 | 0.540 | 1¼ | 2 |
| | 6 | 10 | 14 | 44 | 51 |
| MU037 | ¾ | 0.500 | 0.675 | 1⅞ | 2⅞ |
| | 10 | 13 | 17 | 48 | 54 |
| MU050 | ½ | 0.625 | 0.840 | 2 | 2¼ |
| | 13 | 16 | 21 | 51 | 57 |
| MU075 | ¾ | 0.875 | 1.050 | 2¼ | 2½ |
| | 19 | 22 | 27 | 57 | 64 |
| MU100 | 1 | 1.125 | 1.315 | 2½ | 2¾ |
| | 25 | 29 | 33 | 64 | 70 |
| MU125 | 1¼ | 1.375 | 1.660 | 2¾ | 3⅞ |
| | 32 | 35 | 42 | 70 | 79 |
| MU150 | 1½ | 1.625 | 1.900 | 3 | 3⅝ |
| | 38 | 41 | 48 | 76 | 86 |
| MU200 | 2 | 2.125 | 2.375 | 3½ | 3⅞ |
| | 51 | 54 | 60 | 89 | 98 |
| MU250 | 2½ | 2.625 | 2.875 | 4¼ | 4⅞ |
| | 64 | 67 | 73 | 108 | 117 |
| MU300 | 3 | 3.125 | 3.500 | 4⅞ | 5⅞ |
| | 76 | 79 | 89 | 124 | 137 |
| MU350 | 3½ | 3.625 | 4.000 | 5⅝ | 5⅞ |
| | 89 | 92 | 102 | 137 | 149 |
| MU400 | 4 | 4.125 | 4.500 | 5⅞ | 6⅞ |
| | 102 | 105 | 114 | 149 | 162 |



P2600

UNICUSHION®: ISOLATION MATERIAL

Wt/Carton: 2.5 Lbs (1.1 kg)

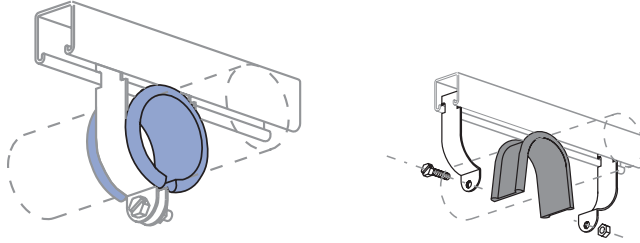

- 25 feet per carton.
- Cut to length as shown in chart below.

UNICUSHION FEATURES

- Shock absorption
- Protection from corrosion and abrasion
- Allowance for expansion and contraction in pipe diameter
- Sound and vibration isolation
- Stability in use from - 50° F (-47° C) to + 350°F (+177° C)
- Flexible elastomer material
- Will not support combustion

UNICUSHION® CLAMP SELECTION GUIDE

EMT CONDUIT

| Nominal Size | Use with Clamp | UNICUSHION Length In (mm) |
|--------------|----------------|---------------------------|
| 3/8" | P1426 | 1 1/4 (45) |
| 1/2" | P1111 | 2 1/8 (54) |
| 3/4" | P1112 | 2 3/4 (70) |
| 1" | P2032 | 3 5/8 (92) |
| 1 1/4" | P2035 | 4 3/4 (121) |
| 1 1/2" | P2037 | 5 1/2 (140) |
| 2" | P1117 | 6 3/4 (172) |

STANDARD PIPE OR RIGID CONDUIT

| Nominal Size | Use with Clamp | UNICUSHION Length In (mm) |
|--------------|----------------|---------------------------|
| 3/8" | P1111 | 2 1/8 (54) |
| 1/2" | P2030 | 3 (76) |
| 3/4" | P2031 | 3 1/4 (83) |
| 1" | P2034 | 4 1/4 (108) |
| 1 1/4" | P2037 | 5 1/4 (133) |
| 1 1/2" | P2038 | 6 (152) |
| 2" | P2042 | 7 1/2 (191) |
| 2 1/2" | P2046 | 9 (229) |
| 3" | P2051 | 11 (279) |
| 3 1/2" | P2055 | 12 1/4 (311) |
| 4" | P2059 | 14 (356) |
| 5" | P2067 | 17 1/2 (445) |
| 6" | P2070-66 | 20 3/4 (527) |

COPPER TUBING TYPE K OR L

| Nominal Size | Use with Clamp | UNICUSHION Length In (mm) |
|--------------|----------------|---------------------------|
| 1/4" | P2026 | 1 1/16 (27) |
| 3/8" | P2027 | 1 1/2 (38) |
| 1/2" | P2028 | 2 1/8 (54) |
| 5/8" | P2029 | 2 1/4 (57) |
| 3/4" | P2030 | 3 (76) |
| 1" | P2032 | 3 5/8 (92) |
| 1 1/4" | P2034 | 4 1/2 (114) |
| 1 1/2" | P1430 | 5 1/4 (133) |
| 2" | P2040 | 6 3/4 (172) |
| 2 1/2" | P2044 | 8 1/4 (210) |
| 3" | P2048 | 10 (254) |
| 3 1/2" | P2052 | 11 1/4 (286) |
| 4" | P2056 | 12 1/2 (318) |
| 5" | P2064 | 16 (406) |
| 6" | P2070-62 | 19 (483) |
| 8" | P2070-82 | 25 (635) |

UNICUSHION® CLAMP CUTTING GUIDE

| O. D. Size In (mm) | Use With Clamp | UNICUSHION Length In (mm) |
|--------------------|----------------|---------------------------|
| 1/4 (6) | P2025 | 7/8 (22) |
| 3/8 (9) | P2026 | 1 1/16 (27) |
| 1/2 (13) | P2027 | 1 1/2 (38) |
| 5/8 (16) | P2028 | 2 1/8 (54) |
| 3/4 (19) | P2029 | 2 1/4 (57) |
| 7/8 (22) | P2030 | 3 (76) |
| 1 (25) | P2031 | 3 1/4 (83) |
| 1 1/8 (29) | P2032 | 3 5/8 (92) |
| 1 1/4 (32) | P2033 | 4 (102) |
| 1 3/8 (35) | P2034 | 4 1/2 (114) |
| 1 1/2 (38) | P2035 | 4 7/8 (124) |
| 1 5/8 (41) | P1430 | 5 1/4 (133) |
| 1 3/4 (45) | P2037 | 5 1/2 (140) |
| 1 7/8 (48) | P2038 | 6 (152) |
| 2 (51) | P2039 | 6 1/2 (165) |
| 2 1/8 (54) | P2040 | 6 3/4 (172) |
| 2 1/4 (57) | P1117 | 7 1/4 (184) |
| 2 3/8 (60) | P2042 | 7 1/2 (191) |
| 2 1/2 (64) | P2043 | 8 (203) |
| 2 5/8 (67) | P2044 | 8 1/4 (210) |
| 2 3/4 (70) | P1118 | 8 3/4 (222) |
| 2 7/8 (73) | P2046 | 9 1/4 (235) |
| 3 (76) | P2047 | 9 1/2 (241) |

| O. D. Size In (mm) | Use With Clamp | UNICUSHION Length In (mm) |
|--------------------|----------------|---------------------------|
| 3 1/8 (79) | P2048 | 10 (254) |
| 3 1/4 (83) | P2049 | 10 1/2 (267) |
| 3 5/8 (86) | P1119 | 10 3/4 (273) |
| 3 1/2 (89) | P2051 | 11 (279) |
| 3 5/8 (92) | P2052 | 11 1/4 (286) |
| 3 3/4 (95) | P2053 | 11 1/2 (292) |
| 3 7/8 (98) | P1120 | 11 3/4 (299) |
| 4 (102) | P2055 | 12 (305) |
| 4 1/8 (105) | P2056 | 12 1/2 (318) |
| 4 1/4 (108) | P2057 | 13 (330) |
| 4 3/8 (111) | P1121 | 13 1/2 (343) |
| 4 1/2 (114) | P2059 | 14 (356) |
| 4 5/8 (118) | P2060 | 14 1/4 (362) |
| 4 3/4 (121) | P2061 | 14 3/4 (375) |
| 4 7/8 (124) | P2062 | 15 (381) |
| 5 (127) | P2063 | 15 1/2 (394) |
| 5 1/8 (130) | P2064 | 16 (406) |
| 5 1/4 (133) | P2065 | 16 1/4 (413) |
| 5 3/8 (137) | P2066 | 16 1/2 (419) |
| 5 1/2 (140) | P2067 | 17 (432) |
| 5 5/8 (143) | P2068 | 17 1/2 (445) |
| 5 3/4 (146) | P2069 | 17 3/4 (451) |
| 5 7/8 (149) | P2070 | 18 1/4 (464) |

| O. D. Size In (mm) | Use With Clamp | UNICUSHION Length In (mm) |
|--------------------|----------------|---------------------------|
| 6 (152) | P2070-61 | 18 1/2 (469) |
| 6 1/8 (156) | P2070-62 | 19 (482) |
| 6 1/4 (159) | P2070-63 | 19 1/4 (489) |
| 6 3/8 (162) | P2070-64 | 19 3/4 (502) |
| 6 1/2 (165) | P1124 | 20 (508) |
| 6 5/8 (168) | P2070-66 | 20 1/2 (521) |
| 6 3/4 (172) | P2070-67 | 21 (533) |
| 6 7/8 (175) | P2070-70 | 21 1/4 (540) |
| 7 (178) | P2070-71 | 21 3/4 (553) |
| 7 1/8 (181) | P2070-72 | 22 (559) |
| 7 1/4 (184) | P2070-73 | 22 1/2 (572) |
| 7 3/8 (187) | P2070-74 | 22 3/4 (578) |
| 7 1/2 (191) | P2070-75 | 23 1/4 (591) |
| 7 5/8 (194) | P2070-76 | 23 1/2 (597) |
| 7 3/4 (197) | P2070-77 | 24 (610) |
| 7 7/8 (200) | P2070-80 | 24 1/2 (622) |
| 8 (203) | P2070-81 | 24 3/4 (629) |
| 8 1/8 (206) | P2070-82 | 25 (635) |
| 8 1/4 (210) | P2070-83 | 25 1/2 (648) |
| 8 3/8 (213) | P2070-84 | 26 (660) |
| 8 1/2 (216) | P1126 | 26 1/4 (667) |

1 5/8" Channel
 Telesruct System
 Nuts & Hardware
 General Fittings
 Pipe/Conduit Supports
 Electrical Fittings
 Concrete Inserts
 1 1/4" Framing System
 1 3/16" Framing System
 Fiberglass System
 Special Metals
 PrimeAngle System
 Product Index

004T008 THRU 098N106, 009N012 THRU 106N114

CUSH-A-CLAMP® ASSEMBLY

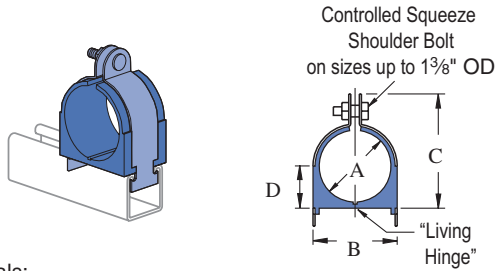

Materials:

- Clamp: Electro-galvanized or stainless steel.
- Cushion: Thermoplastic elastomer. (UV Resistant)

Includes cushion, clamp and hardware.

Temperature Rating:
-50°F to +275°F (-45°C to +135°C)

Insert Width: 1.56" (39.6)

Patent Numbers: 4,516,296; 4,934,635

Part Numbers are "coded" to designate cushion size and clamp size. Examples:

- 004T008** 004 - Cushion Size 1/16" (6.4)
T - With Controlled Squeeze Shoulder Bolt
Available on sizes up to 1 3/8"
- 008 - Clamp Size 3/16" (12.7)
- 009N012** 009 - Cushion Size 3/16" (14.3)
N - With Standard Bolt
- 012 - Clamp Size 1/2" (19.1)

Pipe Series Assembly

| Part No. | Nominal Pipe Size | "A" In(mm) | "B" In(mm) | "C" In(mm) | "D" In(mm) | Wt/100 pcs Lbs/(kg) |
|----------|-------------------|-------------|-------------|-------------|------------|---------------------|
| 009N012 | 1/4 | 0.54 14 | 0.98 25 | 1.34 34 | 0.43 11 | 13 5.9 |
| 011N014 | 3/8 | 0.67 17 | 1.13 29 | 1.54 39 | 0.49 12 | 14 6.4 |
| 014N018 | 1/2 | 0.84 21 | 1.29 33 | 1.82 46 | 0.58 15 | 15 6.8 |
| 017N022 | 3/4 | 1.05 27 | 1.50 38 | 1.95 50 | 0.70 18 | 17 7.7 |
| 021N026 | 1 | 1.31 33 | 1.76 45 | 2.34 59 | 0.81 21 | 19 8.6 |
| 027N032 | 1 1/4 | 1.66 42 | 2.17 55 | 2.73 69 | 0.99 25 | 35 15.9 |
| 030N034 | 1 1/2 | 1.90 48 | 2.35 60 | 2.86 73 | 1.09 28 | 39 17.7 |
| 038N044 | 2 | 2.37 60 | 2.82 72 | 3.67 93 | 1.41 36 | 49 22.2 |
| 046N052 | 2 1/2 | 2.87 73 | 3.32 84 | 4.17 106 | 1.66 42 | 57 25.9 |
| 056N062 | 3 | 3.50 89 | 3.95 100 | 4.79 122 | 1.97 50 | 55 24.9 |
| 064N072 | 3 1/2 | 4.00 102 | 4.45 113 | 5.42 138 | 2.28 58 | 88 39.9 |
| 072N080 | 4 | 4.50 114 | 4.95 126 | 5.92 150 | 2.53 64 | 110 49.9 |
| 089N096 | 5 | 5.56 141 | 6.01 153 | 6.92 176 | 3.06 78 | 130 59.0 |
| 106N114 | 6 | 6.62 168 | 7.07 180 | 8.23 209 | 3.59 91 | 140 63.5 |

Tube Series Assembly

| Part Number | Copper & Steel Tube O. D. Size | Copper Water Pipe (Nominal) | Dimensions | | | | Wt/100 pcs Lbs/(kg) |
|-------------|--------------------------------|-----------------------------|-------------|-------------|-------------|------------|---------------------|
| | | | "A" In(mm) | "B" In(mm) | "C" In(mm) | "D" In(mm) | |
| 004T008 | 1/4 | | 0.25 6 | 0.62 16 | 0.98 29 | 0.27 7 | 10 4.5 |
| 006T010 | 3/8 | 1/4 | 0.37 9 | 0.82 21 | 1.13 29 | 0.33 8 | 11 5.0 |
| 008T012 | 1/2 | 3/8 | 0.50 13 | 0.94 24 | 1.34 34 | 0.40 10 | 13 5.9 |
| 010T014 | 5/8 | 1/2 | 0.62 16 | 1.06 27 | 1.54 39 | 0.46 12 | 14 6.4 |
| 012T016 | 3/4 | 5/8 | 0.75 19 | 1.20 31 | 1.68 43 | 0.52 13 | 14 6.4 |
| 014T018 | 7/8 | 3/4 | 0.87 22 | 1.31 33 | 1.82 46 | 0.58 15 | 15 6.8 |
| 016T020 | 1 | | 1.00 25 | 1.44 37 | 1.95 50 | 0.65 17 | 17 7.7 |
| 018T022 | 1 1/8 | 1 | 1.12 28 | 1.57 40 | 2.08 53 | 0.70 18 | 18 8.2 |
| 020T024 | 1 1/4 | | 1.25 32 | 1.70 43 | 2.21 56 | 0.77 20 | 18 8.2 |
| 022T026 | 1 3/8 | 1 1/4 | 1.37 35 | 1.82 46 | 2.34 59 | 0.83 21 | 20 9.1 |
| 024N028 | 1 1/2 | | 1.50 38 | 1.95 50 | 2.47 63 | 0.90 23 | 33 15.0 |
| 026N030 | 1 5/8 | 1 1/2 | 1.62 41 | 2.07 53 | 2.60 66 | 0.96 24 | 35 15.9 |
| 028N032 | 1 3/4 | | 1.75 45 | 2.20 56 | 2.73 69 | 1.02 26 | 37 16.8 |
| 030N034 | 1 7/8 | | 1.90 48 | 2.35 60 | 2.86 73 | 1.09 28 | 39 17.7 |
| 032N036 | 2 | | 2.00 51 | 2.45 62 | 3.04 77 | 1.15 29 | 46 20.9 |
| 034N040 | 2 1/8 | 2 | 2.12 54 | 2.57 65 | 3.23 82 | 1.27 32 | 47 21.3 |
| 038N044 | 2 3/8 | | 2.37 60 | 2.82 72 | 3.67 93 | 1.41 36 | 49 22.2 |
| 040N046 | 2 1/2 | | 2.50 64 | 2.94 75 | 3.79 96 | 1.46 37 | 51 23.1 |
| 042N048 | 2 5/8 | | 2.62 67 | 3.07 78 | 3.92 100 | 1.53 39 | 55 24.9 |
| 046N052 | 2 7/8 | | 2.87 73 | 3.32 84 | 4.17 106 | 1.66 42 | 57 25.9 |
| 050N054 | 3 | | 3.00 76 | 3.57 91 | 4.42 112 | 1.78 45 | 60 27.2 |
| 050N056 | 3 1/8 | | 3.12 79 | 3.57 91 | 4.42 112 | 1.78 45 | 60 27.2 |
| 053N060 | 3 5/16 | | 3.31 84 | 3.96 101 | 4.75 121 | 1.90 48 | 62 28.1 |
| 056N062 | 3 1/2 | | 3.50 89 | 3.95 100 | 4.79 122 | 1.97 50 | 55 24.9 |
| 058N064 | 3 3/8 | | 3.62 92 | 4.20 107 | 4.99 127 | 2.03 52 | 70 31.8 |
| 064N072 | 4 | | 4.00 102 | 4.45 113 | 5.42 138 | 2.28 58 | 88 39.9 |
| 066N074 | 4 1/8 | | 4.12 105 | 4.57 116 | 5.54 141 | 2.34 59 | 94 42.6 |
| 069N076 | 4 5/16 | | 4.34 110 | 4.96 126 | 5.84 148 | 2.40 61 | 100 45.4 |
| 072N080 | 4 1/2 | | 4.50 114 | 4.95 126 | 5.92 150 | 2.53 64 | 110 49.9 |
| 082N090 | 5 1/8 | | 5.12 130 | 5.57 142 | 6.54 166 | 2.84 72 | 125 56.7 |
| 098N106 | 6 1/8 | | 6.12 155 | 6.57 167 | 7.54 192 | 3.34 85 | 130 59.0 |



004M007 THRU 034M040

CUSH-A-CLAMP® ASSEMBLY OMEGA SERIES™

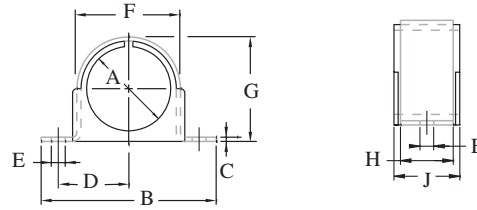
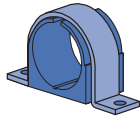

Includes clamp and cushion.
 Materials: Clamp: ZD or stainless steel.
 Cushion: Thermoplastic elastomer.

Note: Cannot be mounted on the slotted side of metal framing channel.
 Can be mounted to any flat surface.

| Part Number | Copper & Steel Tubing O. D. In | Copper Water Pipe (Nominal) In | Pipe Size (Nominal) In | Dimensions | | | | | | | | | Wt/100 pcs Lbs (kg) |
|-------------|--------------------------------|--------------------------------|------------------------|-------------|-------------|-------------|-------------|-------------|-------------|-------------|-------------|-------------|---------------------|
| | | | | "A" In (mm) | "B" In (mm) | "C" In (mm) | "D" In (mm) | "E" In (mm) | "F" In (mm) | "G" In (mm) | "H" In (mm) | "J" In (mm) | |
| 004M007 | ¼ | | | 0.25 | 1.81 | 0.06 | 0.60 | 0.20 | 0.53 | 0.48 | 0.62 | 0.78 | 3.4 |
| | | | | 6 | 46 | 2 | 15 | 5 | 14 | 12 | 16 | 20 | 1.5 |
| 006M008 | ¾ | ¼ | | 0.37 | 1.90 | 0.06 | 0.65 | 0.20 | 0.62 | 0.62 | 0.62 | 0.81 | 4.0 |
| | | | | 9 | 48 | 2 | 17 | 5 | 16 | 16 | 16 | 20 | 1.8 |
| 008M011 | ½ | ¾ | ¼ | 0.50 | 2.20 | 0.06 | 0.80 | 0.26 | 0.82 | 0.75 | 0.75 | 0.98 | 5.5 |
| | | | | 12 | 56 | 2 | 20 | 7 | 21 | 19 | 19 | 25 | 2.5 |
| 010M013 | ⅝ | ½ | ¾ | 0.62 | 2.32 | 0.06 | 0.86 | 0.26 | 0.94 | 0.87 | 0.75 | 0.98 | 6.0 |
| | | | | 16 | 59 | 2 | 22 | 7 | 24 | 22 | 19 | 25 | 2.7 |
| 012M015 | ¾ | ⅝ | | 0.75 | 2.41 | 0.06 | 0.90 | 0.26 | 1.03 | 1.01 | 0.75 | 0.98 | 6.5 |
| | | | | 19 | 61 | 2 | 23 | 7 | 26 | 26 | 19 | 25 | 2.9 |
| 014M017 | ⅞ | ¾ | ½ | 0.87 | 2.56 | 0.06 | 0.98 | 0.26 | 1.18 | 1.03 | 0.75 | 0.98 | 7.1 |
| | | | | 22 | 65 | 2 | 25 | 7 | 30 | 26 | 19 | 25 | 3.2 |
| 016M019 | 1 | | | 1.00 | 2.68 | 0.06 | 1.04 | 0.26 | 1.31 | 1.25 | 0.75 | 0.98 | 7.8 |
| | | | | 25 | 68 | 2 | 26 | 7 | 33 | 32 | 19 | 25 | 3.5 |
| 018M020 | | | ¾ | 1.05 | 2.68 | 0.06 | 1.04 | 0.26 | 1.31 | 1.25 | 0.75 | 0.98 | 8.1 |
| | | | | 27 | 68 | 2 | 26 | 7 | 33 | 32 | 19 | 25 | 3.7 |
| 018M021 | 1½ | 1 | | 1.12 | 2.82 | 0.06 | 1.11 | 0.26 | 1.44 | 1.33 | 0.75 | 0.98 | 8.4 |
| | | | | 28 | 72 | 2 | 28 | 7 | 37 | 34 | 19 | 25 | 3.8 |
| 020M024 | 1¼ | | | 1.25 | 3.00 | 0.08 | 1.20 | 0.26 | 1.65 | 1.47 | 1.25 | 1.56 | 17 |
| | | | | 32 | 76 | 2 | 31 | 7 | 42 | 37 | 32 | 40 | 7.7 |
| 021M026 | | | 1 | 1.31 | 3.12 | 0.08 | 1.26 | 0.26 | 1.76 | 1.71 | 1.25 | 1.56 | 20 |
| | | | | 33 | 79 | 2 | 32 | 7 | 45 | 43 | 32 | 40 | 9.1 |
| 022M026 | 1¾ | 1¼ | | 1.37 | 3.12 | 0.08 | 1.26 | 0.26 | 1.76 | 1.71 | 1.25 | 1.56 | 19 |
| | | | | 35 | 79 | 2 | 32 | 7 | 45 | 43 | 32 | 40 | 8.6 |
| 024M028 | 1½ | | | 1.50 | 3.65 | 0.08 | 1.42 | 0.26 | 1.93 | 1.88 | 1.25 | 1.56 | 20 |
| | | | | 38 | 93 | 2 | 36 | 7 | 49 | 48 | 32 | 40 | 9.1 |
| 026M030 | 1⅝ | 1½ | | 1.62 | 3.77 | 0.08 | 1.48 | 0.26 | 2.07 | 2.00 | 1.25 | 1.56 | 23 |
| | | | | 41 | 96 | 2 | 38 | 7 | 53 | 51 | 32 | 40 | 10.4 |
| 027M032 | | | 1¼ | 1.66 | 3.90 | 0.10 | 1.55 | 0.33 | 2.21 | 2.12 | 1.25 | 1.56 | 32 |
| | | | | 42 | 99 | 3 | 39 | 8 | 56 | 54 | 32 | 40 | 14.5 |
| 028M032 | 1¾ | | | 1.75 | 3.90 | 0.10 | 1.55 | 0.33 | 2.21 | 2.12 | 1.25 | 1.56 | 32 |
| | | | | 45 | 99 | 3 | 39 | 8 | 56 | 54 | 32 | 40 | 14.5 |
| 030M034 | 1⅞ | | 1½ | 1.87 | 4.02 | 0.10 | 1.61 | 0.33 | 2.33 | 2.25 | 1.25 | 1.56 | 34 |
| | | | | 48 | 102 | 3 | 41 | 8 | 59 | 57 | 32 | 40 | 15.4 |
| 032M036 | 2 | | | 2.00 | 4.15 | 0.10 | 1.67 | 0.33 | 2.46 | 2.38 | 1.25 | 1.56 | 36 |
| | | | | 51 | 105 | 3 | 42 | 8 | 63 | 61 | 32 | 40 | 16.3 |
| 034M040 | 2½ | | | 2.12 | 4.40 | 0.10 | 1.80 | 0.33 | 2.71 | 2.62 | 1.25 | 1.56 | 41 |
| | | | | 54 | 112 | 3 | 46 | 8 | 69 | 67 | 32 | 40 | 18.6 |
| 038M044 | | | 2 | 2.37 | 4.71 | 0.10 | 1.94 | 0.33 | 2.96 | 2.88 | 1.25 | 1.56 | 44 |
| | | | | 60 | 120 | 3 | 49 | 8 | 75 | 73 | 32 | 40 | 20.0 |
| 082M090 | 5⅝ | | | 5.12 | 7.64 | 0.10 | 3.41 | 0.40 | 5.83 | 6.75 | 1.25 | 1.56 | 120 |
| | | | | 130 | 194 | 3 | 87 | 10 | 148 | 172 | 32 | 40 | 54.4 |

1½" Channel
 Telestrut System
 Nuts & Hardware
 General Fittings
 Pipe/Conduit Supports
 Electrical Fittings
 Concrete Inserts
 1½" Framing System
 1¼" Framing System
 1⅜" Framing System
 Fiberglass System
 Special Metals
 PrimeAngle System
 Product Index

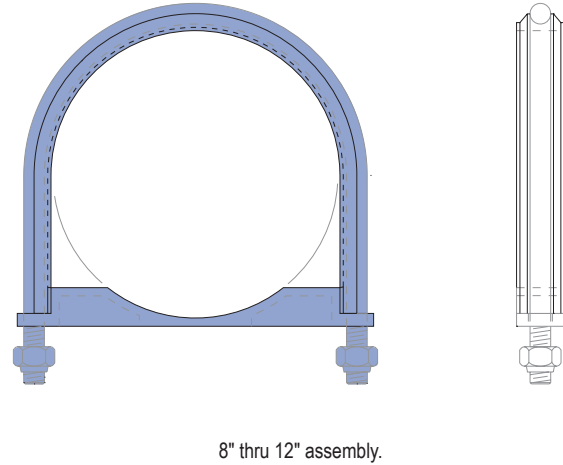
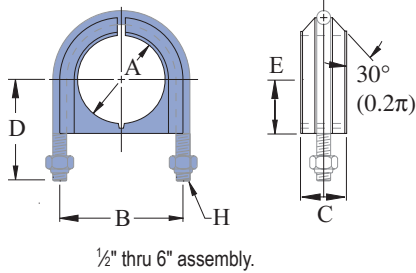

Includes U bolt, cushion, and hardware.

Materials:

U Bolt: Electro-galvanized finish or Type 316SS

Cushion: Thermoplastic elastomer.

Note: Not intended for use with metal framing components due to the length of the thread.

| Part Number | Pipe Size (Nominal) In (mm) | Dimensions | | | | | | | H | Wt/100 pcs Lbs (kg) |
|------------------------------------|--------------------------------|----------------|----------------|----------------|----------------|----------------|----------------|---------------|-------|------------------------|
| | | "A" In (mm) | "B" In (mm) | "C" In (mm) | "D" In (mm) | "E" In (mm) | "F" In (mm) | | | |
| UB ¹ / ₂ PA | 1/2 | 0.84 | 1.60 | 0.68 | 1.5 | 0.67 | 1/4 | 1/4-20 UNC-2B | 9 | |
| | 13 | 21 | 41 | 17 | 38 | 17 | 6.4 | | 4.1 | |
| UB ³ / ₄ PA | 3/4 | 1.05 | 1.80 | 0.68 | 1.6 | 0.78 | 1/4 | 1/4-20 UNC-2B | 10 | |
| | 19 | 27 | 46 | 17 | 41 | 20 | 6.4 | | 4.5 | |
| UB1PA | 1 | 1.31 | 2.05 | 0.68 | 1.7 | 0.91 | 1/4 | 1/4-20 UNC-2B | 12 | |
| | 25 | 33 | 52 | 17 | 43 | 23 | 6.4 | | 5.4 | |
| UB1 ¹ / ₄ PA | 1 1/4 | 1.66 | 2.54 | 1.24 | 2.1 | 1.08 | 3/8 | 3/8-16 UNC-2B | 36 | |
| | 32 | 42 | 65 | 32 | 53 | 27 | 9.5 | | 16.3 | |
| UB1 ¹ / ₂ PA | 1 1/2 | 1.90 | 2.78 | 1.24 | 2.2 | 1.19 | 3/8 | 3/8-16 UNC-2B | 32 | |
| | 38 | 48 | 71 | 32 | 56 | 30 | 9.5 | | 14.5 | |
| UB2PA | 2 | 2.37 | 3.32 | 1.24 | 2.5 | 1.45 | 3/8 | 3/8-16 UNC-2B | 42 | |
| | 51 | 60 | 84 | 32 | 64 | 37 | 9.5 | | 19.1 | |
| UB2 ¹ / ₂ PA | 2 1/2 | 2.87 | 3.88 | 1.24 | 3.0 | 1.69 | 1/2 | 1/2-13 UNC-2B | 72 | |
| | 64 | 73 | 99 | 32 | 76 | 43 | 12.7 | | 32.7 | |
| UB3PA | 3 | 3.50 | 4.50 | 1.24 | 3.3 | 2.00 | 1/2 | 1/2-13 UNC-2B | 84 | |
| | 76 | 89 | 114 | 32 | 84 | 51 | 12.7 | | 38.1 | |
| UB3 ¹ / ₂ PA | 3 1/2 | 4.00 | 5.00 | 1.24 | 3.7 | 2.25 | 1/2 | 1/2-13 UNC-2B | 93 | |
| | 89 | 102 | 127 | 32 | 94 | 57 | 12.7 | | 42.2 | |
| UB4PA | 4 | 4.50 | 5.50 | 1.24 | 3.9 | 2.5 | 1/2 | 1/2-13 UNC-2B | 102 | |
| | 102 | 114 | 140 | 32 | 99 | 64 | 12.7 | | 46.3 | |
| UB5PA | 5 | 5.56 | 6.59 | 1.24 | 4.5 | 3.03 | 1/2 | 1/2-13 UNC-2B | 123 | |
| | 127 | 141 | 167 | 32 | 114 | 77 | 12.7 | | 55.8 | |
| UB6PA | 6 | 6.62 | 7.81 | 1.44 | 5.4 | 3.56 | 5/8 | 5/8-11 UNC-2B | 123 | |
| | 152 | 168 | 198 | 37 | 137 | 90 | 15.9 | | 55.8 | |
| UB8PA | 8 | 8.62 | 9.84 | 1.44 | 6.4 | 4.56 | 5/8 | 5/8-11 UNC-2B | 243 | |
| | 203 | 219 | 250 | 37 | 163 | 116 | 15.9 | | 110.2 | |
| UB10PA | 10 | 10.75 | 12.25 | 1.65 | 7.7 | 5.68 | 3/4 | 3/4-10 UNC-2B | 492 | |
| | 254 | 273 | 311 | 42 | 196 | 144 | 19.1 | | 223.2 | |
| UB12PA | 12 | 12.75 | 14.25 | 1.65 | 8.7 | 6.68 | 3/4 | 3/4-10 UNC-2B | 563 | |
| | 305 | 324 | 362 | 42 | 221 | 170 | 19.1 | | 255.4 | |



CG-10 THRU CG-40

CUSH-A-GRIP®

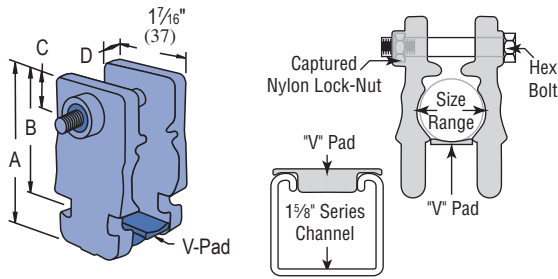

| Part Number | O.D. Tube Sizes In(mm) | | Nominal Pipe Sizes In(mm) | | Diameters In(mm) | PullOut Load Lbs(kN) | Slip Load Lbs(kN) |
|-------------|------------------------|-------|---------------------------|-----|------------------|----------------------|-------------------|
| CG-10 | 1/4 | 3/8 | 1/2 | 3/4 | 0.25 - 0.54 | 500 | 40 |
| | 6 | 10 | 13 | 6 | 6 - 14 | 2.22 | 0.18 |
| CG-20 | 5/8 | 3/4 | 7/8 | 3/8 | 0.62 - 0.87 | 500 | 40 |
| | 16 | 19 | 22 | 10 | 16 - 22 | 2.22 | 0.18 |
| CG-30 | 7/8 | 1 | 1 1/8 | 3/4 | 0.87 - 1.12 | 500 | 40 |
| | 22 | 25 | 29 | 19 | 22 - 29 | 2.22 | 0.18 |
| CG-40 | 1 | 1 1/8 | 1 1/4 | 3/4 | 1.00 - 1.31 | 500 | 40 |
| | 25 | 29 | 32 | 19 | 25 - 33 | 2.22 | 0.18 |

Includes Cushion, V-pad, and Hardware.

Materials: Cushion: Thermoplastic elastomer.

Hardware: Stainless Steel with Captured Nylon Locknut

Temperature Rating:

-40°F to +275°F (-40°C to 135°C)

| Part Number | Nominal Pipe Size | "A" In(mm) | "B" In(mm) | "C" In(mm) | "D" In(mm) | Hex Head Cap Screw & Lock Nut | Wt/100 pcs Lbs(kg) |
|-------------|-------------------|------------|------------|------------|------------|-------------------------------|--------------------|
| CG-10 | 1/4 | 1 5/16 | 1 3/8 | 3/8 | 3/16 | 1/4-20 x 1 1/2" | 4 |
| | | 49 | 35 | 10 | 5 | | 1.8 |
| CG-20 | 3/8 | 2 3/8 | 1 5/8 | 7/16 | 1/4 | 1/4-20 x 2" | 6 |
| | | 60 | 42 | 11 | 6 | | 2.7 |
| CG-30 | 1/2 | 2 7/16 | 1 13/16 | 7/16 | 5/16 | 1/4-20 x 2" | 8 |
| | | 65 | 46 | 11 | 8 | | 3.6 |
| CG-40 | 3/4 | 2 11/16 | 1 15/16 | 7/16 | 5/16 | 1/4-20 x 2" | 8 |
| | | 68 | 49 | 11 | 8 | | 3.6 |

PUX3834 THRU PUX41810

CUSH-A-THERM™

The only airtight, crush-resistant insulation clamp on the market.

- Maintains thermal barrier protection
- Prevents condensation
- Properly supports pipe and tube
- Absorbs vibration

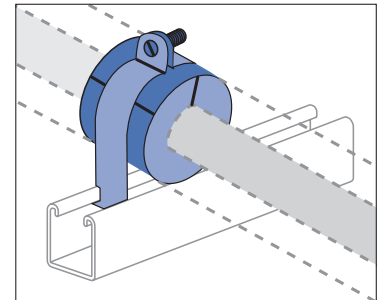
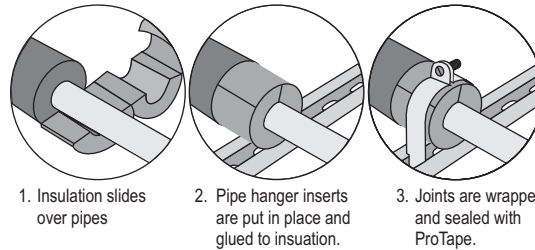

Nominal 3/4" Wall

| Part Number | Hole Size In(mm) | Copper Nom. I.D. In(mm) | O.D. In(mm) | IPS In(mm) | O.D. In(mm) | Length In(mm) |
|-------------|------------------|-------------------------|-------------|------------|-------------|---------------|
| PUX3834 | 3/8 ID | 1/4 | 3/8 | - | 1.81 | 2.17 |
| | 10 | 6 | 10 | - | 46 | 55 |
| PUX1234 | 1/2 ID | 3/8 | 1/2 | 1/4 | 1.89 | 2.17 |
| | 13 | 10 | 13 | 6 | 48 | 55 |
| PUX5834 | 5/8 ID | 1/2 | 5/8 | 3/8 | 2.05 | 2.17 |
| | 16 | 13 | 16 | 10 | 52 | 55 |
| PUX3434 | 3/4 ID | 5/8 | 3/4 | - | 2.22 | 2.17 |
| | 19 | 16 | 19 | - | 56 | 55 |
| PUX7834 | 7/8 ID | 3/4 | 7/8 | 1/2 | 2.44 | 2.17 |
| | 22 | 19 | 22 | 13 | 62 | 55 |
| PUX11834 | 1 1/8 ID | 1 | 1 1/8 | 3/4 | 2.76 | 2.17 |
| | 29 | 25 | 29 | 29 | 70 | 55 |
| PUX13834 | 1 3/8 ID | 1 1/4 | 1 3/8 | 1 | 3.19 | 2.56 |
| | 35 | 32 | 35 | 25 | 81 | 65 |
| PUX15834 | 1 5/8 ID | 1 1/2 | 1 5/8 | 1 1/4 | 3.35 | 2.58 |
| | 41 | 38 | 41 | 32 | 85 | 66 |
| PUX21834 | 2 1/8 ID | 2 | 2 1/8 | - | 3.86 | 2.56 |
| | 54 | 51 | 54 | - | 98 | 65 |
| PUX23834 | 2 3/8 ID | 2 1/4 | 2 3/8 | 2 | 4.29 | 2.96 |
| | 60 | 57 | 60 | 51 | 109 | 75 |
| PUX25834 | 2 5/8 ID | 2 1/2 | 2 5/8 | - | 4.87 | 2.96 |
| | 67 | 64 | 67 | - | 124 | 75 |
| PUX31834 | 3 1/8 ID | 3 | 3 1/8 | - | 5.00 | 3.35 |
| | 79 | 76 | 79 | - | 127 | 85 |
| PUX35834 | 3 3/8 ID | 3 1/2 | 3 3/8 | - | 5.94 | 3.94 |
| | 92 | 89 | 92 | - | 151 | 100 |
| PUX41834 | 4 1/8 ID | 4 | 4 1/8 | 3 1/2 | 6.14 | 3.94 |
| | 105 | 102 | 105 | 89 | 156 | 100 |

Nominal 1" Wall

| Part Number | Hole Size In(mm) | Copper Nom. I.D. In(mm) | O.D. In(mm) | IPS In(mm) | O.D. In(mm) | Length In(mm) |
|-------------|------------------|-------------------------|-------------|------------|-------------|---------------|
| PUX5810 | 3/8 ID | 1/2 | 5/8 | 3/8 | 2.54 | 2.17 |
| | 16 | 13 | 16 | 10 | 65 | 55 |
| PUX3410 | 3/4 ID | 5/8 | 3/4 | - | 2.82 | 2.17 |
| | 19 | 16 | 19 | - | 72 | 55 |
| PUX7810 | 7/8 ID | 3/4 | 7/8 | 1/2 | 2.82 | 2.17 |
| | 22 | 19 | 22 | 13 | 72 | 55 |
| PUX11810 | 1 1/8 ID | 1 | 1 1/8 | 3/4 | 3.06 | 2.17 |
| | 29 | 25 | 29 | 19 | 78 | 55 |
| PUX13810 | 1 3/8 ID | 1 1/4 | 1 3/8 | 1 | 3.33 | 2.56 |
| | 35 | 32 | 35 | 25 | 85 | 65 |
| PUX15810 | 1 5/8 ID | 1 1/2 | 1 5/8 | 1 1/4 | 3.65 | 2.56 |
| | 41 | 38 | 41 | 32 | 93 | 65 |
| PUX21810 | 2 1/8 ID | 2 | 2 1/8 | - | 4.16 | 2.56 |
| | 54 | 51 | 54 | - | 106 | 65 |
| PUX23810 | 2 3/8 ID | 2 1/4 | 2 3/8 | 2 | 3.92 | 2.56 |
| | 60 | 57 | 60 | 51 | 100 | 65 |
| PUX25810 | 2 5/8 ID | 2 1/2 | 2 5/8 | - | 4.87 | 2.96 |
| | 67 | 64 | 67 | - | 124 | 75 |
| PUX31810 | 3 1/8 ID | 3 | 3 1/8 | - | 5.14 | 3.35 |
| | 79 | 76 | 79 | - | 131 | 85 |
| PUX35810 | 3 3/8 ID | 3 1/2 | 3 3/8 | - | 6.48 | 3.94 |
| | 92 | 89 | 92 | - | 165 | 100 |
| PUX41810 | 4 1/8 ID | 4 | 4 1/8 | 3 1/2 | 6.48 | 3.94 |
| | 105 | 102 | 105 | 89 | 165 | 100 |

J1205 THRU J1280, J1205 N THRU J 1280 N (PLASTIC COATED)

"J" CONDUIT & PIPE HANGER

NOTE: Maximum operating temperature is 300°F (148.8°C)

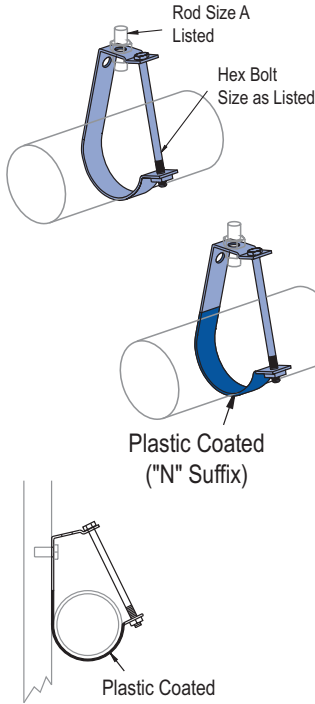

"T" Bolt and Nut Included

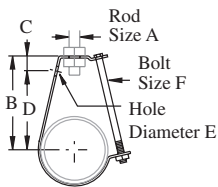

Hanger Rod Suspended

| Part No. | Wt/100 pcs Lbs (kg) | Part No. | Wt/100 pcs Lbs (kg) | Pipe Size In | "A" In (mm) | "B" In (mm) | "C" In (mm) | "D" In (mm) | "E" In (mm) | "F" In (mm) | Load Lbs (kN) |
|----------|---------------------|----------|---------------------|--------------|-------------|-------------|-------------|-------------|-------------|-------------|---------------|
| J1205 | 20 9.1 | J1205N | 21 9.5 | 1/2 | 3/8 | 2 5/8 | 1 | 2 | 1 3/32 | 1/4 x 2 1/4 | 400 1.78 |
| J1207 | 21 9.5 | J1207N | 22 10.0 | 3/4 | 3/8 | 2 7/8 | 1 | 2 1/4 | 1 3/32 | 1/4 x 2 1/4 | 400 1.78 |
| J1210 | 24 10.9 | J1210N* | 25 11.3 | 1 | 3/8 | 3 | 1 | 2 3/8 | 1 3/32 | 1/4 x 2 1/2 | 400 1.78 |
| J1212 | 27 12.2 | J1212N | 29 13.2 | 1 1/4 | 3/8 | 3 1/4 | 1 | 2 1/2 | 1 3/32 | 1/4 x 2 3/4 | 400 1.78 |
| J1215 | 29 13.2 | J1215N* | 31 14.1 | 1 1/2 | 3/8 | 3 1/2 | 1 | 2 5/8 | 1 3/32 | 1/4 x 3 | 400 1.78 |
| J1220 | 33 15.0 | J1220N* | 35 15.9 | 2 | 3/8 | 3 3/4 | 1 1/8 | 2 5/8 | 1 3/32 | 1/4 x 3 1/2 | 400 1.78 |
| J1225 | 71 32.2 | J1225N | 74 33.6 | 2 1/2 | 1/2 | 4 3/8 | 1 1/8 | 3 5/8 | 9/16 | 3/8 x 4 1/2 | 800 3.56 |
| J1230 | 78 35.4 | J1230N* | 81 36.7 | 3 | 1/2 | 4 7/8 | 1 1/8 | 4 | 9/16 | 3/8 x 5 | 800 3.56 |
| J1235 | 85 38.6 | J1235N | 88 39.9 | 3 1/2 | 1/2 | 5 1/8 | 1 1/8 | 4 1/4 | 9/16 | 3/8 x 6 | 800 3.56 |
| J1240 | 178 80.7 | J1240N* | 182 82.6 | 4 | 5/8 | 6 1/8 | 1 1/8 | 5 1/8 | 9/16 | 3/8 x 6 | 800 3.56 |
| J1250 | 199 90.3 | J1250N | 203 92.1 | 5 | 5/8 | 6 3/4 | 1 1/8 | 5 3/4 | 9/16 | 3/8 x 7 1/2 | 800 3.56 |
| J1260 | 231 104.8 | J1260N* | 236 107.0 | 6 | 3/4 | 7 3/4 | 1 1/4 | 6 1/2 | 9/16 | 3/8 x 8 1/2 | 1,000 4.45 |
| J1280 | 449 203.7 | J1280N | 458 207.7 | 8 | 7/8 | 9 1/4 | 1 1/4 | 8 | 9/16 | 3/8 x 10 | 1,200 5.34 |

*Standard glass drainline and glass process pipe sizes. Minimum safety factor of five (5) on ultimate load.

P2474

PIPE ROLLER FOR 1/2" - 4" PIPE

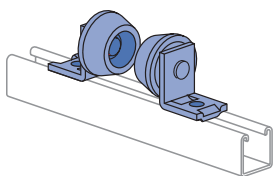

Sold in pairs.

Requires 2 each 1/2" x 1/8" bolts and 1/2" channel nuts per assembly. Sold separately.

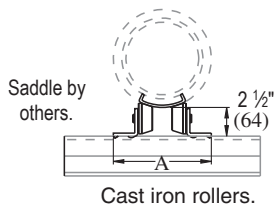

Design Load
500 Lbs (2.22kN)

Wt/100 pcs: 268 Lbs (121.6 kg)

Chart for Dimension A

| Pipe Size In | No Insulation In (mm) | Insulation Thickness | | | | | |
|--------------|-----------------------|----------------------|----------------|------------|----------------|------------|------------|
| | | 1" In (mm) | 1 1/2" In (mm) | 2" In (mm) | 2 1/2" In (mm) | 3" In (mm) | 4" In (mm) |
| 1/2 | 6 1/2 | 6 1/2 | - | - | - | - | - |
| | 165 | 165 | - | - | - | - | - |
| 3/4 | 6 1/2 | 6 1/2 | 6 5/8 | 6 7/8 | - | - | - |
| | 165 | 165 | 168 | 175 | - | - | - |
| 1 | 6 1/2 | 6 1/2 | 6 5/8 | 6 7/8 | - | - | - |
| | 165 | 165 | 168 | 175 | - | - | - |
| 1 1/4 | 6 1/2 | 6 1/2 | 6 7/8 | 7 1/8 | 7 3/8 | - | - |
| | 165 | 165 | 175 | 181 | 187 | - | - |
| 1 1/2 | 6 1/2 | 6 1/2 | 6 7/8 | 7 1/8 | 7 3/8 | - | - |
| | 165 | 165 | 175 | 181 | 187 | - | - |
| 2 | 6 1/2 | 6 5/8 | 7 1/8 | 7 3/8 | 7 1/2 | 8 | - |
| | 165 | 168 | 181 | 187 | 191 | 203 | - |
| 2 1/2 | 6 1/2 | 6 5/8 | 7 1/8 | 7 3/8 | 7 1/2 | 8 | - |
| | 165 | 168 | 181 | 187 | 191 | 203 | - |
| 3 | 6 1/2 | 7 | 7 1/2 | 7 3/4 | 7 7/8 | 8 1/8 | - |
| | 165 | 178 | 191 | 197 | 200 | 206 | - |
| 3 1/2 | 6 1/2 | 7 | 7 1/2 | 7 3/4 | 7 7/8 | 8 1/8 | - |
| | 165 | 178 | 191 | 197 | 200 | 206 | - |
| 4 | 6 5/8 | 7 1/4 | 7 5/8 | 7 7/8 | 8 | 8 3/8 | 9 |
| | 168 | 184 | 194 | 200 | 203 | 213 | 229 |



P2474-1 THRU P2474-4

PIPE ROLLER FOR 1" - 8" PIPE

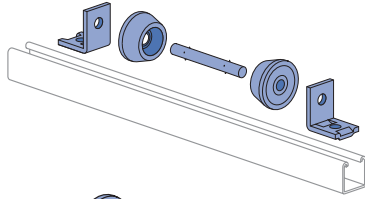

Parts are shipped loose and are easily assembled during installation.

Design Load
750 Lbs (3.34 kN)

| Part Number | A In (mm) | Wt/100 pcs Lbs (kg) |
|-------------|--------------------------------|------------------------|
| P2474-1 | 6 ³ / ₄ | 299 |
| | 172 | 135.6 |
| P2474-2 | 7 ¹ / ₂ | 304 |
| | 191 | 137.9 |
| P2474-3 | 8 ¹ / ₂ | 311 |
| | 216 | 141.1 |
| P2474-4 | 9 ⁹ / ₁₆ | 319 |
| | 243 | 144.7 |

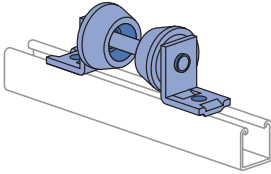
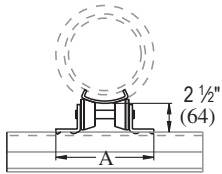

Chart for Roller Part Number Selection

| Pipe Size In | No Insulation | Insulation Thickness | | | | | |
|-------------------------------|------------------|----------------------|--|-----------|--|-----------|------------|
| | | 1" (25.4) | 1 ¹ / ₂ " (38.1) | 2" (50.8) | 2 ¹ / ₂ " (63.5) | 3" (76.2) | 4" (101.6) |
| 1/2 | P2474-1 | P2474-1 | P2474-1 | P2474-2 | - | - | - |
| 3/4 | P2474-1 | P2474-1 | P2474-1 | P2474-2 | - | - | - |
| 1 | P2474-1 | P2474-1 | P2474-1 | P2474-2 | - | - | - |
| 1 ¹ / ₄ | P2474-1 | P2474-1 | P2474-1 | P2474-2 | - | - | - |
| 1 ¹ / ₂ | P2474-1 | P2474-1 | P2474-2 | P2474-2 | P2474-2 | - | - |
| 2 | P2474-1 | P2474-1 | P2474-2 | P2474-2 | P2474-2 | - | - |
| 2 ¹ / ₂ | P2474-1 | P2474-1 | P2474-2 | P2474-2 | P2474-2 | - | - |
| 3 | P2474-1 | P2474-2 | P2474-2 | P2474-3 | P2474-3 | P2474-3 | - |
| 3 ¹ / ₂ | P2474-1 | P2474-2 | P2474-2 | P2474-3 | P2474-3 | P2474-3 | - |
| 4 | P2474-1 | P2474-2 | P2474-2 | P2474-3 | P2474-3 | P2474-3 | - |
| 5 | P2474-2 | P2474-3 | P2474-3 | P2474-3 | P2474-3 | P2474-4 | P2474-4 |
| 6 | P2474-2 | P2474-3 | P2474-3 | P2474-3 | P2474-3 | P2474-4 | P2474-4 |
| 8 | P2474-2 | P2474-3 | P2474-4 | P2474-4 | P2474-4 | P2474-4 | P2474-4 |



Saddle by others.

- Pipe roller will fit standard saddles.
- Select proper roller from chart.
- Requires 2 each 1/2" x 15/16" bolts and 1/2" channel nuts per assembly. Sold separately.

P2475

PIPE ROLLER FOR 6" - 16" PIPE

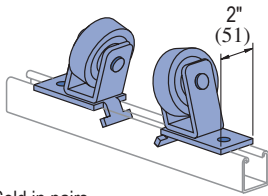

Material: Cast iron rollers.

- Requires 2 each 1/2" x 15/16" bolts and 1/2" channel nuts per assembly. Sold separately.

Chart for Dimension A

| Pipe Size In | No Insulation In (mm) | Insulation Thickness | | | | | |
|-----------------|--------------------------------|--------------------------------|--|--------------------------------|--|--------------------------------|--------------------------------|
| | | 1" (25.4) | 1 ¹ / ₂ " (38.1) | 2" (50.8) | 2 ¹ / ₂ " (63.5) | 3" (76.2) | 4" (101.6) |
| 6 | 9 ¹ / ₂ | 10 ¹ / ₄ | 10 ¹ / ₂ | 10 ³ / ₄ | 11 | 11 ³ / ₈ | 11 ⁷ / ₈ |
| | 241 | 260.4 | 279 | 273 | 279 | 289 | 302 |
| 8 | 10 ³ / ₈ | * | 11 | 11 ³ / ₈ | 11 ³ / ₄ | 12 | 12 ¹ / ₂ |
| | 257 | | 279 | 289 | 299 | 305 | 318 |
| 10 | 10 ³ / ₄ | * | 11 ⁵ / ₈ | 12 | 12 ¹ / ₄ | 12 ¹ / ₂ | 13 |
| | 273 | | 295 | 305 | 311 | 316 | 330 |
| 12 | 11 ¹ / ₄ | * | 12 ¹ / ₈ | 12 ¹ / ₂ | 12 ³ / ₄ | 13 | 13 ¹ / ₂ |
| | 286 | | 308 | 318 | 324 | 330 | 343 |
| 14 | 11 ⁵ / ₈ | * | 12 ¹ / ₂ | 12 ³ / ₈ | 13 | 13 ³ / ₈ | 14 |
| | 295 | | 318 | 327 | 330 | 340 | 356 |
| 16 | 12 ¹ / ₂ | * | 13 | 13 ³ / ₈ | 13 ³ / ₄ | 14 | 14 ¹ / ₂ |
| | 308 | | 330 | 340 | 352 | 356 | 368 |

(*Not used for this size)

Sold in pairs.

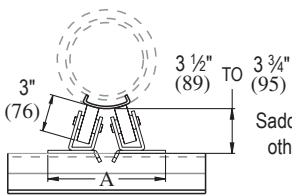

Saddle by others.

Design Load
1500 Lbs (6.67 kN)

Wt/100 pcs: 680 Lbs (308.4 kg)

P2476

PIPE ROLLER FOR 16" - 24" PIPE

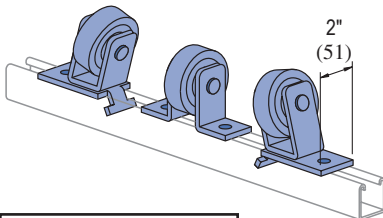

- Requires 4 each 1/2" x 15/16" bolts and 1/2" channel nuts per assembly. Sold separately.

Chart for Dimension A

| Pipe Size In | Insulation Thickness | | | | |
|-----------------|--|--------------------------------|--|--------------------------------|--------------------------------|
| | 1 ¹ / ₂ " (38.1) | 2" (50.8) | 2 ¹ / ₂ " (63.5) | 3" (76.2) | 4" (101.6) |
| 16 | - | - | 13 ³ / ₈ | 14 | 14 ¹ / ₂ |
| | - | - | 352 | 356 | 368 |
| 18 | 13 ³ / ₈ | 14 | 14 ¹ / ₂ | 14 ¹ / ₂ | 15 |
| | 346 | 356 | 359 | 368 | 381 |
| 20 | 14 ¹ / ₈ | 14 ¹ / ₂ | 14 ³ / ₄ | 15 | 15 ¹ / ₂ |
| | 359 | 368 | 375 | 381 | 394 |
| 24 | 15 ¹ / ₄ | 15 ¹ / ₂ | 15 ⁵ / ₈ | 16 ¹ / ₈ | 16 ¹ / ₂ |
| | 387 | 394 | 403 | 410 | 422 |

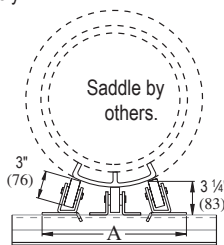

Saddle by others.

Design Load
2000 Lbs (8.90 kN)

Material: Cast iron rollers.

Wt/100 pcs: 1046 Lbs (474.5 kg)

Standard Dimensions for 1 1/2" (41 mm) width series channel fittings (Unless Otherwise Shown on Drawing)

Hole Diameter: 9/16" (14mm); Hole Spacing - From End: 1 3/16" (21 mm); Hole Spacing - On Center: 1 7/8" (48 mm); Width: 1 5/8" (41mm); Thickness: 1/4" (6mm)

P2481 PIPE SUPPORT BRACKET

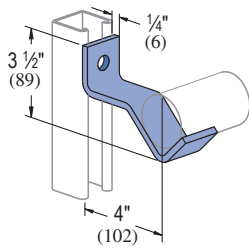

For 1/2" pipe to 1 1/2" pipe.

P2482 PIPE SUPPORT BRACKET

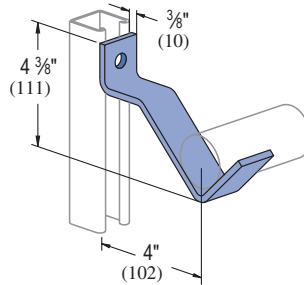

For 2" pipe to 3" pipe.

P2243 PIPE BLOCK

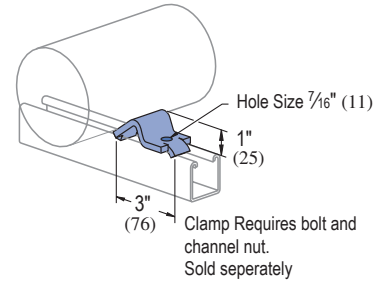

For 2" (51) to 8" (203) Pipes

| Wt/100 pcs Lbs (kg) | Design Load (Upright Channel) | | |
|------------------------|-------------------------------|-------------------|-------------------|
| | P1000 Lbs (kN) | P1100 Lbs (kN) | P2000 Lbs (kN) |
| 90 | 85 | 85 | 85 |
| 40.8 | 0.38 | 0.38 | 0.38 |

| Wt/100 pcs Lbs (kg) | Design Load (Upright Channel) | | |
|------------------------|-------------------------------|-------------------|-------------------|
| | P1000 Lbs (kN) | P1100 Lbs (kN) | P2000 Lbs (kN) |
| 139 | 185 | 120 | 95 |
| 63.0 | 0.82 | 0.53 | 0.42 |

Wt/100 pcs: 40 Lbs (18.1 kg)

UP-BK THRU **UP-MPDS**

UNIPIER™

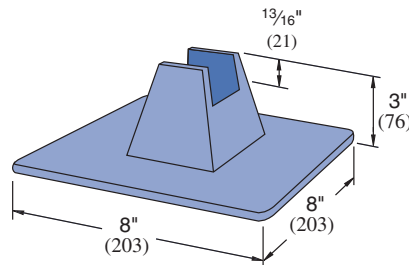

| Part Number | UniPier Bases Qty. | Description |
|--------------|--------------------|---|
| UP-BK | 4 | UniPier Base Only (4 Bases & Hardware) |
| UP-SPSS-6 HG | 4 | UP-BK + 4 Pcs P4100T HG @ 6" (152mm) Long for up to 3 1/2" (89mm) Pipe |
| UP-SPSS-10HG | 4 | UP-BK + 4 Pcs P4100T HG @ 10" (254mm) Long for 4" to 8" (101.6 to 203mm) Pipe |
| UP-MPDS-26HG | 4 | UP-BK + 2 Pcs P1000T HG @ 26" (66.0cm) Long for Trapeze |
| UP-MPDS-38HG | 4 | UP-BK + 2 Pcs P1000T HG @ 38" (96.5cm) Long for Trapeze |
| UP-MPDS-50HG | 4 | UP-BK + 2 Pcs P1000T HG @ 50" (127.0cm) Long for Trapeze |
| UP-MPDS-62HG | 4 | UP-BK + 2 Pcs P1000T HG @ 62" (157.5cm) Long for Trapeze |

The UniPier Rooftop support system provides a simple and versatile way to support and manage pipe, tubing, conduit, HVAC systems, and the like. The UniPier system supports without roof surface penetration and allows the parts to remain off the surface

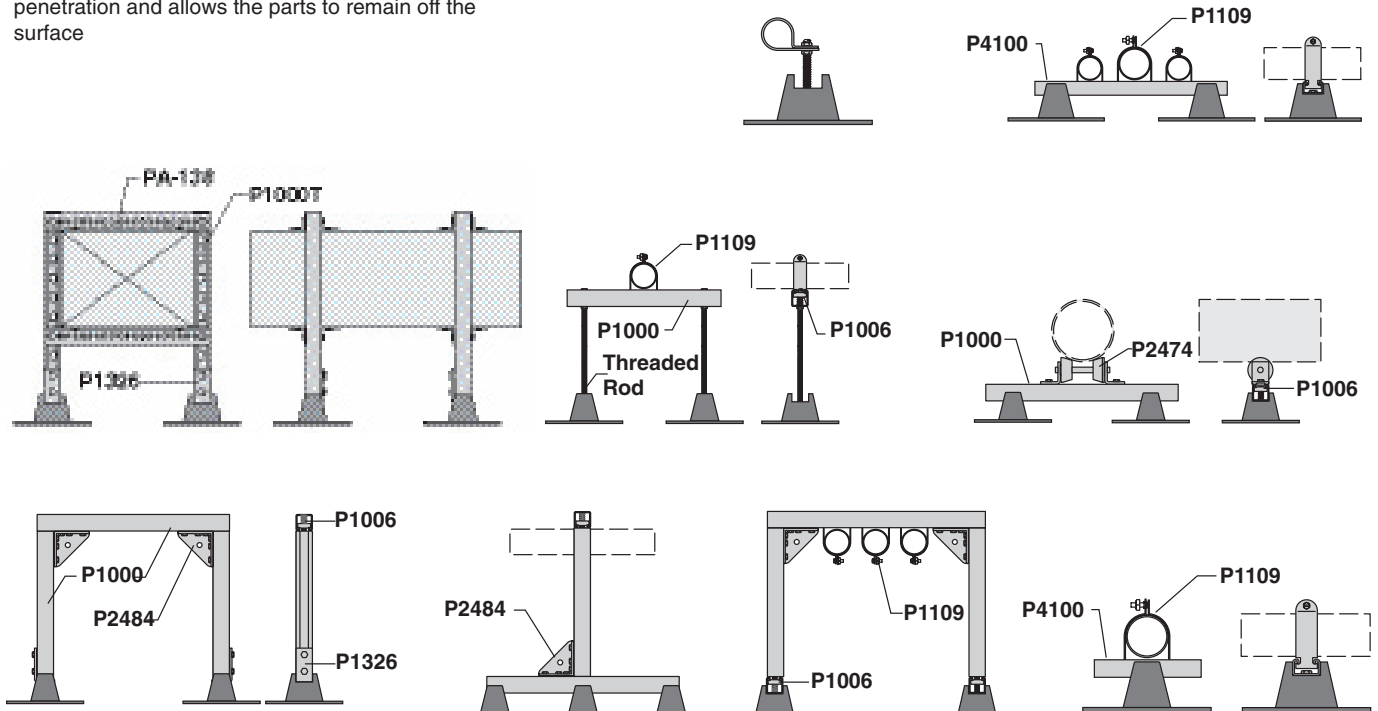



| Nominal Pipe Dia. | Centerline to Centerline (In/mm) | | | | | | | | | | | | | | | | | |
|-------------------|----------------------------------|---------------|---------------|---------------|---------------|---------------|---------------|---------------|---------------|---------------|---------------|---------------|---------------|---------------|---------------|---------------|---------------|---------------|
| | 3/4" (19mm) | | 1" (25mm) | | | 1 1/4" (32mm) | | | 1 1/2" (38mm) | | | 2" (51mm) | | | 2 1/2" (64mm) | | | |
| | T | S | T | F | S | T | F | S | T | F | S | T | F | S | T | F | S | |
| 3/4" 19mm | T | 4 3/4 121 | - | - | - | - | - | - | - | - | - | - | - | - | - | - | - | - |
| | S | 4 1/2 114 | 4 3/4 108 | - | - | - | - | - | - | - | - | - | - | - | - | - | - | - |
| 1" 25mm | T | 5 127 | 4 3/4 121 | 5 1/4 133 | - | - | - | - | - | - | - | - | - | - | - | - | - | - |
| | F | 6 152 | 5 3/4 146 | 6 1/4 159 | 7 1/4 184 | - | - | - | - | - | - | - | - | - | - | - | - | - |
| | S | 4 3/4 121 | 4 1/2 114 | 5 127 | 6 152 | 4 1/2 114 | - | - | - | - | - | - | - | - | - | - | - | - |
| 1 1/4" 32mm | T | 5 1/4 133 | 5 127 | 5 1/2 140 | 6 1/2 165 | 5 127 | 5 1/2 140 | - | - | - | - | - | - | - | - | - | - | - |
| | F | 6 1/4 159 | 6 152 | 6 1/2 165 | 7 1/2 191 | 6 1/4 159 | 6 3/4 171 | 7 1/4 197 | - | - | - | - | - | - | - | - | - | - |
| | S | 4 3/4 121 | 4 1/2 114 | 5 127 | 6 152 | 4 1/2 114 | 5 1/4 133 | 6 1/4 159 | 4 3/4 121 | - | - | - | - | - | - | - | - | - |
| 1 1/2" 38mm | T | 5 3/4 133 | 5 127 | 5 1/2 140 | 6 1/2 165 | 5 1/4 133 | 5 3/4 146 | 6 1/4 171 | 5 1/4 133 | 5 3/4 146 | - | - | - | - | - | - | - | - |
| | F | 6 1/2 165 | 6 1/4 159 | 6 3/4 171 | 7 3/4 197 | 6 1/4 159 | 6 3/4 171 | 8 203 | 6 1/2 165 | 7 178 | 8 203 | - | - | - | - | - | - | - |
| | S | 5 127 | 4 3/4 121 | 5 1/4 133 | 6 1/4 159 | 4 3/4 121 | 5 1/4 133 | 6 152 | 5 127 | 5 1/2 140 | 6 1/2 165 | 5 127 | - | - | - | - | - | - |
| 2" 51mm | T | 5 3/4 146 | 5 1/2 140 | 6 152 | 7 178 | 5 1/2 140 | 6 152 | 7 1/4 184 | 5 3/4 146 | 6 1/4 159 | 7 1/4 184 | 5 3/4 146 | 6 1/2 165 | - | - | - | - | - |
| | F | 7 178 | 6 3/4 171 | 7 1/4 184 | 8 1/4 210 | 6 3/4 171 | 7 1/4 184 | 8 1/2 216 | 7 178 | 7 1/2 191 | 8 1/2 216 | 7 178 | 7 3/4 197 | 9 229 | - | - | - | - |
| | S | 5 1/4 133 | 5 127 | 5 1/2 140 | 6 1/2 165 | 5 127 | 5 1/2 140 | 6 1/4 171 | 5 1/4 133 | 5 3/4 146 | 6 1/4 171 | 5 1/4 133 | 6 152 | 7 1/4 184 | 5 1/2 140 | - | - | - |
| 2 1/2" 64mm | T | 6 152 | 5 3/4 146 | 6 1/4 159 | 7 1/4 184 | 6 152 | 6 1/2 165 | 7 1/2 191 | 6 152 | 6 1/2 165 | 7 1/2 191 | 6 152 | 6 1/2 165 | 7 178 | 8 1/4 210 | 6 1/2 165 | 7 1/4 184 | - |
| | F | 7 1/2 191 | 7 1/4 184 | 7 3/4 197 | 8 3/4 222 | 7 1/4 184 | 7 3/4 197 | 9 229 | 7 1/2 191 | 8 203 | 9 229 | 7 1/2 191 | 8 1/4 210 | 9 1/2 241 | 7 3/4 197 | 8 3/4 222 | 10 254 | - |
| | S | 5 1/2 140 | 5 1/4 133 | 5 3/4 146 | 6 1/4 171 | 5 1/4 133 | 5 3/4 146 | 7 178 | 5 1/2 140 | 6 152 | 7 178 | 5 1/2 140 | 6 1/4 159 | 7 1/2 191 | 5 3/4 146 | 6 3/4 171 | 8 203 | 6 152 |
| 3" 76mm | T | 6 1/4 159 | 6 152 | 6 1/2 165 | 7 1/2 191 | 6 1/4 159 | 6 3/4 171 | 7 3/4 197 | 6 1/4 159 | 6 3/4 171 | 8 203 | 6 1/2 165 | 7 1/4 184 | 8 1/2 216 | 6 3/4 171 | 7 1/2 191 | 9 229 | 7 178 |
| | F | 7 3/4 197 | 7 1/2 191 | 8 203 | 9 229 | 7 1/2 191 | 8 203 | 9 1/4 235 | 7 3/4 197 | 8 1/4 210 | 9 1/4 235 | 7 3/4 197 | 8 1/2 216 | 9 3/4 248 | 8 203 | 9 229 | 10 1/4 260 | 8 3/4 210 |
| | S | 5 3/4 146 | 5 1/2 140 | 6 152 | 7 178 | 5 1/2 140 | 6 152 | 7 1/4 184 | 5 3/4 146 | 6 1/4 159 | 7 1/4 184 | 5 3/4 146 | 6 1/2 165 | 7 3/4 197 | 6 152 | 7 178 | 8 1/4 210 | 6 1/4 159 |
| 4" 102mm | T | 7 1/2 191 | 7 1/4 184 | 7 3/4 197 | 8 3/4 222 | 7 1/4 184 | 7 3/4 197 | 9 229 | 7 1/2 191 | 8 203 | 9 229 | 7 1/2 191 | 8 1/4 210 | 9 1/2 241 | 7 3/4 197 | 8 3/4 222 | 10 254 | 8 203 |
| | F | 9 229 | 8 3/4 222 | 9 1/4 235 | 10 1/4 260 | 8 3/4 222 | 9 1/4 235 | 10 1/2 267 | 9 229 | 9 1/2 241 | 10 1/2 267 | 9 229 | 9 3/4 248 | 11 279 | 9 1/4 235 | 10 1/4 260 | 11 1/2 292 | 9 1/2 241 |
| | S | 6 3/4 171 | 6 1/2 165 | 7 178 | 8 203 | 6 1/2 165 | 7 178 | 8 1/4 210 | 6 3/4 171 | 7 1/4 184 | 8 1/4 210 | 6 3/4 171 | 7 1/2 191 | 8 3/4 210 | 7 178 | 8 203 | 9 1/4 235 | 7 1/4 184 |
| 5" 127mm | T | 8 203 | 7 3/4 197 | 8 1/4 210 | 9 1/4 235 | 7 3/4 197 | 8 1/4 210 | 9 1/2 241 | 8 203 | 8 1/2 216 | 9 1/2 241 | 8 203 | 8 3/4 222 | 10 254 | 8 1/4 210 | 9 1/4 235 | 10 1/2 267 | 8 1/2 216 |
| | F | 9 1/2 241 | 9 1/4 235 | 9 3/4 248 | 10 3/4 273 | 9 1/4 235 | 9 3/4 248 | 11 279 | 9 1/2 241 | 10 254 | 11 279 | 9 1/2 241 | 10 1/4 260 | 11 1/2 292 | 9 3/4 248 | 10 3/4 273 | 12 305 | 10 254 |
| | S | 7 1/4 184 | 7 178 | 7 1/2 191 | 8 1/4 210 | 7 178 | 7 1/2 191 | 8 3/4 222 | 7 1/4 184 | 7 3/4 197 | 8 3/4 222 | 7 1/4 184 | 8 203 | 9 1/4 235 | 7 1/2 191 | 8 1/4 210 | 9 1/4 235 | 7 3/4 197 |
| 6" 152mm | T | 8 3/4 222 | 8 1/2 216 | 9 229 | 10 254 | 8 1/2 216 | 9 229 | 10 1/4 260 | 8 3/4 222 | 9 1/4 235 | 10 3/4 273 | 8 3/4 222 | 9 1/2 241 | 10 3/4 273 | 9 229 | 10 254 | 11 1/4 286 | 9 1/4 235 |
| | F | 10 254 | 9 3/4 248 | 10 1/4 260 | 11 1/4 286 | 9 3/4 248 | 10 1/4 260 | 11 1/2 292 | 10 254 | 10 1/2 267 | 11 1/2 292 | 10 254 | 10 3/4 273 | 12 305 | 10 1/4 260 | 11 1/4 286 | 12 1/2 318 | 10 1/2 267 |
| | S | 7 3/4 197 | 7 1/2 191 | 8 203 | 9 229 | 7 1/2 191 | 8 203 | 9 1/4 235 | 7 3/4 197 | 8 1/4 210 | 9 1/4 235 | 7 3/4 197 | 8 1/2 216 | 9 3/4 248 | 8 203 | 9 229 | 10 1/4 260 | 8 1/4 210 |
| 8" 203mm | T | 8 3/4 222 | 8 1/2 216 | 9 229 | 10 254 | 8 1/2 216 | 9 229 | 10 1/4 260 | 8 3/4 222 | 9 1/4 235 | 10 3/4 273 | 8 3/4 222 | 9 1/2 241 | 10 3/4 273 | 9 229 | 10 254 | 11 1/4 286 | 9 1/4 235 |
| | F | 11 1/4 286 | 11 279 | 11 1/2 292 | 12 1/2 318 | 11 279 | 11 1/2 292 | 12 3/4 324 | 11 1/4 286 | 11 3/4 324 | 12 3/4 324 | 11 1/4 286 | 12 305 | 13 1/4 337 | 11 1/2 292 | 12 1/2 318 | 13 3/4 349 | 11 3/4 298 |
| 10" 254mm | T | 11 1/4 286 | 11 279 | 11 1/2 292 | 12 1/2 318 | 11 279 | 11 1/2 292 | 12 3/4 324 | 11 1/4 286 | 11 3/4 324 | 12 3/4 324 | 11 1/4 286 | 12 305 | 13 1/4 337 | 11 1/2 292 | 12 1/2 318 | 13 3/4 349 | 11 3/4 298 |
| | F | 12 1/2 318 | 12 1/4 311 | 12 3/4 324 | 13 3/4 349 | 12 1/4 311 | 12 3/4 324 | 14 356 | 12 1/2 318 | 13 330 | 14 356 | 12 1/2 318 | 13 1/4 337 | 14 1/2 368 | 12 3/4 324 | 13 3/4 349 | 15 381 | 13 330 |
| 12" 305mm | T | 12 1/4 311 | 12 305 | 12 1/2 318 | 13 1/2 343 | 12 305 | 12 1/2 318 | 13 3/4 349 | 12 1/4 311 | 12 3/4 324 | 13 3/4 349 | 12 1/4 311 | 13 330 | 14 1/4 362 | 12 1/2 318 | 13 1/2 343 | 14 3/4 375 | 12 3/4 324 |
| | F | 14 356 | 13 3/4 349 | 14 1/4 362 | 15 1/4 387 | 13 3/4 349 | 14 1/4 362 | 15 1/2 394 | 14 356 | 14 1/2 368 | 15 1/2 394 | 14 356 | 14 1/2 368 | 16 406 | 14 1/4 362 | 15 1/4 387 | 16 1/2 419 | 14 1/2 368 |

Product Index
 PrimeAngle System
 Special Metals
 Fiberglass System
 1 3/16" Framing System
 1 1/4" Framing System
 Concrete Inserts
 Electrical Fittings
 Pipe/Conduit Supports
 General Fittings
 Nuts & Hardware
 Telestrut System
 Channel
 1 5/8"

PIPE SPACING TABLE

This chart, developed by Julius Getlan of Seelye Stevenson Value & Knect, consulting engineers, New York City, enables one to quickly determine the centerline-to-centerline dimension between any two size pipes on a rack.

Select the smaller pipe size at top and select the other at the side of the table. Where the appropriate columns intersect, the dimension is given.

These factors are included in the dimensions given:

- O.D. of flanges and fittings.
- 1" insulation over flanges and fittings.
- All fractional dimensions less than 1/4" were increased to the next larger 1/4".
- Clear space between fittings as follows:
 1. 1" between piping 3" and smaller.
 2. 1 1/2" between a pipe 3" and smaller and a pipe 4" or larger.
 3. 2" between piping 4" and larger.

T – denotes threaded IPS pipe. F – denotes flanged fittings on pipe. S – denotes soldered or brazed tubing.

| Centerline to Centerline (In/mm) | | | | | | | | | | | | | | | | | | | | |
|----------------------------------|--------|--------|------------|--------|--------|------------|--------|--------|------------|--------|--------|------------|--------|-------------|--------|-------------|-----|-------------------|---|--------------|
| 3" (76mm) | | | 4" (102mm) | | | 5" (127mm) | | | 6" (152mm) | | | 8" (203mm) | | 10" (254mm) | | 12" (305mm) | | Nominal Pipe Dia. | | |
| T | F | S | T | F | S | T | F | S | T | F | S | T | F | T | F | T | F | | | |
| 7 3/4 | - | - | - | - | - | - | - | - | - | - | - | - | - | - | - | - | - | - | T | 3" 76mm |
| 197 | - | - | - | - | - | - | - | - | - | - | - | - | - | - | - | - | - | - | F | |
| 9 1/4 | 10 1/2 | - | - | - | - | - | - | - | - | - | - | - | - | - | - | - | - | - | S | |
| 235 | 267 | - | - | - | - | - | - | - | - | - | - | - | - | - | - | - | - | - | T | 4" 102mm |
| 7 1/4 | 8 1/2 | 6 1/2 | - | - | - | - | - | - | - | - | - | - | - | - | - | - | - | - | F | |
| 184 | 216 | 165 | - | - | - | - | - | - | - | - | - | - | - | - | - | - | - | - | S | |
| 9 | 10 1/4 | 8 1/4 | 10 | - | - | - | - | - | - | - | - | - | - | - | - | - | - | - | T | 5" 127mm |
| 229 | 260 | 210 | 254 | - | - | - | - | - | - | - | - | - | - | - | - | - | - | - | F | |
| 10 1/2 | 11 3/4 | 9 3/4 | 11 1/2 | 13 | - | - | - | - | - | - | - | - | - | - | - | - | - | - | S | |
| 267 | 298 | 248 | 292 | 330 | - | - | - | - | - | - | - | - | - | - | - | - | - | - | T | 6" 152mm |
| 8 1/4 | 9 1/2 | 7 1/2 | 9 1/4 | 10 3/4 | 8 1/2 | - | - | - | - | - | - | - | - | - | - | - | - | - | F | |
| 210 | 241 | 191 | 235 | 273 | 216 | - | - | - | - | - | - | - | - | - | - | - | - | - | S | |
| 9 1/2 | 10 3/4 | 8 3/4 | 10 1/4 | 12 | 9 3/4 | 11 | - | - | - | - | - | - | - | - | - | - | - | - | T | 8" 203mm |
| 241 | 273 | 222 | 260 | 305 | 248 | 279 | - | - | - | - | - | - | - | - | - | - | - | - | F | |
| 11 | 12 1/4 | 10 1/4 | 12 | 13 1/2 | 11 1/4 | 12 1/2 | 14 | - | - | - | - | - | - | - | - | - | - | - | S | |
| 279 | 311 | 260 | 305 | 343 | 286 | 318 | 356 | - | - | - | - | - | - | - | - | - | - | - | T | 10" 254mm |
| 8 3/4 | 10 | 8 | 9 3/4 | 11 1/4 | 9 | 10 1/4 | 11 3/4 | 9 1/2 | - | - | - | - | - | - | - | - | - | - | F | |
| 222 | 254 | 203 | 248 | 286 | 229 | 260 | 298 | 241 | - | - | - | - | - | - | - | - | - | - | S | |
| 10 1/4 | 11 1/2 | 9 1/2 | 11 1/4 | 12 3/4 | 10 1/2 | 11 3/4 | 13 1/4 | 11 | 12 1/2 | - | - | - | - | - | - | - | - | - | T | 12" 305mm |
| 260 | 292 | 241 | 286 | 324 | 267 | 298 | 337 | 279 | 318 | - | - | - | - | - | - | - | - | - | F | |
| 11 1/2 | 12 1/4 | 10 1/4 | 12 1/2 | 14 | 11 3/4 | 13 | 14 1/2 | 12 1/4 | 13 1/4 | 15 | - | - | - | - | - | - | - | - | S | |
| 292 | 311 | 273 | 318 | 356 | 298 | 330 | 368 | 311 | 337 | 381 | - | - | - | - | - | - | - | - | T | 10" 254mm |
| 9 1/4 | 10 1/2 | 8 1/2 | 10 1/4 | 11 3/4 | 9 1/2 | 10 3/4 | 12 1/4 | 10 | 11 1/2 | 12 3/4 | 10 1/2 | - | - | - | - | - | - | - | F | |
| 235 | 267 | 216 | 260 | 298 | 241 | 273 | 311 | 254 | 292 | 324 | 267 | - | - | - | - | - | - | - | S | |
| 11 1/4 | 12 3/4 | 10 3/4 | 12 1/2 | 14 | 11 3/4 | 13 | 14 1/2 | 12 1/4 | 13 3/4 | 15 | 12 3/4 | 14 3/4 | - | - | - | - | - | - | T | 12" 305mm |
| 286 | 324 | 273 | 318 | 356 | 298 | 330 | 368 | 311 | 349 | 381 | 324 | 375 | - | - | - | - | - | - | F | |
| 12 3/4 | 14 | 12 | 13 3/4 | 15 1/4 | 13 | 14 1/4 | 15 3/4 | 13 1/2 | 15 | 16 1/4 | 14 | 16 1/4 | 17.5 | - | - | - | - | - | T | |
| 324 | 356 | 305 | 349 | 387 | 330 | 362 | 400 | 343 | 381 | 413 | 356 | 413 | 17.5 | - | - | - | - | - | F | |
| 12 3/4 | 14 | 12 | 13 3/4 | 15 1/4 | 13 | 14 1/4 | 15 3/4 | 13 1/2 | 15 | 16 1/4 | 14 | 16 1/4 | 17 1/2 | 17 1/2 | - | - | - | - | T | |
| 324 | 356 | 305 | 349 | 387 | 330 | 362 | 400 | 343 | 381 | 413 | 356 | 413 | 445 | 445 | - | - | - | - | F | |
| 14 | 15 1/4 | 13 1/4 | 15 | 16 1/2 | 14 1/4 | 15 1/2 | 17 | 14 3/4 | 16 1/4 | 17 1/2 | 15 1/4 | 17 1/2 | 18 3/4 | 18 3/4 | 20 | - | - | - | T | |
| 356 | 387 | 337 | 381 | 419 | 362 | 394 | 432 | 375 | 413 | 445 | 387 | 445 | 476 | 476 | 508 | - | - | - | F | |
| 13 3/4 | 15 | 13 | 14 3/4 | 16 1/4 | 14 | 15 1/4 | 16 3/4 | 14 1/2 | 16 | 17 1/4 | 15 | 17 1/4 | 18 1/2 | 18 1/2 | 19 3/4 | 19 1/2 | - | - | T | |
| 349 | 381 | 330 | 375 | 413 | 356 | 387 | 425 | 368 | 406 | 438 | 381 | 438 | 470 | 470 | 502 | 495 | - | - | F | |
| 15 1/2 | 16 3/4 | 14 3/4 | 16 1/2 | 18 | 15 3/4 | 17 | 18 1/4 | 16 1/4 | 17 3/4 | 19 | 16 3/4 | 14 | 20 1/4 | 20 1/4 | 21 1/2 | 21 1/4 | 29 | - | T | |
| 394 | 425 | 375 | 419 | 457 | 400 | 432 | 464 | 413 | 451 | 483 | 425 | 356 | 514 | 514 | 546 | 540 | 737 | - | F | |



CHANNEL SELECTION FOR SCHEDULE 10 SPRINKLER PIPE TRAPEZE HANGERS

Note: Based on NFPA-13-1996 Section Modulus Table 3-10.1.7(a). Each of the following tables indicate the allowable span of the trapeze and the nominal pipe size for the specified channel. An entry of "-" indicates that the channel cannot be used for this span/pipe size combination. The table is based on a maximum allowable bending stress of 15 KSI and a midspan concentrated load from 15 ft of water-filled pipe, plus 250 lb.

| Unistrut Channel | Section Modulus in ³ (cm ³) |
|------------------|--|
| P3000 | 0.154 2.52 |
| P1000 | 0.202 3.31 |
| P5500 | 0.391 6.41 |
| P5000 | 0.628 10.29 |

| Unistrut Channel | Section Modulus in ³ (cm ³) |
|------------------|--|
| P3001 | 0.431 7.06 |
| P1001 | 0.572 9.37 |
| P5501 | 1.153 18.89 |
| P5001 | 1.916 31.40 |

| Nominal Pipe Dia. (in) | Schedule 10 Pipe | | I. D. (in) | Pipe Weight (p/f) | Water Weight (p/f) | Total Weight (p/f) |
|------------------------|------------------|---------------------|------------|-------------------|--------------------|--------------------|
| | O.D. (in) | Wall Thickness (in) | | | | |
| 1 | 1.315 | 0.109 | 1.097 | 1.41 | 0.42 | 1.83 |
| 1¼ | 1.660 | 0.109 | 1.442 | 1.81 | 0.73 | 2.54 |
| 1½ | 1.900 | 0.109 | 1.682 | 2.09 | 0.99 | 3.08 |
| 2 | 2.375 | 0.109 | 2.157 | 2.64 | 1.63 | 4.28 |
| 2½ | 2.875 | 0.120 | 2.635 | 3.53 | 2.44 | 5.97 |
| 3 | 3.500 | 0.120 | 3.260 | 4.34 | 3.73 | 8.07 |
| 3½ | 4.000 | 0.120 | 3.760 | 4.98 | 4.97 | 9.95 |
| 4 | 4.500 | 0.120 | 4.260 | 5.62 | 6.38 | 12.00 |
| 5 | 5.563 | 0.134 | 5.295 | 7.78 | 9.85 | 17.63 |
| 6 | 6.625 | 0.134 | 6.357 | 9.30 | 14.20 | 23.50 |
| 8 | 8.625 | 0.188 | 8.249 | 16.96 | 23.91 | 40.87 |
| 10 | 10.750 | 0.188 | 10.374 | 21.23 | 37.82 | 59.04 |

| Trapeze Span | NFPA 13 Required Trapeze Section Modulus for Sch 10 Pipe | | | | | | | | | | | |
|--------------|--|------|------|------|------|------|------|------|------|------|------|------|
| | Pipe Diameter | | | | | | | | | | | |
| | 1" | 1¼" | 1½" | 2" | 2½" | 3" | 3½" | 4" | 5" | 6" | 8" | 10" |
| 1' - 6" | 0.08 | 0.09 | 0.09 | 0.09 | 0.10 | 0.11 | 0.12 | 0.13 | 0.15 | 0.18 | 0.24 | 0.32 |
| 2' - 0" | 0.11 | 0.12 | 0.12 | 0.13 | 0.13 | 0.15 | 0.16 | 0.17 | 0.20 | 0.24 | 0.32 | 0.43 |
| 2' - 6" | 0.14 | 0.14 | 0.15 | 0.16 | 0.17 | 0.18 | 0.20 | 0.21 | 0.25 | 0.30 | 0.40 | 0.54 |
| 3' - 0" | 0.17 | 0.17 | 0.18 | 0.19 | 0.20 | 0.22 | 0.24 | 0.26 | 0.31 | 0.36 | 0.48 | 0.65 |
| 4' - 0" | 0.22 | 0.23 | 0.24 | 0.25 | 0.27 | 0.29 | 0.32 | 0.34 | 0.41 | 0.48 | 0.64 | 0.87 |
| 5' - 0" | 0.28 | 0.29 | 0.30 | 0.31 | 0.34 | 0.37 | 0.40 | 0.43 | 0.51 | 0.59 | 0.80 | 1.08 |
| 6' - 0" | 0.33 | 0.35 | 0.36 | 0.38 | 0.41 | 0.44 | 0.48 | 0.51 | 0.61 | 0.71 | 0.97 | 1.30 |
| 7' - 0" | 0.39 | 0.40 | 0.41 | 0.44 | 0.47 | 0.52 | 0.55 | 0.60 | 0.71 | 0.83 | 1.13 | 1.52 |
| 8' - 0" | 0.44 | 0.46 | 0.47 | 0.50 | 0.54 | 0.59 | 0.63 | 0.68 | 0.81 | 0.95 | 1.29 | 1.73 |
| 9' - 0" | 0.50 | 0.52 | 0.53 | 0.56 | 0.61 | 0.66 | 0.71 | 0.77 | 0.92 | 1.07 | 1.45 | 1.95 |
| 10' - 0" | 0.56 | 0.58 | 0.59 | 0.63 | 0.68 | 0.74 | 0.79 | 0.85 | 1.02 | 1.19 | 1.61 | 2.17 |

Values taken from NFPA 13 (1996 Edition), Table 2-6.1.5(a)

| Trapeze Span | Single Channel Trapeze for Sch 10 Pipe | | | | | | | | | | | |
|--------------|--|-------|-------|-------|-------|-------|-------|-------|-------|-------|-------|-------|
| | Pipe Diameter | | | | | | | | | | | |
| | 1" | 1¼" | 1½" | 2" | 2½" | 3" | 3½" | 4" | 5" | 6" | 8" | 10" |
| 1' - 6" | P3000 | P3000 | P3000 | P3000 | P3000 | P3000 | P3000 | P3000 | P3000 | P1000 | P5500 | P5500 |
| 2' - 0" | P3000 | P3000 | P3000 | P3000 | P3000 | P3000 | P1000 | P1000 | P1000 | P5500 | P5500 | P5000 |
| 2' - 6" | P3000 | P3000 | P3000 | P1000 | P1000 | P1000 | P1000 | P5500 | P5500 | P5500 | P5000 | P5000 |
| 3' - 0" | P1000 | P1000 | P1000 | P1000 | P1000 | P5500 | P5500 | P5500 | P5500 | P5500 | P5000 | N/A |
| 4' - 0" | P5500 | P5500 | P5500 | P5500 | P5500 | P5500 | P5500 | P5500 | P5000 | P5000 | N/A | N/A |
| 5' - 0" | P5500 | P5500 | P5500 | P5500 | P5500 | P5500 | P5000 | P5000 | P5000 | P5000 | N/A | N/A |
| 6' - 0" | P5500 | P5500 | P5500 | P5500 | P5000 | P5000 | P5000 | P5000 | P5000 | N/A | N/A | N/A |
| 7' - 0" | P5500 | P5000 | P5000 | P5000 | P5000 | P5000 | P5000 | P5000 | N/A | N/A | N/A | N/A |
| 8' - 0" | P5000 | P5000 | P5000 | P5000 | P5000 | P5000 | N/A | N/A | N/A | N/A | N/A | N/A |
| 9' - 0" | P5000 | P5000 | P5000 | P5000 | P5000 | N/A | N/A | N/A | N/A | N/A | N/A | N/A |
| 10' - 0" | P5000 | P5000 | P5000 | N/A | N/A | N/A | N/A | N/A | N/A | N/A | N/A | N/A |

| Trapeze Span | Double Channel Trapeze for Sch 10 Pipe | | | | | | | | | | | |
|--------------|--|-------|-------|-------|-------|-------|-------|-------|-------|-------|-------|-------|
| | Pipe Diameter | | | | | | | | | | | |
| | 1" | 1¼" | 1½" | 2" | 2½" | 3" | 3½" | 4" | 5" | 6" | 8" | 10" |
| 1' - 6" | P3001 | P3001 | P3001 | P3001 | P3001 | P3001 | P3001 | P3001 | P3001 | P3001 | P3001 | P3001 |
| 2' - 0" | P3001 | P3001 | P3001 | P3001 | P3001 | P3001 | P3001 | P3001 | P3001 | P3001 | P3001 | P3001 |
| 2' - 6" | P3001 | P3001 | P3001 | P3001 | P3001 | P3001 | P3001 | P3001 | P3001 | P3001 | P3001 | P1001 |
| 3' - 0" | P3001 | P3001 | P3001 | P3001 | P3001 | P3001 | P3001 | P3001 | P3001 | P3001 | P1001 | P5501 |
| 4' - 0" | P3001 | P3001 | P3001 | P3001 | P3001 | P3001 | P3001 | P3001 | P3001 | P1001 | P5501 | P5501 |
| 5' - 0" | P3001 | P3001 | P3001 | P3001 | P3001 | P3001 | P3001 | P3001 | P1001 | P5501 | P5501 | P5501 |
| 6' - 0" | P3001 | P3001 | P3001 | P3001 | P3001 | P1001 | P1001 | P1001 | P5501 | P5501 | P5501 | P5001 |
| 7' - 0" | P3001 | P3001 | P3001 | P1001 | P1001 | P1001 | P1001 | P5501 | P5501 | P5501 | P5501 | P5001 |
| 8' - 0" | P1001 | P1001 | P1001 | P1001 | P1001 | P5501 | P5501 | P5501 | P5501 | P5501 | P5001 | N/A |
| 9' - 0" | P1001 | P1001 | P1001 | P1001 | P5501 | P5501 | P5501 | P5501 | P5501 | P5501 | P5001 | N/A |
| 10' - 0" | P1001 | P5501 | P5501 | P5501 | P5501 | P5501 | P5501 | P5501 | P5501 | P5001 | P5001 | N/A |

CHANNEL SELECTION FOR SCHEDULE 40 SPRINKLER PIPE TRAPEZE HANGERS

Note: Based on NFPA-13-1996 Section Modulus Table 3-10.1.7(a). Each of the following tables indicate the allowable span of the trapeze and the nominal pipe size for the specified channel. An entry of "-" indicates that the channel cannot be used for this span/pipe size combination. The table is based on a maximum allowable bending stress of 15 KSI and a midspan concentrated load from 15 ft of water-filled pipe, plus 250 lb.

| Unistrut Channel | Section Modulus in ³ (cm ³) |
|------------------|--|
| P3000 | 0.154 2.52 |
| P1000 | 0.202 3.31 |
| P5500 | 0.391 6.41 |
| P5000 | 0.628 10.29 |

| Unistrut Channel | Section Modulus in ³ (cm ³) |
|------------------|--|
| P3001 | 0.431 7.06 |
| P1001 | 0.572 9.37 |
| P5501 | 1.153 18.89 |
| P5001 | 1.916 31.40 |

| Nominal Pipe Dia. (in) | Schedule 40 Pipe | | | Pipe Weight (p/f) | Water Weight (p/f) | Total Weight (p/f) |
|------------------------|------------------|---------------------|------------|-------------------|--------------------|--------------------|
| | O.D. (in) | Wall Thickness (in) | I. D. (in) | | | |
| 1 | 1.315 | 0.133 | 1.049 | 1.68 | 0.39 | 2.07 |
| 1¼ | 1.660 | 0.140 | 1.380 | 2.27 | 0.67 | 2.94 |
| 1½ | 1.900 | 0.145 | 1.610 | 2.72 | 0.91 | 3.63 |
| 2 | 2.375 | 0.154 | 2.067 | 3.66 | 1.50 | 5.16 |
| 2½ | 2.875 | 0.203 | 2.469 | 5.80 | 2.14 | 7.94 |
| 3 | 3.500 | 0.216 | 3.068 | 7.58 | 3.31 | 10.89 |
| 3½ | 4.000 | 0.226 | 3.548 | 9.12 | 4.42 | 13.54 |
| 4 | 4.500 | 0.237 | 4.026 | 10.80 | 5.70 | 16.50 |
| 5 | 5.563 | 0.258 | 5.047 | 14.63 | 8.95 | 23.58 |
| 6 | 6.625 | 0.280 | 6.065 | 18.99 | 12.93 | 31.92 |
| 8 | 8.625 | 0.322 | 7.981 | 28.58 | 22.38 | 50.96 |
| 10 | 10.750 | 0.365 | 10.020 | 40.52 | 35.28 | 75.80 |

| Trapeze Span | NFPA 13 Required Trapeze Section Modulus for Sch 40 Pipe | | | | | | | | | | | |
|--------------|--|------|------|------|------|------|------|------|------|------|------|------|
| | Pipe Diameter | | | | | | | | | | | |
| | 1" | 1¼" | 1½" | 2" | 2½" | 3" | 3½" | 4" | 5" | 6" | 8" | 10" |
| 1' - 6" | 0.08 | 0.09 | 0.09 | 0.10 | 0.11 | 0.12 | 0.13 | 0.15 | 0.18 | 0.22 | 0.30 | 0.41 |
| 2' - 0" | 0.11 | 0.12 | 0.12 | 0.13 | 0.15 | 0.16 | 0.18 | 0.20 | 0.24 | 0.29 | 0.40 | 0.55 |
| 2' - 6" | 0.14 | 0.15 | 0.15 | 0.16 | 0.18 | 0.21 | 0.22 | 0.25 | 0.30 | 0.36 | 0.50 | 0.68 |
| 3' - 0" | 0.17 | 0.18 | 0.18 | 0.20 | 0.22 | 0.25 | 0.27 | 0.30 | 0.36 | 0.43 | 0.60 | 0.82 |
| 4' - 0" | 0.22 | 0.24 | 0.24 | 0.26 | 0.29 | 0.33 | 0.36 | 0.40 | 0.48 | 0.58 | 0.80 | 1.09 |
| 5' - 0" | 0.28 | 0.29 | 0.30 | 0.33 | 0.37 | 0.41 | 0.45 | 0.49 | 0.60 | 0.72 | 1.00 | 1.37 |
| 6' - 0" | 0.34 | 0.35 | 0.36 | 0.39 | 0.44 | 0.49 | 0.54 | 0.59 | 0.72 | 0.87 | 1.20 | 1.64 |
| 7' - 0" | 0.39 | 0.41 | 0.43 | 0.46 | 0.51 | 0.58 | 0.63 | 0.69 | 0.84 | 1.01 | 1.41 | 1.92 |
| 8' - 0" | 0.45 | 0.47 | 0.49 | 0.52 | 0.59 | 0.66 | 0.72 | 0.79 | 0.96 | 1.16 | 1.61 | 2.19 |
| 9' - 0" | 0.50 | 0.53 | 0.55 | 0.59 | 0.66 | 0.74 | 0.81 | 0.89 | 1.08 | 1.30 | 1.81 | 2.46 |
| 10' - 0" | 0.56 | 0.59 | 0.61 | 0.65 | 0.74 | 0.82 | 0.90 | 0.99 | 1.20 | 1.44 | 2.01 | 2.74 |

Values taken from NFPA 13 (1996 Edition), Table 2-6.1.5(a)

| Trapeze Span | Single Channel Trapeze for Sch 40 Pipe | | | | | | | | | | | |
|--------------|--|-------|-------|-------|-------|-------|-------|-------|-------|-------|-------|-------|
| | Pipe Diameter | | | | | | | | | | | |
| | 1" | 1¼" | 1½" | 2" | 2½" | 3" | 3½" | 4" | 5" | 6" | 8" | 10" |
| 1' - 6" | P3000 | P3000 | P3000 | P3000 | P3000 | P3000 | P3000 | P3000 | P1000 | P5500 | P5500 | P5000 |
| 2' - 0" | P3000 | P3000 | P3000 | P3000 | P3000 | P1000 | P1000 | P1000 | P5500 | P5500 | P5000 | P5000 |
| 2' - 6" | P3000 | P3000 | P3000 | P1000 | P1000 | P5500 | P5500 | P5500 | P5500 | P5500 | P5000 | N/A |
| 3' - 0" | P1000 | P1000 | P1000 | P1000 | P5500 | P5500 | P5500 | P5500 | P5500 | P5000 | P5000 | N/A |
| 4' - 0" | P5500 | P5500 | P5500 | P5500 | P5500 | P5500 | P5500 | P5000 | P5000 | P5000 | N/A | N/A |
| 5' - 0" | P5500 | P5500 | P5500 | P5500 | P5500 | P5000 | P5000 | P5000 | P5000 | N/A | N/A | N/A |
| 6' - 0" | P5500 | P5500 | P5500 | P5500 | P5000 | P5000 | P5000 | P5000 | N/A | N/A | N/A | N/A |
| 7' - 0" | P5500 | P5000 | P5000 | P5000 | P5000 | P5000 | N/A | N/A | N/A | N/A | N/A | N/A |
| 8' - 0" | P5000 | P5000 | P5000 | P5000 | P5000 | N/A | N/A | N/A | N/A | N/A | N/A | N/A |
| 9' - 0" | P5000 | P5000 | P5000 | P5000 | N/A | N/A | N/A | N/A | N/A | N/A | N/A | N/A |
| 10' - 0" | P5000 | P5000 | P5000 | N/A | N/A | N/A | N/A | N/A | N/A | N/A | N/A | N/A |

| Trapeze Span | Double Channel Trapeze for Sch 40 Pipe | | | | | | | | | | | |
|--------------|--|-------|-------|-------|-------|-------|-------|-------|-------|-------|-------|-------|
| | Pipe Diameter | | | | | | | | | | | |
| | 1" | 1¼" | 1½" | 2" | 2½" | 3" | 3½" | 4" | 5" | 6" | 8" | 10" |
| 1' - 6" | P3001 | P3001 | P3001 | P3001 | P3001 | P3001 | P3001 | P3001 | P3001 | P3001 | P3001 | P3001 |
| 2' - 0" | P3001 | P3001 | P3001 | P3001 | P3001 | P3001 | P3001 | P3001 | P3001 | P3001 | P3001 | P1001 |
| 2' - 6" | P3001 | P3001 | P3001 | P3001 | P3001 | P3001 | P3001 | P3001 | P3001 | P3001 | P1001 | P5501 |
| 3' - 0" | P3001 | P3001 | P3001 | P3001 | P3001 | P3001 | P3001 | P3001 | P3001 | P3001 | P5501 | P5501 |
| 4' - 0" | P3001 | P3001 | P3001 | P3001 | P3001 | P3001 | P3001 | P3001 | P1001 | P5501 | P5501 | P5501 |
| 5' - 0" | P3001 | P3001 | P3001 | P3001 | P3001 | P3001 | P1001 | P1001 | P5501 | P5501 | P5501 | P5001 |
| 6' - 0" | P3001 | P3001 | P3001 | P3001 | P1001 | P1001 | P1001 | P5501 | P5501 | P5501 | P5001 | P5001 |
| 7' - 0" | P3001 | P3001 | P3001 | P1001 | P1001 | P5501 | P5501 | P5501 | P5501 | P5501 | P5001 | N/A |
| 8' - 0" | P1001 | P1001 | P1001 | P1001 | P5501 | P5501 | P5501 | P5501 | P5501 | P5001 | P5001 | N/A |
| 9' - 0" | P1001 | P1001 | P1001 | P5501 | P5501 | P5501 | P5501 | P5501 | P5501 | P5001 | N/A | N/A |
| 10' - 0" | P1001 | P5501 | P5501 | P5501 | P5501 | P5501 | P5501 | P5501 | P5001 | P5001 | N/A | N/A |



ELECTRICAL METALLIC TUBING (EMT) - THIN WALL

| Tubing Size (Nominal) In | Outside Diameter In (mm) | Inside Diameter In (mm) | Weight Of Tubing Lbs/Ft (kg/m) |
|--------------------------|--------------------------|-------------------------|--------------------------------|
| 3/8 | 0.577 | 0.497 | 0.23 |
| | 14.7 | 12.6 | 0.34 |
| 1/2 | 0.706 | 0.626 | 0.29 |
| | 17.9 | 15.9 | 0.43 |
| 3/4 | 0.922 | 0.830 | 0.44 |
| | 23.4 | 21.1 | 0.65 |
| 1 | 1.163 | 1.055 | 0.64 |
| | 29.5 | 26.8 | 0.95 |
| 1 1/4 | 1.510 | 1.388 | 0.95 |
| | 38.4 | 35.3 | 1.41 |
| 1 1/2 | 1.740 | 1.618 | 1.10 |
| | 44.2 | 41.1 | 1.64 |
| 2 | 2.197 | 2.075 | 1.40 |
| | 55.8 | 52.7 | 2.08 |
| 2 1/2 | 2.875 | 2.731 | 2.30 |
| | 73.0 | 69.4 | 3.42 |
| 3 | 3.500 | 3.356 | 2.70 |
| | 88.9 | 85.2 | 4.02 |
| 3 1/2 | 4.000 | 3.834 | 3.40 |
| | 101.6 | 97.4 | 5.06 |
| 4 | 4.500 | 4.334 | 4.00 |
| | 114.3 | 110.1 | 5.95 |

INTERMEDIATE METALLIC CONDUIT (IMC)

| Conduit Size (Nominal) In | Outside Diameter In (mm) | Inside Diameter In (mm) | Weight Of Conduit Lbs/Ft (kg/m) | Weight of Conduit and Conductor Lbs/Ft (kg/m) |
|---------------------------|--------------------------|-------------------------|---------------------------------|---|
| 1/2 | 0.815 | 0.745 | 0.60 | 0.12 |
| | 20.7 | 18.9 | 0.89 | 0.18 |
| 3/4 | 1.029 | 0.954 | 0.82 | 1.13 |
| | 26.1 | 24.2 | 1.22 | 1.68 |
| 1 | 1.290 | 1.205 | 1.16 | 1.82 |
| | 32.8 | 30.6 | 1.73 | 2.71 |
| 1 1/4 | 1.638 | 1.553 | 1.50 | 2.67 |
| | 41.6 | 39.4 | 2.23 | 3.97 |
| 1 1/2 | 1.883 | 1.793 | 1.82 | 3.42 |
| | 47.8 | 45.5 | 2.71 | 5.09 |
| 2 | 2.360 | 2.266 | 2.42 | 5.04 |
| | 59.9 | 57.6 | 3.60 | 7.50 |
| 2 1/2 | 2.857 | 2.727 | 4.01 | 7.75 |
| | 72.6 | 69.3 | 5.97 | 11.53 |
| 3 | 3.476 | 3.346 | 4.43 | 10.69 |
| | 88.3 | 85.0 | 6.59 | 15.91 |
| 3 1/2 | 3.971 | 3.841 | 5.73 | 13.46 |
| | 100.9 | 97.6 | 8.53 | 20.03 |
| 4 | 4.466 | 4.336 | 6.38 | 16.37 |
| | 113.4 | 110.1 | 9.49 | 24.36 |

COPPER TUBE (TYPE L)

| Nom. Tube Size | O.D. Tubing In (mm) | O.D. In (mm) | Wall Thick. In (mm) | Weight Lbs/Ft (kg/m) | Weight Water Lbs/Ft (kg/m) |
|----------------|---------------------|--------------|---------------------|----------------------|----------------------------|
| 1/4" | 3/8 | 0.375 | 0.030 | 0.126 | 0.034 |
| | 10 | 9.5 | 0.8 | 0.19 | 0.05 |
| 3/8" | 1/2 | 0.500 | 0.035 | 0.198 | 0.062 |
| | 13 | 12.7 | 0.9 | 0.29 | 0.09 |
| 1/2" | 5/8 | 0.625 | 0.040 | 0.285 | 0.100 |
| | 16 | 15.9 | 1.0 | 0.42 | 0.15 |
| 5/8" | 3/4 | 0.750 | 0.042 | 0.362 | 0.151 |
| | 19 | 19.1 | 1.1 | 0.54 | 0.22 |
| 3/4" | 7/8 | 0.875 | 0.045 | 0.455 | 0.209 |
| | 22 | 22.2 | 1.1 | 0.68 | 0.31 |
| 1" | 1 1/8 | 1.125 | 0.050 | 0.655 | 0.357 |
| | 29 | 28.6 | 1.3 | 0.97 | 0.53 |
| 1 1/4" | 1 1/4 | 1.375 | 0.055 | 0.884 | 0.546 |
| | 35 | 34.9 | 1.4 | 1.32 | 0.81 |
| 1 1/2" | 1 5/8 | 1.625 | 0.060 | 1.140 | 0.767 |
| | 41 | 41.3 | 1.5 | 1.70 | 1.14 |
| 2" | 2 1/8 | 2.125 | 0.070 | 1.750 | 1.341 |
| | 54 | 54.0 | 1.8 | 2.60 | 2.00 |
| 2 1/2" | 2 5/8 | 2.625 | 0.080 | 2.480 | 2.064 |
| | 67 | 66.7 | 2.0 | 3.69 | 3.07 |
| 3" | 3 1/8 | 3.125 | 0.090 | 3.330 | 2.949 |
| | 79 | 79.4 | 2.3 | 4.96 | 4.39 |
| 3 1/2" | 3 5/8 | 3.625 | 0.100 | 4.290 | 3.989 |
| | 92 | 92.1 | 2.5 | 6.38 | 5.94 |
| 4" | 4 1/8 | 4.125 | 0.110 | 5.380 | 5.188 |
| | 105 | 104.8 | 2.8 | 8.01 | 7.72 |
| 5" | 5 1/8 | 5.125 | 0.125 | 7.610 | 8.081 |
| | 130 | 130.2 | 3.2 | 11.32 | 12.03 |
| 6" | 6 1/8 | 6.125 | 0.140 | 10.200 | 11.616 |
| | 156 | 155.6 | 3.6 | 15.18 | 17.29 |
| 8" | 8 1/8 | 8.125 | 0.200 | 19.290 | 20.289 |
| | 206 | 206.4 | 5.1 | 28.71 | 30.19 |
| 10" | 10 3/8 | 10.125 | 0.250 | 30.100 | 31.590 |
| | 257 | 257.2 | 6.4 | 44.79 | 47.01 |
| 12" | 12 3/8 | 12.125 | 0.280 | 40.400 | 45.426 |
| | 308 | 308.0 | 7.1 | 60.12 | 67.60 |

COPPER TUBE (TYPE K)

| Nom. Tube Size | O.D. Tubing In (mm) | O.D. In (mm) | Wall Thick. In (mm) | Weight Lbs/Ft (kg/m) | Weight Water Lbs/Ft (kg/m) |
|----------------|---------------------|--------------|---------------------|----------------------|----------------------------|
| 1/4" | 3/8 | 0.375 | 0.035 | 0.145 | 0.032 |
| | 10 | 9.53 | 0.89 | 0.22 | 0.05 |
| 3/8" | 1/2 | 0.500 | 0.005 | 0.269 | 0.055 |
| | 13 | 12.70 | 0.13 | 0.40 | 0.08 |
| 1/2" | 5/8 | 0.625 | 0.049 | 0.344 | 0.094 |
| | 16 | 15.88 | 1.24 | 0.51 | 0.14 |
| 5/8" | 3/4 | 0.750 | 0.049 | 0.418 | 0.144 |
| | 19 | 19.05 | 1.24 | 0.62 | 0.21 |
| 3/4" | 7/8 | 0.875 | 0.065 | 0.641 | 0.188 |
| | 22 | 22.23 | 1.65 | 0.95 | 0.28 |
| 1" | 1 1/8 | 1.125 | 0.065 | 0.839 | 0.337 |
| | 29 | 28.58 | 1.65 | 1.25 | 0.50 |
| 1 1/4" | 1 1/4 | 1.375 | 0.065 | 1.040 | 0.527 |
| | 35 | 34.93 | 1.65 | 1.55 | 0.78 |
| 1 1/2" | 1 5/8 | 1.625 | 0.072 | 1.360 | 0.743 |
| | 41 | 41.28 | 1.83 | 2.02 | 1.11 |
| 2" | 2 1/8 | 2.125 | 0.083 | 2.060 | 1.310 |
| | 54 | 53.98 | 2.11 | 3.07 | 1.95 |
| 2 1/2" | 2 5/8 | 2.625 | 0.095 | 2.920 | 2.000 |
| | 67 | 66.68 | 2.41 | 4.35 | 2.98 |
| 3" | 3 1/8 | 3.125 | 0.109 | 4.000 | 2.960 |
| | 79 | 79.38 | 2.77 | 5.95 | 4.40 |
| 3 1/2" | 3 5/8 | 3.625 | 0.120 | 5.120 | 3.900 |
| | 92 | 92.08 | 3.05 | 7.62 | 5.80 |
| 4" | 4 1/8 | 4.125 | 0.134 | 6.510 | 5.060 |
| | 105 | 104.78 | 3.40 | 9.69 | 7.53 |
| 5" | 5 1/8 | 5.125 | 0.160 | 9.670 | 8.000 |
| | 130 | 130.18 | 4.06 | 14.39 | 11.91 |
| 6" | 6 1/8 | 6.125 | 0.192 | 13.870 | 11.200 |
| | 156 | 155.58 | 4.88 | 20.64 | 16.67 |
| 8" | 8 1/8 | 8.125 | 0.271 | 25.900 | 19.500 |
| | 206 | 206.38 | 6.88 | 38.54 | 29.02 |
| 10" | 10 3/8 | 10.125 | 0.338 | 40.300 | 30.423 |
| | 257 | 257.18 | 8.59 | 59.97 | 45.27 |
| 12" | 12 3/8 | 12.125 | 0.405 | 57.800 | 43.675 |
| | 308 | 307.98 | 10.29 | 86.02 | 65.00 |

RIGID STEEL (HEAVY DUTY) CONDUIT

| Conduit Size (Nominal) In | I. D. Of Conduit In (mm) | O. D. Of Conduit In (mm) | O. D. Of Coupling In (mm) | Weight of Conduit Lbs/Ft (kg/m) | Maximum Weight* Of Conduit And Conductor Lead Covered Lbs/Ft (kg/m) | Not Lead Covered Lbs/Ft (kg/m) |
|---------------------------|--------------------------|--------------------------|---------------------------|---------------------------------|---|--------------------------------|
| 1/2 | 0.622 15.8 | 0.840 21.3 | 1.063 27.0 | 0.85 1.26 | 1.20 1.79 | 1.00 1.49 |
| 3/4 | 0.824 20.9 | 1.050 26.7 | 1.297 32.9 | 1.13 1.68 | 1.80 2.68 | 1.40 2.08 |
| 1 | 1.049 26.6 | 1.315 33.4 | 1.563 39.7 | 1.68 2.50 | 2.60 3.87 | 2.30 3.42 |
| 1 1/4 | 1.380 35.1 | 1.660 42.2 | 1.969 50.0 | 2.28 3.39 | 4.30 6.40 | 3.60 5.36 |
| 1 1/2 | 1.610 40.9 | 1.900 48.3 | 2.234 56.7 | 2.73 4.06 | 5.90 8.78 | 4.50 6.70 |
| 2 | 2.067 52.5 | 2.375 60.3 | 2.719 69.1 | 3.68 5.48 | 8.50 12.65 | 7.20 10.71 |
| 2 1/2 | 2.469 62.7 | 2.875 73.0 | 3.313 84.2 | 5.82 8.66 | 11.50 17.11 | 10.20 15.18 |
| 3 | 3.068 77.9 | 3.500 88.9 | 3.938 100.0 | 7.62 11.34 | 16.50 24.55 | 14.50 21.58 |
| 3 1/2 | 3.548 90.1 | 4.000 101.6 | 4.438 112.7 | 9.20 13.69 | 19.00 28.28 | 17.50 26.04 |
| 4 | 4.026 102.3 | 4.500 114.3 | 4.938 125.4 | 10.89 16.21 | 24.80 36.91 | 21.50 32.00 |
| 5 | 5.047 128.2 | 5.563 141.3 | 6.296 159.9 | 14.81 22.04 | 35.90 53.43 | 30.80 45.84 |
| 6 | 6.065 154.1 | 6.625 168.3 | 7.358 186.9 | 19.19 28.56 | 50.70 75.45 | 43.40 64.59 |

* Maximum weight equals weight of rigid conduit plus weight of heaviest conductor combination (from the National Electrical Code Handbook.)

| Nominal Pipe Size In | Max. Span Ft (m) | Nominal Pipe Size In | Max. Span Ft (m) |
|----------------------|------------------|----------------------|------------------|
| 1 | 7 2.13 | 8 | 19 5.79 |
| 1 1/2 | 9 2.74 | 10 | 22 6.71 |
| 2 | 10 3.05 | 12 | 23 7.01 |
| 2 1/2 | 11 3.35 | 14 | 25 7.62 |
| 3 | 12 3.66 | 16 | 27 8.23 |
| 3 1/2 | 13 3.96 | 18 | 28 8.53 |
| 4 | 14 4.27 | 20 | 30 9.14 |
| 5 | 16 4.88 | 24 | 32 9.75 |

The above spacing based on a combined bending and shear stress of 1500 PSI when pipe is filled with water and the pitch of the line is such that a sag of 0.1 in. between supports is permissible.

CONDUIT SUPPORTS

346-12. Supports. Rigid metal conduit shall be installed as a complete system as provided in Article 344 and shall be securely fastened in place. Conduit shall be firmly fastened within 3 feet (914 mm) of each outlet box, junction box, cabinet, or fitting. Conduit shall be supported at least every 10 feet (3.05 m).

Exception: If made up with threaded couplings, it shall be permissible to support straight runs of rigid metal conduit in accordance with Table 344.30 (B)(2), provided such supports prevent transmission of stresses to termination where conduit is deflected between supports.

Table 344.30 (B)(2)
Support for Rigid Metal Conduit

| Conduit Size In (mm) | Maximum Distance Between Supports Ft (m) |
|----------------------|--|
| 1/2-3/4 | 10 |
| 13 - 19 | 3.05 |
| 1 | 12 |
| 25 | 3.66 |
| 1 1/4- 1 1/2 | 14 |
| 32 - 38 | 4.27 |
| 2- 2 1/2 | 16 |
| 51 - 64 | 4.88 |
| 3 & larger | 20 |
| 76 - Larger | 6.10 |

SCHEDULE 40: PVC PLASTIC PIPE

| Pipe Size (Nominal) In | Outside Diameter In (mm) | Inside Diameter In (mm) | Pipe Weight Lbs/Ft (kg/m) | Pipe and Water Weight Lbs/Ft (kg/m) |
|------------------------|--------------------------|-------------------------|---------------------------|-------------------------------------|
| 1/4 | 0.540 13.7 | 0.354 9.0 | 0.081 0.12 | 0.12 0.18 |
| 3/8 | 0.675 17.1 | 0.483 12.3 | 0.109 0.16 | 0.19 0.28 |
| 1/2 | 0.840 21.3 | 0.608 15.4 | 0.161 0.24 | 0.29 0.43 |
| 3/4 | 1.050 26.7 | 0.810 20.6 | 0.214 0.32 | 0.44 0.65 |
| 1 | 1.315 33.4 | 1.033 26.2 | 0.315 0.47 | 0.68 1.01 |
| 1 1/4 | 1.660 42.2 | 1.364 34.6 | 0.426 0.63 | 1.06 1.58 |
| 1 1/2 | 1.900 48.3 | 1.592 40.4 | 0.509 0.76 | 1.37 2.04 |
| 2 | 2.375 60.3 | 2.049 52.0 | 0.682 1.01 | 2.11 3.14 |
| 2 1/2 | 2.875 73.0 | 2.445 62.1 | 1.076 1.60 | 3.11 4.63 |
| 3 | 3.500 88.9 | 3.042 77.3 | 1.409 2.10 | 4.55 6.77 |
| 4 | 4.500 114.3 | 3.998 101.5 | 2.006 2.99 | 7.44 11.07 |
| 6 | 6.625 168.3 | 6.031 153.2 | 3.535 5.26 | 15.90 23.66 |
| 8 | 8.625 219.1 | 7.943 201.8 | 5.305 7.89 | 26.75 39.81 |
| 10 | 10.750 273.1 | 9.976 253.4 | 7.532 11.21 | 41.35 61.54 |

1 1/2" Channel
Telesruct System
Nuts & Hardware
General Fittings
Pipe/Conduit Supports
Electrical Fittings
Concrete Inserts
1 1/2" Framing System
1 3/4" Framing System
Fiberglass System
Special Metals
PrimeAngle System
Product Index



DATA FOR SCHEDULE STEEL PIPE

| Nom. Size In | Pipe Schedule | Outside Dia. In (mm) | Inside Dia. In (mm) | Pipe Weight Lbs/Ft (kg/m) | Pipe and Water Weight Lbs/Ft (kg/m) |
|--------------|---------------|----------------------|---------------------|---------------------------|-------------------------------------|
| 1/8 | 40 | 0.405 10.3 | 0.269 6.8 | 0.24 0.36 | 0.27 0.40 |
| | 80 | 0.405 10.3 | 0.215 5.5 | 0.31 0.46 | 0.33 0.49 |
| 1/4 | 40 | 0.540 13.7 | 0.364 9.2 | 0.42 0.63 | 0.47 0.70 |
| | 80 | 0.540 13.7 | 0.302 7.7 | 0.53 0.79 | 0.57 0.85 |
| 3/8 | 40 | 0.675 17.1 | 0.493 12.5 | 0.57 0.85 | 0.65 0.97 |
| | 80 | 0.675 17.1 | 0.423 10.7 | 0.74 1.10 | 0.80 1.19 |
| 1/2 | 40 | 0.840 21.3 | 0.622 15.8 | 0.85 1.26 | 0.98 1.46 |
| | 80 | 0.840 21.3 | 0.546 13.9 | 1.09 1.62 | 1.19 1.77 |
| | 160 | 0.840 21.3 | 0.464 11.8 | 1.31 1.95 | 1.38 2.05 |
| 3/4 | 40 | 1.050 26.7 | 0.824 20.9 | 1.13 1.68 | 1.36 2.02 |
| | 80 | 1.050 26.7 | 0.742 18.8 | 1.47 2.19 | 1.66 2.47 |
| | 160 | 1.050 26.7 | 0.612 15.5 | 1.94 2.89 | 2.07 3.08 |
| 1 | 40 | 1.315 33.4 | 1.049 26.6 | 1.68 2.50 | 2.05 3.05 |
| | 80 | 1.315 33.4 | 0.957 24.3 | 2.17 3.23 | 2.48 3.69 |
| | 160 | 1.315 33.4 | 0.815 20.7 | 2.84 4.23 | 3.07 4.57 |
| 1 1/4 | 40 | 1.660 42.2 | 1.380 35.1 | 2.27 3.38 | 2.92 4.35 |
| | 80 | 1.660 42.2 | 1.278 32.5 | 2.99 4.45 | 3.55 5.28 |
| | 160 | 1.660 42.2 | 1.160 29.5 | 3.76 5.60 | 4.22 6.28 |
| 1 1/2 | 40 | 1.900 48.3 | 1.610 40.9 | 2.71 4.03 | 3.60 5.36 |
| | 80 | 1.900 48.3 | 1.500 38.1 | 3.63 5.40 | 4.39 6.53 |
| | 160 | 1.900 48.3 | 1.338 34.0 | 4.85 7.22 | 5.46 8.13 |
| 2 | 40 | 2.375 60.3 | 2.067 52.5 | 3.65 5.43 | 5.10 7.59 |
| | 80 | 2.375 60.3 | 1.939 49.3 | 5.02 7.47 | 6.30 9.38 |
| | 160 | 2.375 60.3 | 1.687 42.8 | 7.45 11.09 | 8.42 12.53 |
| 2 1/2 | 40 | 2.875 73.0 | 2.469 62.7 | 5.79 8.62 | 7.86 11.70 |
| | 80 | 2.875 73.0 | 2.323 59.0 | 7.65 11.38 | 9.49 14.12 |
| | 160 | 2.875 73.0 | 2.125 54.0 | 10.00 14.88 | 11.54 17.17 |
| 3 | 40 | 3.500 88.9 | 3.068 77.9 | 7.57 11.27 | 10.77 16.03 |
| | 80 | 3.500 88.9 | 2.900 73.7 | 10.24 15.24 | 13.11 19.51 |
| | 160 | 3.500 88.9 | 2.624 66.6 | 14.31 21.30 | 16.65 24.78 |
| 3 1/2 | 40 | 4.000 101.6 | 3.548 90.1 | 9.10 13.54 | 13.39 19.93 |
| | 80 | 4.000 101.6 | 3.364 85.4 | 12.49 18.59 | 16.35 24.33 |

| Nom. Size In | Pipe Schedule | Outside Dia. In (mm) | Inside Dia. In (mm) | Pipe Weight Lbs/Ft (kg/m) | Pipe and Water Weight Lbs/Ft (kg/m) |
|--------------|---------------|----------------------|---------------------|---------------------------|-------------------------------------|
| 4 | 40 | 4.500 114.3 | 4.026 102.3 | 10.78 16.04 | 16.30 24.26 |
| | 80 | 4.500 114.3 | 3.826 97.2 | 14.97 22.28 | 19.95 29.69 |
| | 120 | 4.500 114.3 | 3.624 92.0 | 18.98 28.25 | 23.45 34.90 |
| | 160 | 4.500 114.3 | 3.438 87.3 | 22.48 33.45 | 26.51 39.45 |
| 5 | 40 | 5.563 141.3 | 5.047 128.2 | 14.60 21.73 | 23.27 34.63 |
| | 80 | 5.563 141.3 | 4.813 122.2 | 20.75 30.88 | 28.64 42.62 |
| | 120 | 5.563 141.3 | 4.563 115.9 | 27.01 40.20 | 34.09 50.73 |
| | 160 | 5.563 141.3 | 4.313 109.5 | 32.92 48.99 | 39.26 58.43 |
| 6 | 40 | 6.625 168.3 | 6.065 154.1 | 18.95 28.20 | 31.48 46.85 |
| | 80 | 6.625 168.3 | 5.761 146.3 | 28.54 42.47 | 39.84 59.29 |
| | 120 | 6.625 168.3 | 5.501 139.7 | 36.35 54.09 | 46.66 69.44 |
| | 160 | 6.625 168.3 | 5.187 131.7 | 45.30 67.41 | 54.47 81.06 |
| | 20 | 8.625 219.1 | 8.125 206.4 | 22.34 33.25 | 44.82 66.70 |
| | 30 | 8.625 219.1 | 8.071 205.0 | 24.67 36.71 | 46.85 69.72 |
| 8 | 40 | 8.625 219.1 | 7.981 202.7 | 28.52 42.44 | 50.21 74.72 |
| | 60 | 8.625 219.1 | 7.813 198.5 | 35.60 52.98 | 56.39 83.92 |
| | 80 | 8.625 219.1 | 7.625 193.7 | 43.34 64.50 | 63.14 93.96 |
| | 100 | 8.625 219.1 | 7.437 188.9 | 50.89 75.73 | 69.73 103.77 |
| | 120 | 8.625 219.1 | 7.187 182.5 | 60.65 90.26 | 78.23 116.42 |
| | 140 | 8.625 219.1 | 7.001 177.8 | 67.68 100.72 | 84.37 125.56 |
| | 160 | 8.625 219.1 | 6.813 173.1 | 74.61 111.03 | 90.42 134.56 |
| | 20 | 10.750 273.1 | 10.250 260.4 | 28.01 41.68 | 63.78 94.92 |
| 10 | 30 | 10.750 273.1 | 10.136 257.5 | 34.20 50.90 | 69.19 102.97 |
| | 40 | 10.750 273.1 | 10.020 254.5 | 40.44 60.18 | 74.63 111.06 |
| | 60 | 10.750 273.1 | 9.750 247.7 | 54.68 81.37 | 87.05 129.54 |
| | 80 | 10.750 273.1 | 9.562 242.9 | 64.36 95.78 | 95.50 142.12 |
| | 100 | 10.750 273.1 | 9.312 236.5 | 76.95 114.51 | 106.47 158.44 |
| | 120 | 10.750 273.1 | 9.062 230.2 | 89.20 132.74 | 117.16 174.35 |
| | 140 | 10.750 273.1 | 8.750 222.3 | 104.02 154.80 | 130.09 193.60 |
| | 160 | 10.750 273.1 | 8.500 215.9 | 115.52 171.91 | 140.13 208.54 |

Product Index
 PrimeAngle System
 Special Metals
 Fiberglass System
 1 3/16" Framing System
 1 1/4" Framing System
 Concrete Inserts
 Electrical Fittings
 Pipe/Conduit Supports
 General Fittings
 Nuts & Hardware
 Telestrut System
 Channel
 1 5/8"

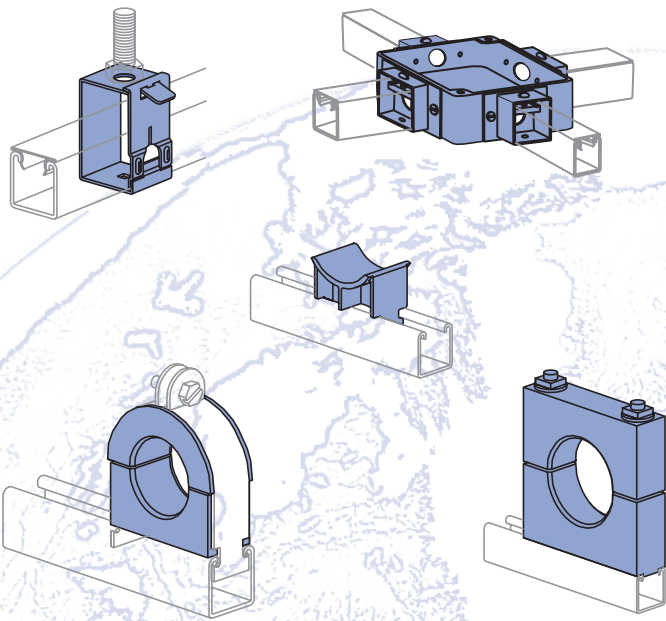

| | |
|--|---------|
| Electrical Fittings..... | 122-124 |
| Receptacles..... | 124-125 |
| Fixture Hangers..... | 125 |
| Accessories and Connectors..... | 125-126 |
| Junction Boxes..... | 126 |
| In-Channel Joiners..... | 127 |
| Swivel Hangers..... | 127 |
| Cable Entrance Tubing and Accessories..... | 128-130 |
| Electrical Fittings Technical Data..... | 131-132 |

MATERIAL

Unistrut fittings, unless noted, are made from hot-rolled, pickled and oiled steel plates, strip or coil, and conform to ASTM specifications A575, A576, A635, or A36. The fitting steel also meets the physical requirements of ASTM A1011 SS GR 33. The pickling of the steel produces a smooth surface free from scale.

Maple cable saddles, cable clamps and bus bar clamps are made from kiln-dry maple treated with paraffin to a depth of $\frac{1}{16}$ " (1.6mm). Special sizes of clamps can be fabricated upon request. Porcelain cable clamps are made by the dry process and white glazed. Cable saddles are fiberglass-reinforced polyester.

CHANNEL RACEWAYS

The Unistrut Metal Framing System includes an exclusive combination of channel, fittings and hardware listed under new UL classification 5B. This classification covers strut-type channel raceways and fittings for use in accordance with Article 384 of the National Electrical Code, NFPA 70. Included are metal strut-type channel raceways at least .071 inch (1.81mm) thick and metal or non-metal closure strips at least .040 inch (1.02mm) thick.

The Unistrut system requires no welding, drilling or other complex fabrication techniques. This means faster, easier solutions for virtually any electrical support problem.

Unistrut channel offers structural and spanning capabilities not available with conventional surface raceway products and is available in continuous lengths of up to 20 feet. Just as important, it is part of an integrated system that can be used for raceways, trapeze hangers, cable-tray supports, lighting grids, fluorescent-fixture supports and countless other electrical applications.

CHANNEL COMPATABILITY

All of the electrical components in this section are intended for use with any of the $1\frac{5}{8}$ " wide channel. They are not intended for use with $1\frac{1}{4}$ " or $1\frac{3}{16}$ " framing systems.

FINISHES

Components listed in this section are available in:

- Electro-galvanized (EG), conforming to ASTM B633 Type III SC1;
- Hot-dipped galvanized (HG), conforming to ASTM A123 or A153,
- Perma-Green III (GR),
- Plain (PL).

Note: Many Unistrut Metal Framing components, when used with appropriate closures, are UL® listed, and CSA approved.

DESIGN LOAD

Design load data, where shown, is based on the ultimate strength of the connection with a safety factor of 2.5, unless otherwise noted.

DIMENSIONS

Imperial dimensions are illustrated in inches. Metric dimensions are shown in parenthesis or as noted. Unless noted, all metric dimensions are in millimeters and rounded to one decimal place.

LISTINGS

| | |
|-----------------------|--------------------------|
| UL File No. - E19459 | Channel & Closure Strips |
| UL File No. - E25629 | Fittings |
| CSA File No. - 013669 | All Products |



Electrical Fittings

1 5/8" Channel

Telesrnut System

Nuts & Hardware

General Fittings

Pipe/Conduit Supports

Electrical Fittings

Concrete Inserts

1 1/4" Framing System

1 3/8" Framing System

Fiberglass System

Special Metals

PrimeAngle System

Product Index

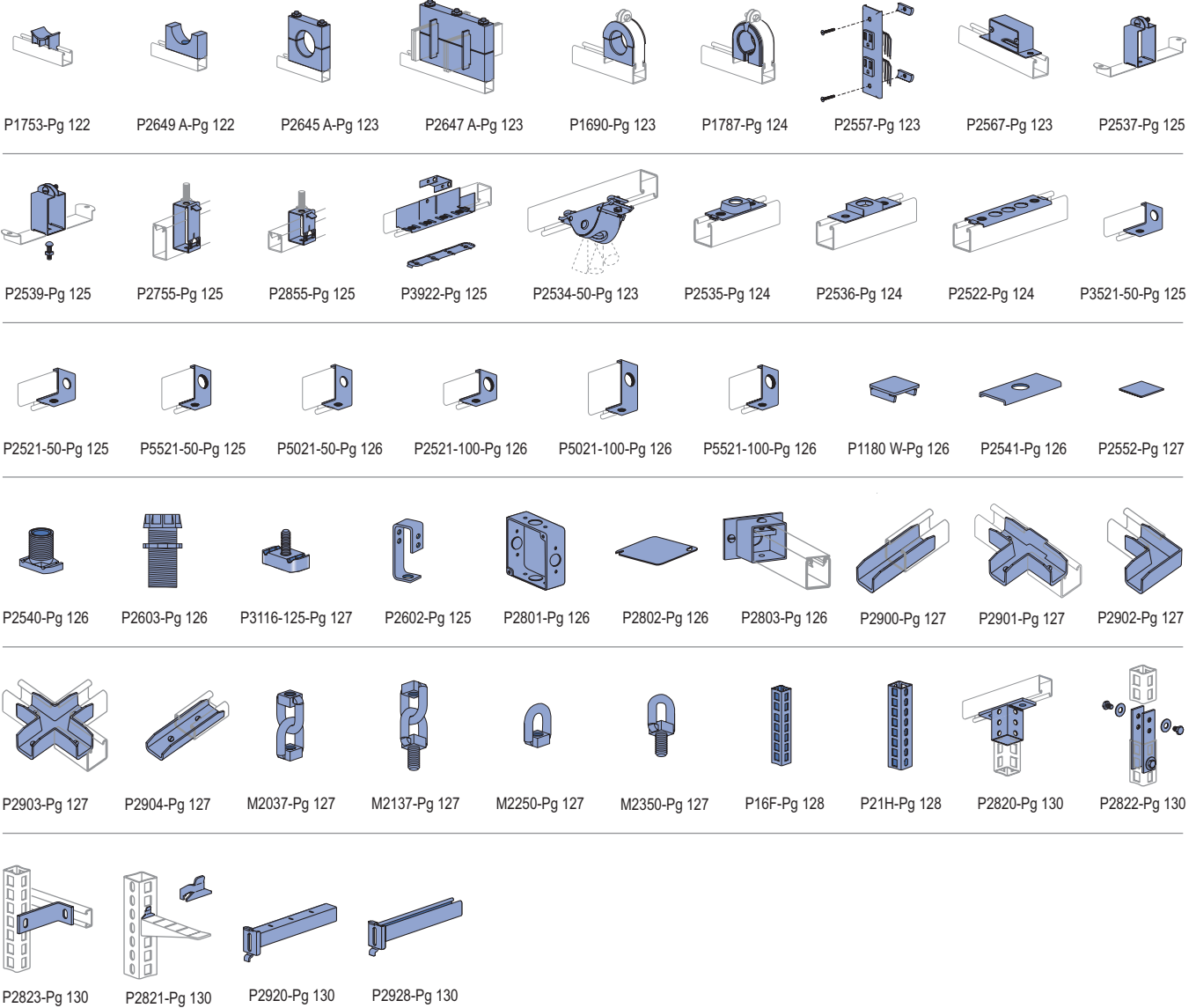

P2649A THRU P2649H

MAPLE CABLE SADDLES

P1753, P1754

CABLE SADDLES

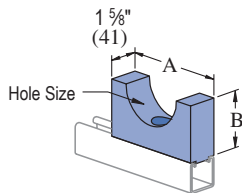

- 3/8" Flat Head Machine Screw included.
 - Specify hole size when ordering.
 - Order channel nuts as required.
- Material: Maple hardwood paraffin impregnated.

| Part No. | Hole Size In (mm) | "A" In (mm) | "B" In (mm) | Wt/100 pcs Lbs (kg) |
|----------|----------------------|----------------|----------------|------------------------|
| P2649A | 0 - 1 | 3 | 1 3/4 | 31 |
| | 0 - 25 | 76 | 45 | 14.1 |
| P2649B | 1 - 1 1/2 | 3 1/2 | 2 | 38 |
| | 25 x 38 | 89 | 51 | 17.2 |
| P2649C | 1 1/2 - 2 | 4 | 2 1/4 | 47 |
| | 38 - 51 | 102 | 57 | 21.3 |
| P2649D | 2 - 2 1/2 | 4 1/2 | 2 1/2 | 57 |
| | 51 x 64 | 114 | 65 | 25.9 |
| P2649E | 2 1/2 - 3 | 5 | 2 3/4 | 68 |
| | 64 - 76 | 127 | 70 | 30.8 |
| P2649F | 3 - 3 1/2 | 5 1/2 | 3 | 80 |
| | 76 x 89 | 140 | 76 | 36.3 |
| P2649G | 3 1/2 - 4 | 6 | 3 1/4 | 94 |
| | 89 - 102 | 152 | 83 | 42.6 |
| P2649H | over 4 | | | |
| | over 102 | | | |

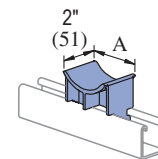

| Part Number | "A" In (mm) | Maximum Cable Dia. In (mm) | Wt/100 pcs Lbs (kg) |
|-------------|----------------|-------------------------------|------------------------|
| P1753 FG | 2 13/16 | 3 | 12 |
| | 71 | 76 | 5.4 |
| P1754 FG | 3 3/4 | 4 1/2 | 17 |
| | 95 | 114 | 7.7 |
| P1753 PO | 3 | 3 | 75 |
| | 76 | 76 | 34.0 |
| P1754 PO | 4 | 4 1/2 | 95 |
| | 102 | 114 | 43.1 |

Material: FG - Fiberglass Reinforced Polyester, PO - Dry Process White Glazed Porcelain

P2645A THRU P2645H

MAPLE CABLE CLAMPS

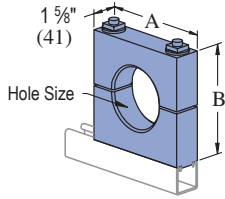

| Part No. | Hole Size In (mm) | "A" & "B" Dimensions In (mm) | Wt/100 pcs Lbs (kg) |
|----------|---------------------|------------------------------|---------------------|
| P2645A | 0 - 1 0 - 25 | 3½ 89 | 84 38.1 |
| P2645B | 1 - 1½ 25 x 38 | 4 102 | 102 46.3 |
| P2645C | 1½ - 2 38 - 50.8 | 4½ 114 | 121 54.9 |
| P2645D | 2 - 2½ 51 x 64 | 5½ 140 | 165 74.8 |
| P2645E | 2½ - 3 64 - 76 | 6 152 | 189 85.7 |
| P2645F | 3 - 3½ 76 x 89 | 6½ 165 | 215 97.5 |
| P2645G | 3½ - 4 89 - 102 | 7 178 | 243 110.2 |
| P2645H | over 4 over 102 | - | - |

- 3/8" studs, square nuts and washers included.
 - Specify hole size when ordering.
 - Order channel nuts as required.
- Material: Maple hardwood paraffin impregnated.

P2647A THRU P2647F

4" (101.6) BUS BAR MAPLE CLAMPS

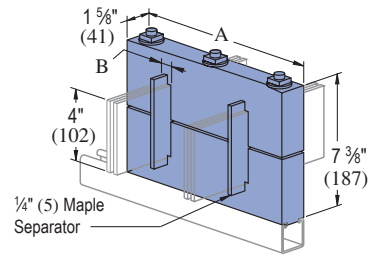

- 1/2" studs, square nuts and washers are included.
 - Channel nuts must be ordered separately.
 - Bus bar maple clamps also available in 1/4" (6.4) x 2" (50.8) and 1/4" (6.4) x 6" (152.4).
- Material: Paraffin impregnated maple hardwood.

| Part No. | "A" In (mm) | "B" In (mm) | No. Bus Separators | No. Bars Per Leg | Wt/100 pcs Lbs (kg) |
|----------|-------------|--------------|--------------------|------------------|---------------------|
| P2647A | 8½ 216 | 3/32 7.1 | 0 | 1 | 421 191.0 |
| P2647B | 9½ 241 | 13/16 21 | 2 | 2 | 465 210.9 |
| P2647C | 10½ 267 | 15/16 33 | 4 | 3 | 509 230.9 |
| P2647D | 11½ 292 | 113/16 46 | 6 | 4 | 553 250.8 |
| P2647E | 12½ 318 | 23/8 60 | 8 | 5 | 597 270.8 |
| P2647F | 13½ 343 | 27/8 73 | 10 | 6 | 631 286.2 |

P1690 THRU P1697

MAPLE CABLE CLAMPS

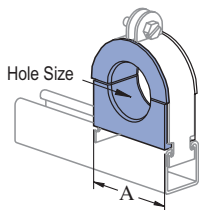

| Part No. | Steel Clamp No. | Hole Size In (mm) | "A" In (mm) | Wt/100 pcs Lbs (kg) |
|----------|-----------------|--------------------|-------------|---------------------|
| P1690 | P1113 E | 0 - 5/8 0 - 16 | 1½ 38 | 24 10.9 |
| P1691 | P1115 E | ½ - 1 13 - 25 | 2½ 54 | 42 19.1 |
| P1692 | P1117 E | ¾ - 1½ 19 x 38 | 25/8 67 | 54 24.5 |
| P1693 | P1118 E | 1¼ - 1¾ 32 x 45 | 3 76 | 65 29.5 |
| P1694 | P1119 E | 1½ - 2¼ 38 x 57 | 35/8 92 | 84 38.1 |
| P1695 | P1120 E | 2 - 2½ 51 x 65 | 4½ 105 | 107 48.5 |
| P1696 | P1121 E | 2¼ - 3 57 - 76 | 45/8 118 | 123 55.8 |
| P1697 | P1123 E | 3 - 4 76 - 102 | 5¾ 146 | 163 73.9 |

- Use with steel clamp and Everdur hardware. Order clamp separately.
 - Specify hole size when ordering.
- Material: Paraffin impregnated maple hardwood.

P2557

DUPLEX GROUNDED RECEPTACLE

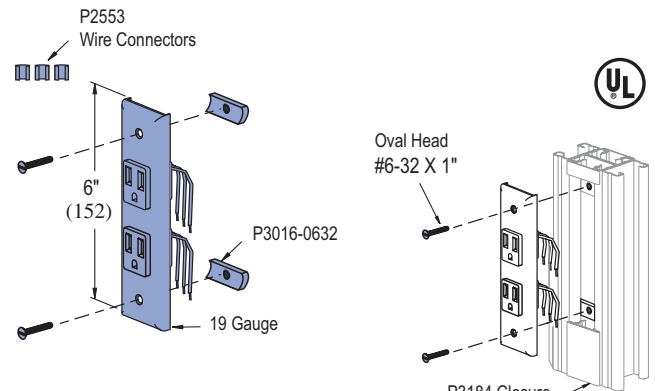

- Finish: White powder coat.
- 125 V, 15 amp receptacle, NEMA configuration 5-15R, cover plate.
 - #6 screws, nuts and wire connectors included.
 - Leads are 14 gauge 105°C plastic covered.
 - Ground wire is green 16 gauge.

Wt/100 pcs: 38 Lbs (17.2 kg)

P2534-50, P2534-75

CONDUIT SWING FITTING

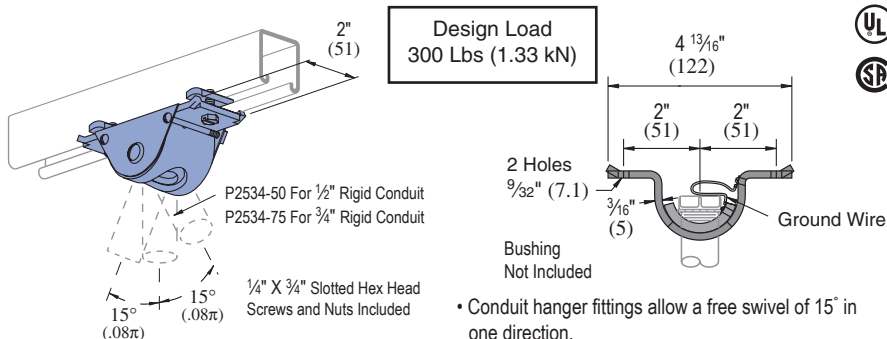

Design Load
300 Lbs (1.33 kN)

2 Holes
9/32" (7.1)

Bushing
Not Included

Ground Wire

- Conduit hanger fittings allow a free swivel of 15° in one direction.
- Fitting may be mounted to the slot side of the Unistrut channel or to the back.

Wt/100 pcs: 96 Lbs (43.5 kg)

P2567

OUTLET BOX

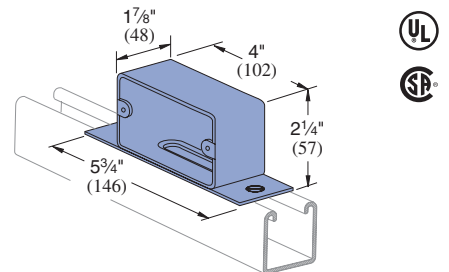

Material: 14 Gauge (.075)
Assembly: 1 Box, 2 Screws, 2 Channel Nuts

Wt/100 pcs: 88 Lbs (47.8 kg)

15/16" Channel
Telesnut System
Nuts & Hardware
General Fittings
Pipe/Conduit Supports
Electrical Fittings
Concrete Inserts
1 1/4" Framing System
1 3/16" Framing System
Fiberglass System
Special Metals
PrimeAngle System
Product Index



P1787 THRU P1795

PORCE-A-CLAMP™

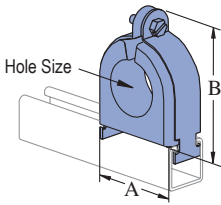

Patents Pending
 Strap Material: Electro-galvanized Steel (EG) or Stainless Steel (SS)
 Use With: All 1 1/2" channel

Porce-A-Clamp™

- Non-Breakable TPE Material.
- U.V. Resistant.
- U.L. Listed.
- Optional Stainless Steel Clamps.
- Tapered Flange to Protect Cable.
- Dielectric Strength 640 Volts Per Mil.
- One Piece Insulator.
- Replaces Porcelain & Maple Cable Clamp.
- For use in accordance with National Electrical Code ANSI/NFPA 70.
- Includes Pipe Strap.
- Temperature Rating -50°F to +275°F (-45°C to +135°C)

| Part Number | Hole Size In (mm) | "A" In (mm) | "B" In (mm) | Wt/100 pcs Lbs (kg) |
|-------------|----------------------|----------------|----------------|------------------------|
| P1787A | 3/8 10 | 1.36 35 | 1.82 46 | 25 11.3 |
| P1787B | 1/2 13 | | | |
| P1787C | 5/8 16 | | | |
| P1788 | 3/4 19 | 1.86 47 | 2.34 59 | 37 16.8 |
| P1788A | 7/8 22 | | | |
| P1788B | 1 25 | | | |
| P1788C | 1 1/8 29 | | | |
| P1789 | 1 1/4 32 | 2.36 60 | 2.86 73 | 58 16.8 |
| P1789A | 1 3/8 35 | | | |
| P1789B | 1 1/2 38 | | | |
| P1789C | 1 5/8 41 | 2.86 73 | 3.50 89 | 76 34.5 |
| P1790 | 1 3/4 45 | | | |
| P1790A | 1 7/8 48 | | | |
| P1790B | 2 51 | 3.36 85 | 4.05 103 | 90 40.8 |
| P1790C | 2 1/8 54 | | | |
| P1791 | 2 1/4 57 | 3.36 85 | 4.05 103 | 90 40.8 |
| P1791A | 2 3/8 60 | | | |

| Part Number | Hole Size In (mm) | "A" In (mm) | "B" In (mm) | Wt/100 pcs Lbs (kg) |
|-------------|----------------------|----------------|----------------|------------------------|
| P1791B | 2 1/2 64 | 3.36 85 | 4.05 103 | 90 40.8 |
| P1791C | 2 5/8 67 | | | |
| P1792 | 2 3/4 70 | 3.86 98 | 4.75 121 | 109 49.4 |
| P1792A | 2 7/8 73 | | | |
| P1792B | 3 76 | | | |
| P1792C | 3 1/8 79 | 4.36 111 | 5.125 130 | 130 59.0 |
| P1793 | 3 1/4 83 | | | |
| P1793A | 3 3/8 86 | | | |
| P1793B | 3 1/2 89 | 4.86 184 | 5.54 141 | 160 72.6 |
| P1793C | 3 5/8 92 | | | |
| P1794 | 3 3/4 95 | 5.24 133 | 5.92 150 | 160 72.6 |
| P1794A | 3 7/8 98 | | | |
| P1794B | 4 102 | | | |
| P1794C | 4 1/8 105 | 5.24 133 | 5.92 150 | 160 72.6 |
| P1795 | 4 1/4 108 | | | |
| P1795A | 4 3/8 111 | 5.24 133 | 5.92 150 | 160 72.6 |
| P1795B | 4 1/2 114 | | | |

P2535 CONDUIT HANGER CONNECTION FOR 1/2" CONDUIT

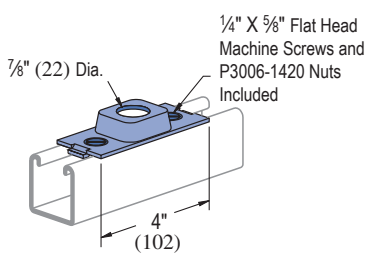

Design Load
400 Lbs (1.78 kN)

Material: 12 gauge (2.7).

Wt/100 pcs: 28 Lbs (12.7 kg)

P2536 CONDUIT HANGER CONNECTION FOR 3/4" CONDUIT

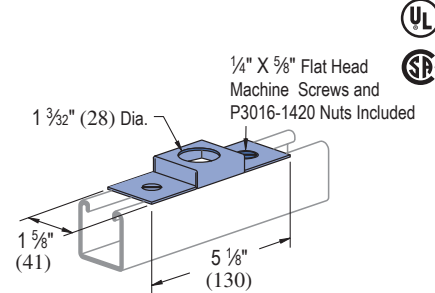

Design Load
200 Lbs (0.89 kN)

Material: 16 gauge (1.5)

Wt/100 pcs: 36 Lbs (16.3 kg)

P2522 OUTLET BOX CONNECTION

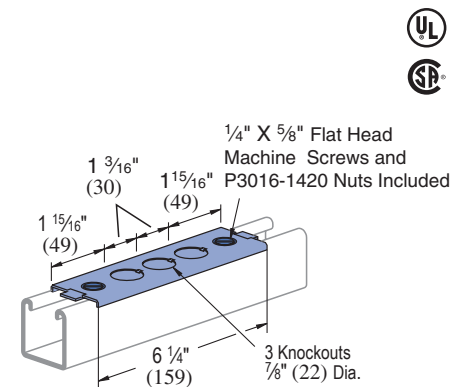

Wt/100 pcs: 35 Lbs (15.9 kg)

P2755, P2756, P2757

RACEWAY HANGERS

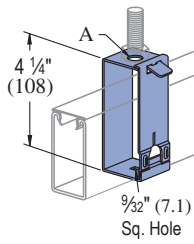

Design Load
120 Lbs (0.53 kN)

| Part No. | "A" In (mm) | Wt/100 pcs Lbs (kg) |
|----------|-----------------|---------------------|
| P2755 | 9/16 14 | 44 20.0 |
| P2756 | 7/8 22 | 44 20.0 |
| P2757 | 1 13/32 10.3 | 44 20.0 |

Use with Channels:
P1001, P1101, P2001,
P5000, & P5500.
Material: 14 gauge (1.9).

P2855, P2856, P2857

RACEWAY HANGERS

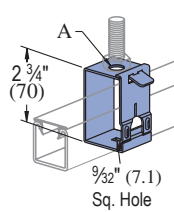

Design Load
120 Lbs (0.53 kN)

| Part No. | "A" In (mm) | Wt/100 pcs Lbs (kg) |
|----------|-----------------|---------------------|
| P2855 | 9/16 14 | 32 14.5 |
| P2856 | 7/8 22 | 32 14.5 |
| P2857 | 1 13/32 10.3 | 32 14.5 |

Use with Channels:
P1000, P1100,
P3000, P3300
Material: 14 gauge (1.9).

P2537, P5537

FLUORESCENT FIXTURE HANGERS

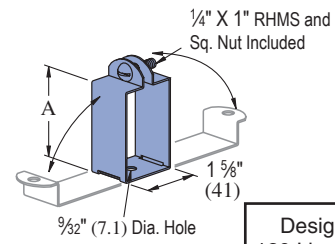

Design Load
120 Lbs (0.53 kN)

• Hanger provides more than 1/2" (12.7) space between channel and fixtures.
Materials: 18 gauge (1.2).

| Part No. | Use w/Channel | "A" In (mm) | Wt/100 pcs Lbs (kg) |
|----------|---------------|-------------|---------------------|
| P2537 | P1000 | 2 7/16 | 19 |
| | P1100 | 61.9 | 8.6 |
| | P3000 | | |
| P5537 | P5500 | 3 1/4 | 22 |
| | | 82.6 | 10.0 |

P2602

MERCURY VAPOR FIXTURE HANGER

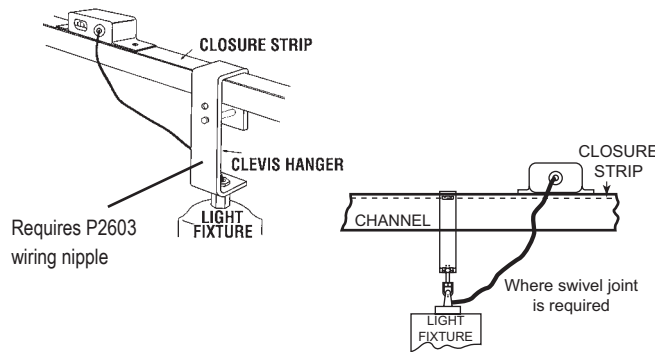
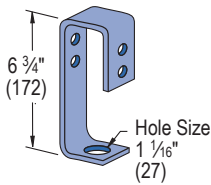

Requires P2603 wiring nipple

Wt/100 pcs: 154 Lbs (69.9 kg)

Use with 1 5/8" Channel
Finish: Electro-galvanized
Stock Size: 1/4"
NOTE: Supports fixture in slot up or down system.

P2539, P3539, P5539

FLUORESCENT FIXTURE HANGERS

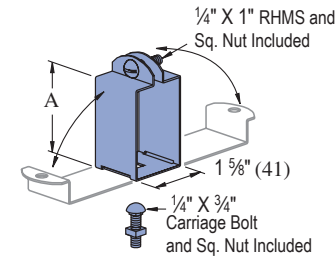

• Hanger provides 1/8" (3.2) space between channel and fixtures.
Materials: 18 gauge (1.2).

| Part No. | Use w/Channel | "A" In (mm) | Wt/100 pcs Lbs (kg) |
|----------|---------------|-------------|---------------------|
| P2539 | P1000 | 1 1/4 | 17 |
| | P1100 | 45 | 7.7 |
| P3539 | P3000 | 1 1/2 | 15 |
| P5539 | P3000 | 38 | 6.8 |
| | P5500 | 2 9/16 | 18 |
| | | 65 | 8.2 |

P3922 THRU P3926

SPLICE FITTINGS

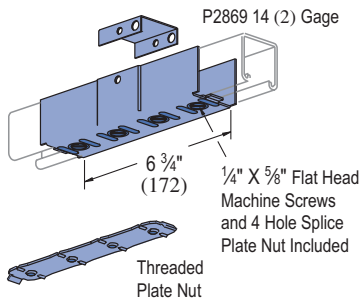

| Assy. No. | Use W/ Channel | "A" In (mm) | Clevis No. | Back Clevis No. | Plate Nut No. | Wt/100 pcs Lbs (kg) |
|-----------|----------------|-------------|------------|-----------------|---------------|---------------------|
| P3922 | P1000 | 1 5/8 | P2377 | P2517 | P2869 | 100 |
| | P1100 | 41 | | | | 45.4 |
| P3923 | P3000 | 1 3/8 | P3377 | P2517 | P2869 | 97 |
| P3924 | P4000 | 1 13/16 | P5377 | P2517 | P2869 | 80 |
| | | 21 | | | | 36.3 |
| P3925 | P5500 | 1 1/8 | P2377 | P5517 | P2869 | 103 |
| P3926 | P5000 | 41 | | | | 46.7 |
| | | 1 5/8 | P2377 | P5017 | P2869 | 106 |
| | | 41 | | | | 48.1 |

Material: 16 gauge (1.6).

P3521-50

END CONNECTORS FOR 1/2" CONDUIT

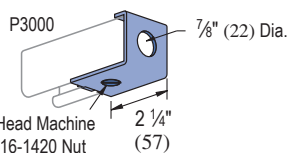

1/4" X 5/8" Flat Head Machine Screw and P3016-1420 Nut Included

Material: 12 gauge (3).

Wt/100 pcs: 27 Lbs (12.2 kg)

P5251-50, P2521-75

END CONNECTORS FOR 1/2" & 3/4" CONDUIT



1/4" X 5/8" Flat Head Machine Screw and P3016-1420 Nut Included

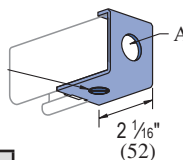

| Part No. | Conduit Size In | Wt/100 pcs Lbs (kg) |
|----------|-----------------|---------------------|
| P2521-50 | 1/2 | 27 12.2 |
| P2521-75 | 3/4 | 26 11.8 |

Use with channels:
P1000 and P1100.
Material:
12 gauge (3)

P5521-50, P5521-75

END CONNECTORS FOR 1/2" & 3/4" CONDUIT



1/4" X 5/8" Flat Head Machine Screw and P3016-1420 Nut Included

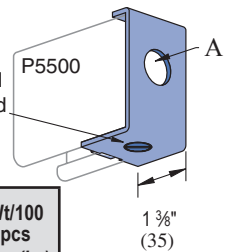

| Part No. | Conduit Size In | Wt/100 pcs Lbs (kg) |
|----------|-----------------|---------------------|
| P5521-50 | 1/2 | 27 12.2 |
| P5521-75 | 3/4 | 26 11.8 |

Material:
12 gauge (3).



P5021-50, P5021-75 END CONNECTOR FOR 1/2" & 3/4" CONDUIT

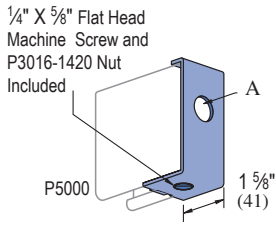

| Part No. | Conduit Size A In | Wt/100 pcs Lbs (kg) |
|----------|-------------------|---------------------|
| P5021-50 | 1/2 | 31 14.1 |
| P5021-75 | 3/4 | 30 13.6 |

Material: 12 gauge (2.7).

P2521-100 END CONNECTOR FOR 1" CONDUIT

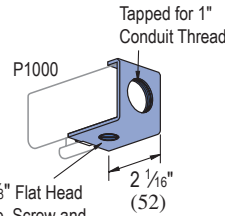

1/4" X 5/8" Flat Head Machine Screw and P3016-1420 Nut Included

Material: 12 gauge (2.7).

Wt/100 pcs: 24 Lbs (10.9 kg)

P5021-100 END CONNECTOR FOR 1" CONDUIT

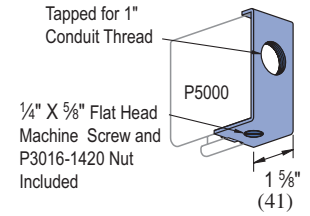

1/4" X 5/8" Flat Head Machine Screw and P3016-1420 Nut Included

Material: 12 gauge (2.7).

Wt/100 pcs: 28 Lbs (12.7 kg)

P5521-100 END CONNECTOR FOR 1" CONDUIT

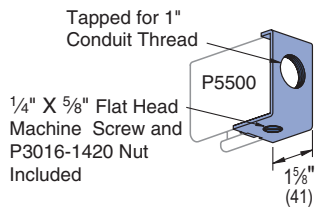

Material: 12 gauge (2.7).

Wt/100 pcs: 24 Lbs (10.9 kg)

P2541

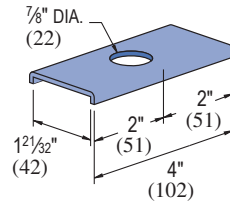

Material: 12 gauge (2.7).

Wt/100 pcs: 24 Lbs (10.9 kg)

SPACER CLEVIS



P1180W THRU P5580 END CAPS

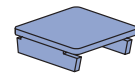

Material: 14 gauge (1.9)

| Part Number | Use With | Wt/100 pcs Lbs (kg) |
|-------------|----------|---------------------|
| P1180W | P1100 | 12 (5.4) |
| P1280W | P1000 | 11 (5.0) |
| P2280W | P2000 | 11 (5.0) |
| P3280W | P3000 | 8 (3.6) |
| P4280W | P4000 | 5 (2.3) |
| P5280W | P5000 | 22 (10.0) |
| P5580W | P5500 | 18 (8.2) |

P2603 FIXTURE WIRING NIPPLE

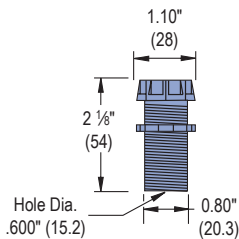

Assembly: 1/2" x 2" rigid conduit nipple Bushing Locknut

Wt/100 pcs: 14 Lbs (6.4 kg)

P2540, P2540A

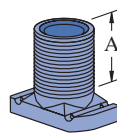

Stamped Ident. No.
P2540 – 121961
P2540A – 121960
Material: Sintered metal.

1/2" American Standard Straight Pipe Thread

| Part No. | "A" In (mm) | Wt/100 pcs Lbs (kg) |
|----------|-------------|---------------------|
| P2540 | 1 5/64 | 10.0 |
| | 29 | 4.5 |
| P2540A | 5/8 | 8 |
| | 16 | 3.6 |

Design Load
320 Lbs (1.42 kN)

WIRING STUD NUT



P2802 JUNCTION BOX COVER

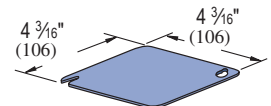

Wt/100 pcs: 30 Lbs (13.6kg)

P2803

Stamp ID No. 122022

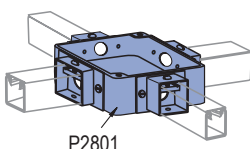
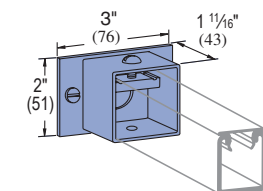

P2801

Wt/100 pcs: 32 Lbs (14.5 kg)

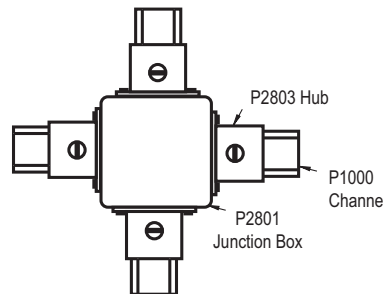

Note: Combine junction box (P2801) and hub assemblies (P2803) to make 1, 2, 3, or 4 way junction box.



P2801 JUNCTION BOX

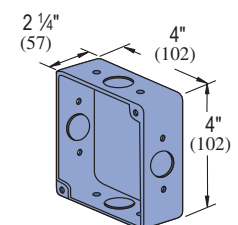

Wt/100 pcs: 113 Lbs (51.4 kg)



P3116-125
FIXTURE STUD NUT

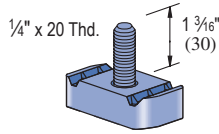

Wt/100 pcs: 11 Lbs (5.0 kg)

P2552

POLYPROPYLENE WIRE RETAINER

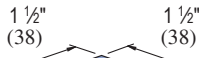

Retainer may be easily pushed into channel to support wires until closure strip is installed.

Wt/100 pcs: .30 Lbs (.1 kg)

P2904



P3300, P4000, P4100

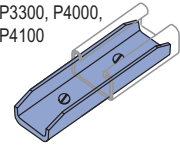

3/8"-16 x 1/4" Socket Cup Point
Set Screws Included
Extruded Aluminum

Wt/100 pcs: 12 Lbs (5.4kg)

P2900

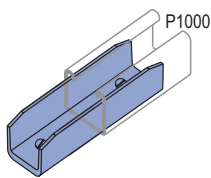

3/8"-16 x 1/4"
Socket Cup Point
Set Screws Included
Material: Cast aluminum.

Wt/100 pcs: 20 Lbs (9.1 kg)

P2901

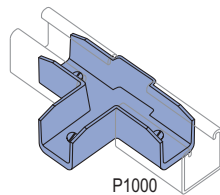

3/8"-16 x 1/4"
Socket Cup Point
Set Screws Included
Material: Cast aluminum.

Wt/100 pcs: 35 Lbs (15.9 kg)

P2902

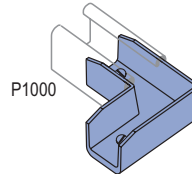

3/8"-16 x 1/4"
Socket Cup Point
Set Screws Included
Material: Cast aluminum.

Wt/100 pcs: 27 Lbs (12.2 kg)

P2903

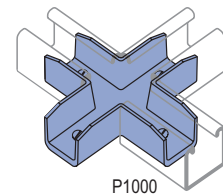

3/8"-16 x 1/4"
Socket Cup Point
Set Screws Included
Material: Cast aluminum.

Wt/100 pcs: 45 Lbs (20.4 kg)

M2037, M2050

SWIVEL HANGERS

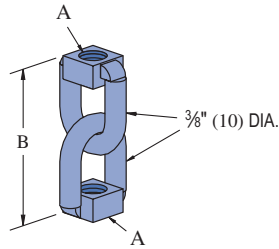

Design Load
600 Lbs (2.67 kN)

| Part No. | "A" In | "B" In (mm) | Wt/100 pcs Lbs (kg) |
|----------|-----------|---------------------------------------|---------------------|
| M2037 | 3/8" - 16 | 2 ³¹ / ₃₂ 75 | 23 10.4 |
| M2050 | 1/2" - 13 | 2 ³ / ₄ 70 | 32 14.5 |

M2250

SWIVEL HANGER

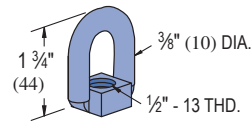

Design Load
600 Lbs (2.67 kN)

Wt/100 pcs: 18 Lbs (8.2 kg)

M2137, M2150

SWIVEL HANGERS

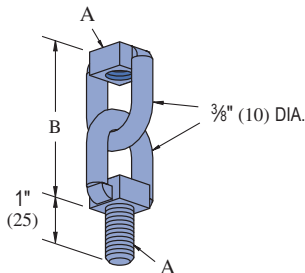

Design Load
600 Lbs (2.67 kN)

| Part No. | "A" In | "B" In (mm) | Wt/100 pcs Lbs (kg) |
|----------|-----------|---------------------------------------|---------------------|
| M2137 | 3/8" - 16 | 2 ²⁹ / ₃₂ 74 | 27 12.2 |
| M2150 | 1/2" - 13 | 2 ³ / ₄ 70 | 45 20.4 |

M2350

SWIVEL HANGER

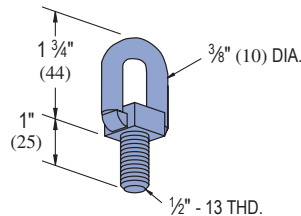

Design Load
600 Lbs (2.67 kN)

Wt/100 pcs: 20 Lbs (9.1 kg)



P16F

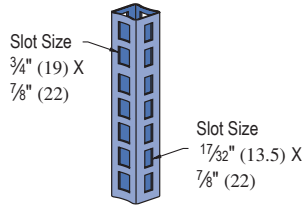

Slot spacing
1 1/4" (31.8)
on center.

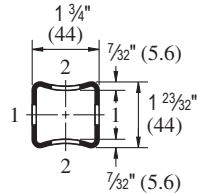

Tubing Finishes: PL, GR, HG, PG;
Standard Lengths: 10' & 20'

Wt/100 Ft: 178 Lbs (260 kg/100 m)
Allowable Moment 4,800 In-Lbs (540 N·m)
12 Gauge Nominal Thickness .105" (2.7mm)

P21H

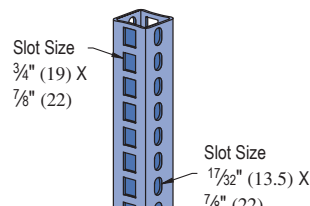

Slot spacing
1 1/4" (31.8)
on center.

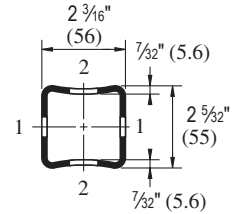

Tubing Finishes: PL, GR, HG, PG;
Standard Lengths: 10' & 20'

Wt/100 Ft: 297 Lbs (440 kg/100 m)
Allowable Moment 11,370 In-Lbs (540 N·m)
12 Gauge Nominal Thickness .105" (2.7mm)

P16F - COLUMN LOADING

| Unbraced Height In | Max. Allowable Load Column Loaded at C.G. Lbs | Max. Allowable Load Column Loaded at Slot Face Lbs |
|-----------------------|--|---|
| 24 | 9,600 | 3,300 |
| 36 | 9,000 | 3,100 |
| 48 | 8,300 | 2,900 |
| 60 | 7,500 | 2,700 |
| 72 | 6,600 | 2,400 |
| 84 | 5,600 | 2,200 |
| 96 | 4,500 | 1,900 |
| 108 | 3,600 | 1,600 |
| 120 | 2,900 | 1,400 |
| 144 | 2,000 | 1,100 |

P21H - COLUMN LOADING

| Unbraced Height In | Max. Allowable Load Column Loaded at C.G. Lbs | Max. Allowable Load Column Loaded at Slot Face Lbs |
|-----------------------|--|---|
| 24 | 17,700 | 6,200 |
| 36 | 16,900 | 6,000 |
| 48 | 16,000 | 5,700 |
| 60 | 15,000 | 5,400 |
| 72 | 13,900 | 5,100 |
| 84 | 12,600 | 4,700 |
| 96 | 11,300 | 4,300 |
| 108 | 9,900 | 3,900 |
| 120 | 8,300 | 3,500 |
| 144 | 5,800 | 2,800 |
| 168 | 4,230 | 2,300 |

P16F - COLUMN LOADING (METRIC)

| Unbraced Height mm | Max. Allowable Load Column Loaded at C.G. kN | Max. Allowable Load Column Loaded at Slot Face kN |
|-----------------------|---|--|
| 610 | 42.7 | 14.7 |
| 914 | 40.0 | 13.8 |
| 1,219 | 36.9 | 12.9 |
| 1,524 | 33.4 | 12.0 |
| 1,829 | 29.4 | 10.7 |
| 2,134 | 24.9 | 9.8 |
| 2,438 | 20.0 | 8.5 |
| 2,743 | 16.0 | 7.1 |
| 3,048 | 12.9 | 6.2 |
| 3,658 | 8.9 | 4.9 |

P21H - COLUMN LOADING (METRIC)

| Unbraced Height mm | Max. Allowable Load Column Loaded at C.G. kN | Max. Allowable Load Column Loaded at Slot Face kN |
|-----------------------|---|--|
| 610 | 78.7 | 27.6 |
| 914 | 75.2 | 26.7 |
| 1,219 | 71.2 | 25.4 |
| 1,524 | 66.7 | 24.0 |
| 1,829 | 61.8 | 22.7 |
| 2,134 | 56.0 | 20.9 |
| 2,438 | 50.3 | 19.1 |
| 2,743 | 44.0 | 17.3 |
| 3,048 | 36.9 | 15.6 |
| 3,658 | 25.8 | 12.5 |
| 4,267 | 18.8 | 10.2 |

1 1/2" Channel
 Telesnut System
 Nuts & Hardware
 General Fittings
 Pipe/Conduit Supports
 Electrical Fittings
 Concrete Inserts
 1 1/4" Framing System
 1 3/16" Framing System
 Fiberglass System
 Special Metals
 PrimeAngle System
 Product Index

P16F - BEAM LOADING

| Span In | Max Allowable Uniform Load Lbs | Defl. at Uniform Load In | Uniform Loading at Deflection | | |
|---------|--------------------------------|--------------------------|-------------------------------|--------------|--------------|
| | | | Span/180 Lbs | Span/240 Lbs | Span/360 Lbs |
| 24 | 1,600 | 0.06 | 1,600 | 1,600 | 1,600 |
| 36 | 1,070 | 0.13 | 1,070 | 1,070 | 820 |
| 48 | 800 | 0.23 | 800 | 690 | 460 |
| 60 | 640 | 0.36 | 590 | 440 | 290 |
| 72 | 530 | 0.52 | 410 | 310 | 200 |
| 84 | 460 | 0.71 | 300 | 220 | 150 |
| 96 | 400 | 0.93 | 230 | 170 | 110 |
| 108 | 360 | 1.18 | 180 | 140 | 90 |
| 120 | 320 | 1.45 | 150 | 110 | 70 |
| 144 | 270 | 2.09 | 100 | 80 | 50 |
| 168 | 230 | 2.85 | 70 | 60 | 40 |

P21H - BEAM LOADING

| Span In | Max Allowable Uniform Load Lbs | Defl. at Uniform Load In | Uniform Loading at Deflection | | |
|---------|--------------------------------|--------------------------|-------------------------------|--------------|--------------|
| | | | Span/180 Lbs | Span/240 Lbs | Span/360 Lbs |
| 24 | 3,790 | 0.05 | 3,790 | 3,790 | 3,790 |
| 36 | 2,530 | 0.11 | 2,530 | 2,530 | 2,380 |
| 48 | 1,900 | 0.19 | 1,900 | 1,900 | 1,340 |
| 60 | 1,520 | 0.29 | 1,520 | 1,280 | 860 |
| 72 | 1,260 | 0.42 | 1,190 | 890 | 590 |
| 84 | 1,080 | 0.58 | 870 | 660 | 440 |
| 96 | 950 | 0.76 | 670 | 500 | 330 |
| 108 | 840 | 0.96 | 530 | 400 | 260 |
| 120 | 760 | 1.18 | 430 | 320 | 210 |
| 144 | 630 | 1.70 | 300 | 220 | 150 |
| 168 | 540 | 2.31 | 220 | 160 | 110 |

P16F - BEAM LOADING (METRIC)

| Span mm | Max Allowable Uniform Load kN | Defl. at Uniform Load mm | Uniform Loading at Deflection | | |
|---------|-------------------------------|--------------------------|-------------------------------|-------------|-------------|
| | | | Span/180 kN | Span/240 kN | Span/360 kN |
| 600 | 7.2 | 1 | 7.2 | 7.2 | 7.2 |
| 750 | 5.8 | 2 | 5.8 | 5.8 | 5.4 |
| 1,000 | 4.3 | 4 | 4.3 | 4.3 | 3.0 |
| 1,250 | 3.5 | 6 | 3.5 | 2.9 | 1.9 |
| 1,500 | 2.9 | 9 | 2.7 | 2.0 | 1.4 |
| 1,750 | 2.5 | 12 | 2.0 | 1.5 | 1.0 |
| 2,000 | 2.2 | 16 | 1.5 | 1.1 | 0.8 |
| 2,500 | 1.7 | 25 | 1.0 | 0.7 | 0.5 |
| 3,000 | 1.5 | 36 | 0.7 | 0.5 | 0.3 |
| 3,500 | 1.2 | 49 | 0.5 | 0.4 | 0.2 |
| 4,000 | 1.1 | 64 | 0.4 | 0.3 | 0.2 |

P21H - BEAM LOADING (METRIC)

| Span mm | Max Allowable Uniform Load kN | Defl. at Uniform Load mm | Uniform Loading at Deflection | | |
|---------|-------------------------------|--------------------------|-------------------------------|-------------|-------------|
| | | | Span/180 kN | Span/240 kN | Span/360 kN |
| 600 | 17.1 | 1 | 17.1 | 17.1 | 17.1 |
| 750 | 13.7 | 2 | 13.7 | 13.7 | 13.7 |
| 1,000 | 10.3 | 3 | 10.3 | 10.3 | 8.8 |
| 1,250 | 8.2 | 5 | 8.2 | 8.2 | 5.7 |
| 1,500 | 6.9 | 7 | 6.9 | 5.9 | 3.9 |
| 1,750 | 5.9 | 10 | 5.8 | 4.3 | 2.9 |
| 2,000 | 5.1 | 13 | 4.4 | 3.3 | 2.2 |
| 2,500 | 4.1 | 20 | 2.8 | 2.1 | 1.4 |
| 3,000 | 3.4 | 29 | 2.0 | 1.5 | 1.0 |
| 3,500 | 2.9 | 40 | 1.4 | 1.1 | 0.7 |
| 4,000 | 2.6 | 52 | 1.1 | 0.8 | 0.5 |

Notes:

1. Above loads include the weight of the member. This weight must be deducted to arrive at the net allowable load the beam will support.
2. Long span beams should be supported in such a manner as to prevent rotation and twist.
3. Allowable uniformly distributed loads are listed for various simple spans, that is, a beam on two supports. If load is concentrated at the center of the span, multiply load from the table by 0.5 and corresponding deflection by 0.8.

P16F - ELEMENTS OF SECTION

| Parameter | P16F | P16F (metric) |
|------------------------|-----------------------|----------------------|
| Area of Section | 0.416 In ² | 2.68 cm ² |
| Axis 1-1 | | |
| Moment of Inertia (I) | 0.168 In ⁴ | 7.0 cm ⁴ |
| Section Modulus (S) | 0.192 In ³ | 3.1 cm ³ |
| Radius of Gyration (r) | 0.650 In | 1.7 cm |
| Axis 2-2 | | |
| Moment of Inertia (I) | 0.210 In ⁴ | 8.7 cm ⁴ |
| Section Modulus (S) | 0.240 In ³ | 3.9 cm ³ |
| Radius of Gyration (r) | 0.725 In | 1.8 cm |

P21H - ELEMENTS OF SECTION

| Parameter | P21H | P21H (metric) |
|------------------------|-----------------------|----------------------|
| Area of Section | 0.749 In ² | 4.83 cm ² |
| Axis 1-1 | | |
| Moment of Inertia (I) | 0.490 In ⁴ | 20.4 cm ⁴ |
| Section Modulus (S) | 0.455 In ³ | 7.5 cm ³ |
| Radius of Gyration (r) | 0.820 In | 2.1 cm |
| Axis 2-2 | | |
| Moment of Inertia (I) | 0.590 In ⁴ | 24.6 cm ⁴ |
| Section Modulus (S) | 0.540 In ³ | 8.8 cm ³ |
| Radius of Gyration (r) | 0.900 In | 2.3 cm |



P2820, P2940 CHANNEL/TUBE CONNECTORS

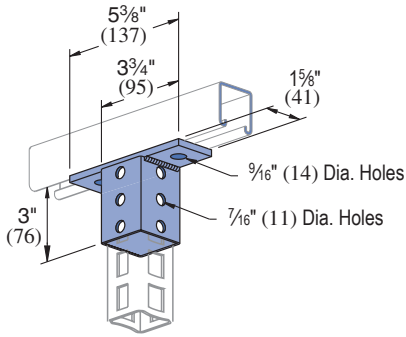

| Part No. | Use With | Wt/100 pcs Lbs (kg) |
|----------|----------|---------------------|
| P2820 | P16F | 116 (2.6) |
| P2940 | P21H | 148 (67.1) |

P2822, P2932

SPLICE FITTINGS

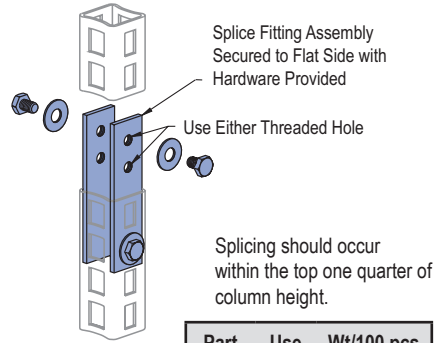

| Part No. | Use With | Wt/100 pcs Lbs (kg) |
|----------|----------|---------------------|
| P2822 | P16F | 97 (44.0) |
| P2932 | P21H | 122 (55.3) |

P2823

90° RACK FITTING

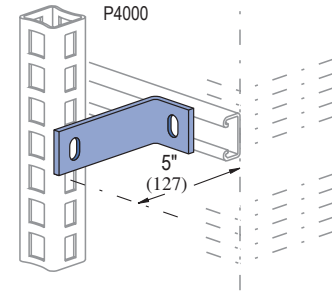

Wt/100 pcs: 66 Lbs (29.9 kg)

P2821

LOCKING CLIP

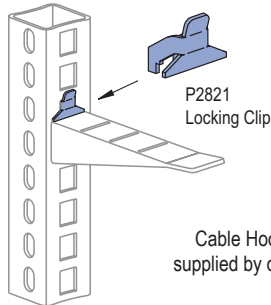

Exclusive Cable Hook
Locking Clip prevents Cable Hook removal.

Wt/100 pcs: 3 Lbs (1.4 kg)

P2928, P2929 AND P2930

CABLE BRACKETS

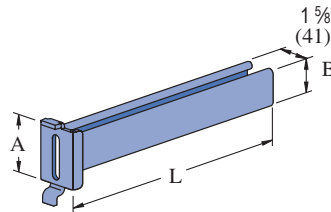

Use with P16F or P21H.

Material: 12 gauge steel.

| Part Number | "L" In (mm) | "A" In (mm) | "B" In (mm) | Wt/100 pcs Lbs (kg) | Uniform Design Load Lbs (kN) |
|-------------|-------------|-------------|-------------|---------------------|------------------------------|
| P2928 | 6 152 | 3 1/2 89 | 7/8 22 | 92 41.7 | 500 2.22 |
| P2929 | 12 305 | 3 1/2 89 | 1 5/8 41 | 320 145.1 | 250 1.12 |
| P2930 | 18 457 | 3 1/2 89 | 1 5/8 41 | 420 190.5 | 170 0.76 |

Safety factor of 3.

P2920 THRU P2924

CABLE BRACKETS

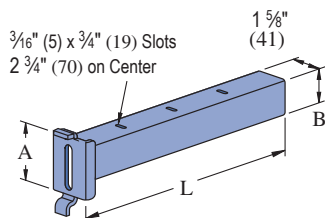

Use with P16F or P21H.

Material: 12 gauge steel.

| Part Number | "L" In (mm) | "A" In (mm) | "B" In (mm) | Wt/100 pcs Lbs (kg) | Uniform Design Load Lbs (kN) |
|-------------|---------------|-------------|-------------|---------------------|------------------------------|
| P2920 | 5 1/2 140 | 3 1/2 89 | 7/8 22 | 90 40.8 | 500 2.22 |
| P2921 | 8 1/4 210 | 3 1/2 89 | 7/8 22 | 120 54.4 | 325 1.45 |
| P2922 | 11 279 | 3 1/2 89 | 1 5/8 41 | 300 136.1 | 275 1.22 |
| P2923 | 13 3/4 349 | 3 1/2 89 | 1 5/8 41 | 340 154.2 | 220 0.98 |
| P2924 | 19 1/4 489 | 3 1/2 89 | 1 5/8 41 | 430 195.0 | 160 0.71 |

Safety factor of 3.

1 5/8" Channel
 Telestrut System
 Nuts & Hardware
 General Fittings
 Pipe/Conduit Supports
 Electrical Fittings
 Concrete Inserts
 1 1/4" Framing System
 1 3/16" Framing System
 Fiberglass System
 Special Metals
 PrimeAngle System
 Product Index

U.L. LISTED

Unistrut channel is listed by Underwriters' Laboratories as a surface metal raceway. Snap-in closure strip is used to complete the raceway. Accessory parts listed by Underwriters are noted on drawings.

The following tables represent maximum number of conductors when raceway is not employed with fixtures or where the clearance between fixtures and raceway is greater than 1/2" (12.7). In all cases the snap-in cover is required to complete raceway enclosure.

P3300

| Gauge | Number and Conductor Size (AWG) | | | | |
|------------|---------------------------------|----|----|---|---|
| | 14 | 12 | 10 | 8 | 6 |
| THWN, THHN | 40 | 30 | 19 | 9 | 6 |
| XHHW | 26 | 21 | 16 | 7 | 5 |
| T, TW | 26 | 20 | 15 | 7 | 4 |
| THW | 17 | 14 | 11 | 6 | 4 |
| RH | 15 | 12 | 7 | 4 | 3 |
| RHH, RHW | 10 | 9 | 7 | 4 | 2 |

P1000, & -KO, P1100 & -KO

| Gauge | Number and Conductor Size (AWG) | | | | |
|------------|---------------------------------|----|----|----|----|
| | 14 | 12 | 10 | 8 | 6 |
| THWN, THHN | 88 | 66 | 42 | 20 | 14 |
| XHHW | 58 | 46 | 35 | 16 | 12 |
| T, TW | 57 | 44 | 34 | 16 | 9 |
| THW | 37 | 30 | 24 | 12 | 9 |
| RH | 33 | 27 | 16 | 9 | 6 |
| RHH, RHW | 23 | 20 | 16 | 9 | 6 |

| Channel Part Number | Channel Size and Inside Area | | | |
|------------------------|------------------------------|----------------|----------------|--------------|
| | Size | Area | 40% Area | 25% Area |
| P3300 & KO | 1 5/8" x 7/8" | 0.975 629 | 0.390 252 | 0.244 157 |
| P3000 & KO | 1 5/8" x 1 3/8" | 1.677 1,082 | 0.671 433 | 0.419 270 |
| P1000 & KO, P1100 & KO | 1 5/8" x 1 5/8" | 2.028 1,308 | 0.811 523 | 0.507 327 |
| P5500 & KO | 1 5/8" x 2 7/16" | 3.169 2,045 | 1.268 818 | 0.792 511 |
| P5000 & KO | 1 5/8" x 3 1/4" | 4.308 2,779 | 1.723 1,112 | 1.077 695 |

C.S.A. APPROVED

Suitable for number of wires in Column A when installed to support and supply electric discharge type lighting fixtures when raceway wiring is suitable for at least 75° C except wire suitable for 60° C may be used when clearance between fixtures and raceways is at least 1/2" (12.7). Also suitable for number of wires in column B when

P3000, & -KO

| Gauge | Number and Conductor Size (AWG) | | | | |
|------------|---------------------------------|----|----|----|----|
| | 14 | 12 | 10 | 8 | 6 |
| THWN, THHN | 72 | 54 | 34 | 17 | 12 |
| XHHW | 48 | 37 | 29 | 13 | 10 |
| T, TW | 46 | 36 | 28 | 13 | 7 |
| THW | 30 | 25 | 20 | 10 | 7 |
| RH | 27 | 22 | 13 | 7 | 5 |
| RHH, RHW | 19 | 16 | 13 | 7 | 5 |

P5500, & -KO

| Gauge | Number and Conductor Size (AWG) | | | | |
|------------|---------------------------------|-----|----|----|----|
| | 14 | 12 | 10 | 8 | 6 |
| THWN, THHN | 141 | 105 | 66 | 33 | 23 |
| XHHW | 93 | 73 | 57 | 27 | 19 |
| T, TW | 91 | 58 | 55 | 26 | 15 |
| THW | 59 | 49 | 39 | 20 | 15 |
| RH | 53 | 44 | 26 | 14 | 10 |
| RHH, RHW | 37 | 32 | 26 | 14 | 10 |

P5000, & -KO

| Gauge | Number and Conductor Size (AWG) | | | | |
|------------|---------------------------------|-----|----|----|----|
| | 14 | 12 | 10 | 8 | 6 |
| THWN, THHN | 193 | 105 | 91 | 45 | 32 |
| XHHW | 128 | 101 | 78 | 37 | 27 |
| T, TW | 125 | 98 | 75 | 35 | 20 |
| THW | 81 | 67 | 54 | 28 | 20 |
| RH | 73 | 60 | 36 | 19 | 13 |
| RHH, RHW | 51 | 44 | 36 | 19 | 13 |

Note:

Raceways with external joiners shall use a 40% wire fill calculation to determine the number of conductors permitted.

Raceways with internal joiners shall use a 25% wire fill calculation to determine the number of conductors permitted

Also UL Listed

P1001, P1101, P3001, P3301, P5001 & P5501

installed to support electric discharge type lighting fixtures when raceway wiring is suitable for at least 75° C and clearance between fixtures and raceway is at least 1/2" (3.2).

Maximum number of wires for types T, THN, THW, THWN, TW, R, RH, RHH, RHW or XHHW

| Raceway Wire Size AWG | P1000, &-KO P1100, &-KO | | P3000, &-KO | | P3300 | | P5000 &-KO | | P5500, &-KO | |
|-----------------------|----------------------------|----|-------------|----|-------|---|------------|----|-------------|----|
| | A | B | A | B | A | B | A | B | A | B |
| | 14 | 6 | 10 | 5 | 10 | 4 | 6 | 10 | 10 | 10 |
| 12 | 6 | 10 | 4 | 10 | 3 | 6 | 10 | 10 | 10 | 10 |
| 10 | 5 | 8 | 4 | 6 | - | - | 8 | 10 | 8 | 10 |
| 8 | 4 | 6 | 3 | 4 | - | - | 6 | 9 | 6 | 8 |
| 6 | 2 | 3 | 2 | 2 | - | - | 4 | 6 | 4 | 6 |

Unistrut channels are also certified by Canadian Standards Association.



FLUORESCENT FIXTURES - SUPPORT APPLICATIONS

Spring-Nut attachment system

Conduit connects through knockout in fixture. Fixture is supported by P1006-1420 spring nut and 1/4" round head machine screw. Assembly is supported by P2855 hinged hanger.

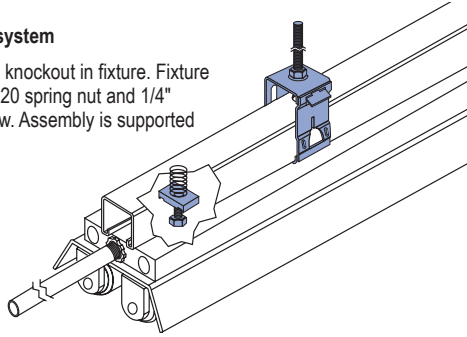

Slotted channel attachment system

Conduit connects through knockout in fixture. Fixture is supported by HCSS series hex bolt and hex nut. Raceway is supported by P2855 hanger. To splice a continuous run, use P3922.

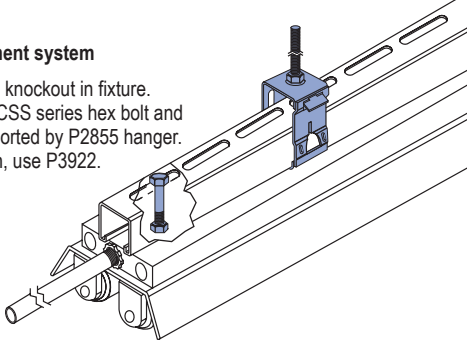

RECOMMENDED SUPPORT SPACING FOR FIXTURES

Deflections are based on continuity of span and use of 4 ft. fixtures weighing approximately 30 lbs. each. Do not use joiner fittings between supporting hangers. When using knock-out or slotted channels deflections will be increased approximately 5%. With fixtures spaced 2' - 0" apart, deflection is 60-70% of table. When spaced 4' - 0" apart, deflection is 50-60% of table.

Deflection Table

| Channel | Distance Between Supports - In (mm) | | | | | | | | |
|---------|-------------------------------------|--------------|---------------|---------------|---------------|---------------|---------------|---------------|---------------|
| | 8' (2.4m) | 10' (3m) | 12' (3.7m) | 14' (4.3m) | 16' (4.9m) | 18' (5.5m) | 20' (6.1m) | 22' (6.7m) | 24' (7.3m) |
| P3300 | 0.187 4.7 | - | - | - | - | - | - | - | - |
| P3000 | 0.100 | 0.250 6.4 | 0.500 12.7 | - | - | - | - | - | - |
| P1100 | 0.088 2.2 | 0.250 6.4 | 0.437 11.1 | 0.875 22.2 | - | - | - | - | - |
| P1000 | - | 0.180 4.6 | 0.312 7.9 | 0.625 15.9 | 1.000 25.4 | 1.625 41.3 | - | - | - |
| P5500 | - | - | - | 0.250 6.4 | 0.500 12.7 | 0.812 20.6 | 1.620 41.1 | - | - |
| P5000 | - | - | - | - | 0.310 7.9 | 0.625 15.9 | 1.000 25.4 | 1.800 45.7 | 2.500 63.5 |
| P1001 | - | - | - | - | 0.310 7.9 | 0.625 15.9 | 1.000 25.4 | 1.800 45.7 | 2.500 63.5 |
| P5001 | - | - | - | - | - | 0.200 5.1 | 0.250 6.4 | 0.400 10.2 | 0.500 12.7 |

HIGH-BAY FIXTURE RACEWAY APPLICATIONS

H.I.D. Knockout mounted system

Fixture attached to and wired from raceway by 1/2" nipple assembly of desired length at channel knockout. P1280W end cap, P3184 closure strip, P2535 conduit connector, and P2855 channel hanger complete assembly. For splicing channels into continuous raceway runs, use joiner fitting P3922.

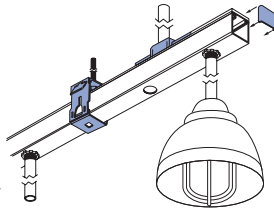

High-Bay dual mounted system

Fixtures are connected to and wired from raceway by conduit connector fitting P2536. Raceway is supported by P2855 hanger. P1280W end caps and P3184 closure strip complete the assembly. Conduit connected to raceway through channel knockout.

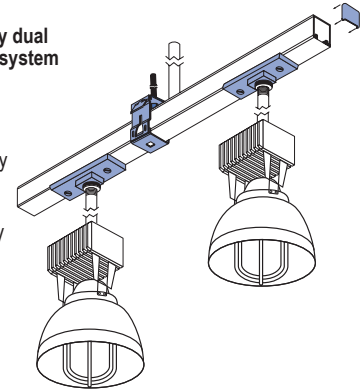

H.I.D. Plug-in system (with swivel)

Fixtures, supported by P2855 hangers and M2250 eyelets, plug into receptacle mounted in P2763 outlet box. P2855 hangers also support raceway. P2521-75 end connector joins conduit to raceway. P1280W end caps (not shown) and P3184 closure strip complete assembly.

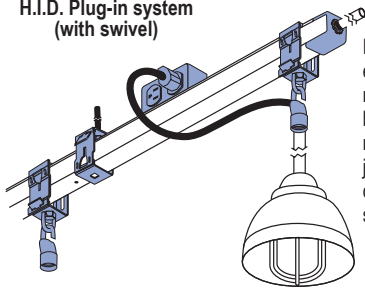

H.I.D. Plug-in system (rigid mount)

Fixtures are supported by P2602 clevis hangers. Cover plate on P2761 outlet box provides access to receptacle box. Raceway is supported and wired by top mounted P2535 conduit connectors. P1280W end caps and P3184 closure strip complete assembly.

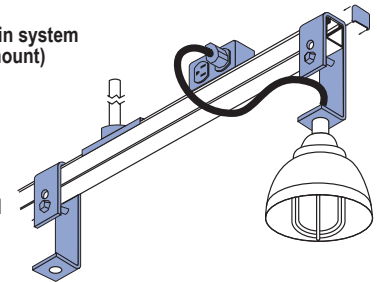

Uplighting with underhung or remote ballast

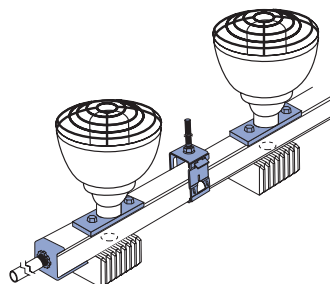

Fixtures attached to and wired from P2535 conduit fittings mounted to slot side of channel. Raceway can be wired by P2521 as shown or, conduit can enter through available knockout. Ballasts in P2521 are connected at the knockout by fixture adapter. In remote ballast installations, follow manufacturers instructions. P2855 hinged hangers support both types of installations. P3184 closure strip and P1280W end caps complete assembly. For continuous raceways, use joiner fitting P3922. P2521-75 end connector joins conduit to raceway.

15/16" Channel
Telesrnut System
Nuts & Hardware
General Fittings
Pipe/Conduit Supports
Electrical Fittings
Concrete Inserts
1 1/4" Framing System
1 1/4" Framing System
1 3/16" Framing System
Fiberglass System
Special Metals
PrimeAngle System
Product Index

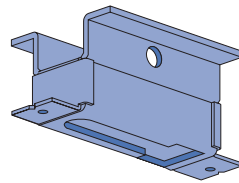
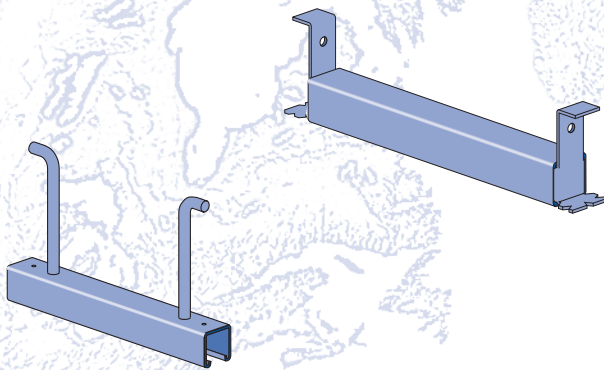
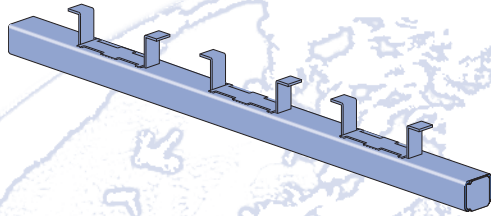

| | |
|----------------------------|----------|
| Heavy-Duty Inserts | 134-135 |
| Standard-Duty Inserts..... | 136, 138 |
| Light-Duty Inserts | 137 |
| Spot Inserts | 138 |
| Deck Inserts | 139 |
| Components | 139 |
| Technical Data | 140 |

MATERIAL

Cold-formed inserts are manufactured from standard 12 gauge (2.7 mm) Unistrut channel sections conforming to ASTM A1011 SS GR 33 or ASTM A653 GR 33, unless otherwise noted.

Hot-rolled inserts, as noted, are manufactured from carbon steel meeting physical requirements of ASTM A283 GR D.

To inhibit concrete seepage, all inserts (except spot inserts) are provided with closure strips and end caps or foam filler, unless otherwise requested.

Most concrete inserts are available in stainless steel on special order. Consult factory for ordering information.

APPLICATION

A wide range of heavy-duty to light-duty "continuous" and "spot" concrete inserts are available for use in pre-cast, pre-stressed or poured-in-place concrete floors, walls or ceilings.

FINISHES

Cold-formed, standard-duty, light-duty and spot concrete inserts are available in:

- Perma-Green III (GR),
- Hot dipped galvanized (HG), conforming to ASTM A123 or A153;
- Pre-galvanized (PG), conforming to ASTM A653 GR 33
- Plain (PL).

DESIGN LOAD

Design loads, where shown, are based on 3,000 PSI concrete, unless noted.

STANDARD LENGTHS

Insert lengths range from 3 inches (76 mm) to 20 feet (6.10m) with a tolerance of $\pm 1/4$ -inch (6.4mm).

DIMENSIONS

Imperial dimensions are illustrated in inches. Metric dimensions are shown in parentheses or as noted. Unless noted, all metric dimensions are in millimeters and rounded to one decimal place.

Custom-designed inserts are available on special order. Consult factory for ordering information.



Heavy Duty

Light Duty

Standard Duty

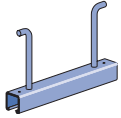

P3754-Pg 135

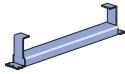

P3349-Pg 137

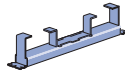

P3352-Pg 137

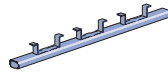

9P3354-Pg 137

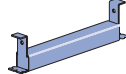

P3249-Pg 136

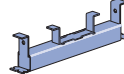

P3253-Pg 136

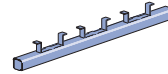

P3254-Pg 136

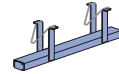

P3165-Pg 138



P2865-Pg 138

Spot Inserts and Components



P3245-Pg 138



P3245N4-Pg 138



M24-Pg 138



M2506-Pg 138

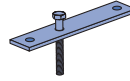

P3700-Pg 139

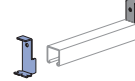

P1703-Pg 139



P2407-Pg 139

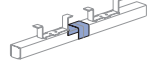

P3663-Pg 139

Fiberglass Concrete Inserts

Closure Strips

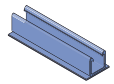

Heavy Duty-Pg 169

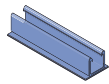

Standard Duty-Pg 171

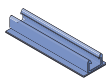

Light Duty-Pg 170



P1184
Pg 54



P1184P
Pg 54



P3184
Pg 54



P3184P
Pg 54



P3184F
Pg 54



P3712P
Pg 54

Channel Nuts



Heavy Duty-Pg 67



Heavy Duty-Pg 67



Standard Duty-Pg 67



Standard Duty-Pg 67



Light Duty-Pg 67



Light Duty-Pg 67

INSTALLING CONCRETE INSERTS

1. Nail insert to concrete form using prepunched nail holes
2. Attach rebars to flanges on insert

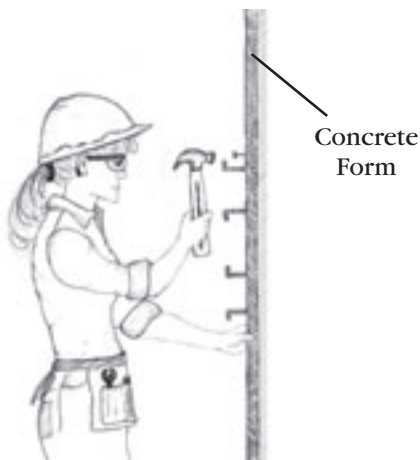

The Unistrut concrete insert is firmly fixed to the concrete side of the form before pouring. When the forms are removed, the insert is ready for use. Brackets and other components can be attached at any point of the continuous entry channel.

USING INSTALLED CONCRETE INSERT

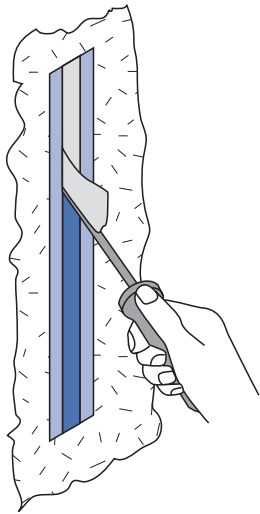

1. Scrape out filler

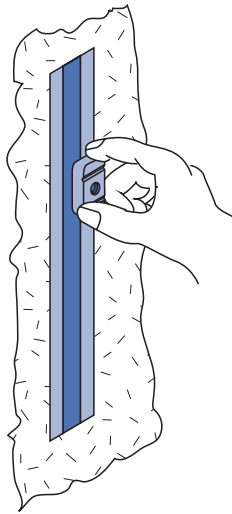

2. Insert channel nut.

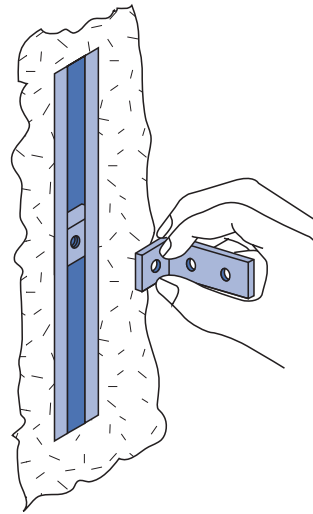

3. Attach fitting

P3754 SERIES

1 5/8" x 1 5/8" CHANNEL

- Closure strip P3712 P and a styrene bead end cap that fits inside the channel to inhibit concrete seepage are included.
- The recommended design load when used for curtain wall anchorage is 5,000 pounds and is based on use in average, good concrete. The design load includes 1/3 increase in load as permitted by AISI Specifications and Uniform Building Code when stresses are produced by wind or earthquake and other loads.
- The recommended design load is based on using two P1010 nuts at no less than 3" O.C. and no closer than 2" to either end of the insert. The distance between the insert centerline and the concrete edge must be a minimum of 3".
- All nuts and fittings for P3200 series concrete inserts will fit.
- Material: Cold formed from 12 Ga. (2.7mm) steel conforming to ASTM A1011 SS GR 33 or ASTM A653 GR 33 A. Stainless steel available on special order.
- Finish: Choice of Perma-Green II (GR), hot-dipped galvanized (HG) conforming to ASTM A123 or A153, pre-galvanized (PG) conforming to ASTM A653-G90, or plain (PL).

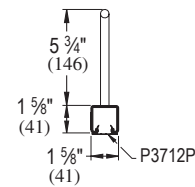
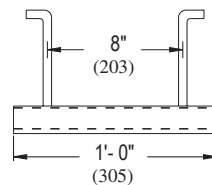
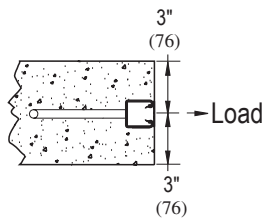
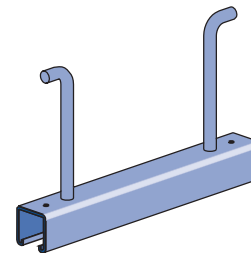

| Part Number | Insert Length ±1/4" (6.4mm) In (mm) | Wt/100 pcs Lbs (kg) | Max. Anchor Spacing In (mm) | Max. Allowable Point Load Lbs (kN) | Spacing of Point Loads In (mm) | Max. Allowable Uniform Load Lbs (kN) |
|-------------|---|---------------------------|--------------------------------|---------------------------------------|-----------------------------------|---|
| P3754 | 12 305 | 210 95.3 | 8 203 | 2,500 11.12 | 3 76 | 5,000 22.24 |

Safety factor 3



P3200 SERIES

1 5/8" x 1 3/8" CHANNEL

P3249 thru P3252

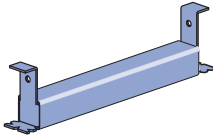

"NC" Suffix – No Closure Strip, With End Caps

"WC" Suffix – With Closure Strip & End Caps

P3253

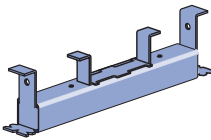

"NC" Suffix – No Closure Strip, With End Caps & Back Plates

"WC" Suffix – With Closure Strip, End Caps & Back Plates

P3254 thru P3270

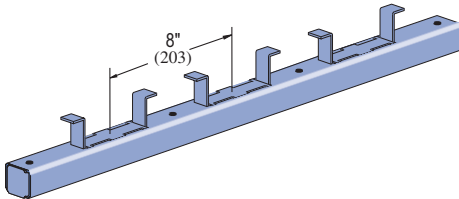

"NC" Suffix – No Closure Strip, W/End Caps & Back Plates

"WC" Suffix – W/Closure Strip, End Caps & Back Plates

"X" – No Closure Strip, No End Caps, W/Back Plates

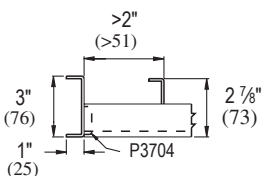
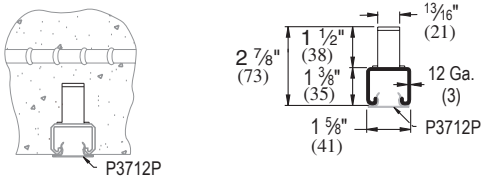

- Includes closure and end caps unless otherwise requested.
- P3280 end cap used when distance to first anchor is up to 2" (51 mm).
- P3704 end cap is used when end distance to first anchor is over 2" (51 mm).
- Nail or anchor inserts to forms every 16" (406 mm) to 24" (610 mm).
- Anchors are 8" (203 mm) on center.
- Material: Cold formed from 12 Ga. (3) steel conforming to ASTM A1011 SS GR 33 or ASTM A653 GR 33. A. Stainless steel available on special order.
- Finish: Choice of Perma-Green III (GR), hot-dipped galvanized (HG) conforming to ASTM A123 or A153, pre-galvanized (PG) conforming to ASTM A653-G90, or plain (PL).

| Part Number | Insert Length In/Ft (mm) | Wt/100 pcs Lbs (kg) | Max. Allowable Point Load Lbs (kN) | Min. Spacing of Pt. Loads In (mm) | Max. Allowable Uniform Load Lbs (kN) |
|-------------|-----------------------------|---------------------------|---|--|---|
| P3249 | 3" 76 | 85 39 | 500 2.2 | — | 500 2.22 |
| P3250 | 4" 102 | 100 45 | 800 3.6 | — | 800 3.56 |
| P3251 | 6" 152 | 130 59 | 1,000 4.5 | — | 1,000 4.45 |
| P3252 | 8" 203 | 159 72 | 1,200 5.3 | — | 1,200 5.34 |
| P3253 | 12" 305 | 227 103 | 2,000 8.9 | — | 2,000 8.90 |
| P3254 | 16" 406 | 270 123 | 2,000 8.9 | 12 305 | 4,000 17.79 |
| P3255 | 20" 508 | 357 162 | 2,000 8.9 | 12 305 | 4,000 17.79 |
| P3256 | 24" 610 | 399 181 | 2,000 8.9 | 12 305 | 4,000 17.79 |
| P3257 | 32" 813 | 527 239 | 2,000 8.9 | 12 305 | 2,000 2,976.3 (kg/m) |
| P3257A | 36" 914 | 616 279 | 2,000 8.9 | 12 305 | 2,000 2,976.3 (kg/m) |
| P3258 | 40" 1,016 | 661 300 | 2,000 8.9 | 12 305 | 2,000 2,976.3 (kg/m) |
| P3259 | 4' 1,219 | 786 357 | 2,000 8.9 | 12 305 | 2,000 2,976.3 (kg/m) |
| P3260 | 5' 1,524 | 1,003 455 | 2,000 8.9 | 12 305 | 2,000 2,976.3 (kg/m) |
| P3261 | 6' 1,829 | 1,173 532 | 2,000 8.9 | 12 305 | 2,000 2,976.3 (kg/m) |
| P3262 | 7' 2,134 | 1,390 631 | 2,000 8.9 | 12 305 | 2,000 2,976.3 (kg/m) |
| P3263 | 8' 2,438 | 1,560 708 | 2,000 8.9 | 12 305 | 2,000 2,976.3 (kg/m) |
| P3264 | 9' 2,743 | 1,741 790 | 2,000 8.9 | 12 305 | 2,000 2,976.3 (kg/m) |
| P3265 | 10' 3,048 | 1,947 883 | 2,000 8.9 | 12 305 | 2,000 2,976.3 (kg/m) |
| P3266 | 12' 3,658 | 2,334 1,059 | 2,000 8.9 | 12 305 | 2,000 2,976.3 (kg/m) |
| P3267 | 14' 4,267 | 2,717 1,232 | 2,000 8.9 | 12 305 | 2,000 2,976.3 (kg/m) |
| P3268 | 16' 4,877 | 3,116 1,413 | 2,000 8.9 | 12 305 | 2,000 2,976.3 (kg/m) |
| P3269 | 18' 5,486 | 3,530 1,601 | 2,000 8.9 | 12 305 | 2,000 2,976.3 (kg/m) |
| P3270 | 20' 6,096 | 3,882 1,761 | 2,000 8.9 | 12 305 | 2,000 2,976.3 (kg/m) |

Safety factor 3.

1 5/8" Channel
 Telesstrut System
 Nuts & Hardware
 General Fittings
 Pipe/Conduit Supports
 Electrical Fittings
 Concrete Inserts
 1 1/4" Framing System
 1 3/8" Framing System
 Fiberglass System
 Special Metals
 PrimeAngle System
 Product Index

P3300 SERIES

1 5/8" x 7/8" CHANNEL

P3349 thru P3351



(When used for sprinkler systems only.)

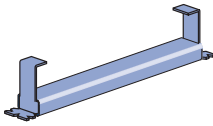

"NC" Suffix – No Closure Strip, With End Caps
 "WC" Suffix – With Closure Strip & End Caps

P3352 thru P3353

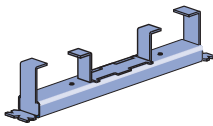

"NC" Suffix – No Closure Strip, With End Caps & Back Plates
 "WC" Suffix – With Closure Strip, End Caps & Back Plates

P3354 thru P3370

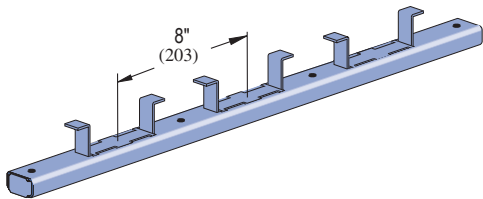

"NC" Suffix – No Closure Strip, W/End Caps & Back Plates
 "WC" Suffix – W/Closure Strip, End Caps & Back Plates
 "X" – No Closure Strip, No End Caps, W/Back Plates

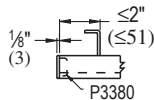
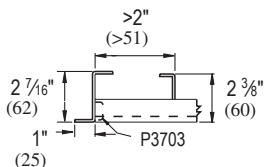
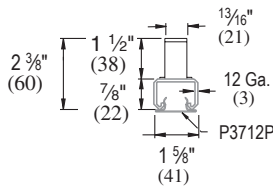
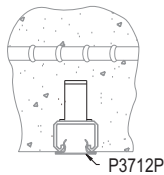

- Includes closure and end caps unless otherwise requested.
- P3380 end cap used when distance to first anchor is up to 2" (51 mm).
- P3703 end cap is used when end distance to first anchor is over 2" (51 mm).
- Nail or anchor inserts to forms every 16" (406 mm) to 24" (610 mm).
- Anchors are 8" (203 mm) on center.
- Material: Cold formed from 12 Ga. (3 mm) steel conforming to ASTM A1011 SS GR. 33 or A653 GR 33. A. Stainless steel available on special order.
- Finish: Choice of Perma-Green III (GR), hot-dipped galvanized (HG) conforming to ASTM A123 or A153, pre-galvanized (PG) conforming to ASTM A653-G90, or plain (PL).

| Part Number | Insert Length In/Ft. (mm) | Wt/100 pcs Lbs (kg) | Max. Allowable Point Load Lbs (kN) | Min. Spacing of Pt. Loads In (mm) | Max. Allowable Uniform Load Lbs (kN) |
|-------------|------------------------------|------------------------|---------------------------------------|--------------------------------------|---|
| P3349 | 3" 76 | 68 31 | 400 1.8 | — | 400 1.78 |
| P3350 | 4" 102 | 81 37 | 500 2.2 | — | 500 2.22 |
| P3351 | 6" 152 | 102 46 | 750 3.3 | — | 750 3.34 |
| P3352 | 8" 203 | 122 55 | 1,000 4.5 | — | 1,000 4.45 |
| P3353 | 12" 305 | 174 79 | 1,500 6.7 | — | 1,500 6.67 |
| P3354 | 16" 406 | 185.0 84 | 1,500 6.7 | 12 305 | 3,000 13.34 |
| P3355 | 20" 508 | 231 105 | 1,500 6.7 | 12 305 | 3,000 13.34 |
| P3356 | 24" 610 | 277 126 | 1,500 6.7 | 12 305 | 3,000 13.34 |
| P3357 | 32" 813 | 370 168 | 1,500 6.7 | 12 305 | 1,500 Lbs./Ft. 2,232.2 (kg/m) |
| P3357A | 36" 914 | 416 189 | 1,500 6.7 | 12 305 | 1,500 Lbs./Ft. 2,232.2 (kg/m) |
| P3358 | 40" 1,016 | 463 210 | 1,500 6.7 | 12 305 | 1,500 Lbs./Ft. 2,232.2 (kg/m) |
| P3359 | 4' 1,219 | 555 252 | 1,500 6.7 | 12 305 | 1,500 Lbs./Ft. 2,232.2 (kg/m) |
| P3360 | 5' 1,524 | 694 315 | 1,500 6.7 | 12 305 | 1,500 Lbs./Ft. 2,232.2 (kg/m) |
| P3361 | 6' 1,829 | 832 377 | 1,500 6.7 | 12 305 | 1,500 Lbs./Ft. 2,232.2 (kg/m) |
| P3362 | 7' 2,134 | 971 440 | 1,500 6.7 | 12 305 | 1,500 Lbs./Ft. 2,232.2 (kg/m) |
| P3363 | 8' 2,438 | 1,110 504 | 1,500 6.7 | 12 305 | 1,500 Lbs./Ft. 2,232.2 (kg/m) |
| P3364 | 9' 2,743 | 1,249 567 | 1,500 6.7 | 12 305 | 1,500 Lbs./Ft. 2,232.2 (kg/m) |
| P3365 | 10' 3,048 | 1,387 629 | 1,500 6.7 | 12 305 | 1,500 Lbs./Ft. 2,232.2 (kg/m) |
| P3366 | 12' 3,658 | 1,665.0 755 | 1,500 6.7 | 12 305 | 1,500 Lbs./Ft. 2,232.2 (kg/m) |
| P3367 | 14' 4,267 | 1,942 881 | 1,500 6.7 | 12 305 | 1,500 Lbs./Ft. 2,232.2 (kg/m) |
| P3368 | 16' 4,877 | 2,220 1,007 | 1,500 6.7 | 12 305 | 1,500 Lbs./Ft. 2,232.2 (kg/m) |
| P3369 | 18' 5,486 | 2,497 1,133 | 1,500 6.7 | 12 305 | 1,500 Lbs./Ft. 2,232.2 (kg/m) |
| P3370 | 20' 6,096 | 2,775 1,259 | 1,500 6.7 | 12 305 | 1,500 Lbs./Ft. 2,232.2 (kg/m) |

Safety factor 3.



P3165 SERIES

1 5/8" x 7/8" CHANNEL

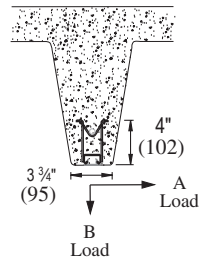
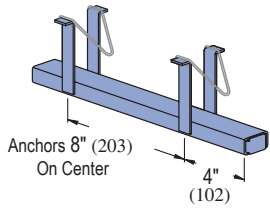

"X" Suffix – No Closure Strip, No End Caps
 "WC" Suffix – With Closure Strip & End Caps

Maximum allowable load/ft.

| Part No. | Length Ft (M) | Wt/100 pcs Lbs (kg) |
|----------|---------------|---------------------|
| P3165 | 10 3.05 | 1,650 748.4 |
| P3170 | 20 6.10 | 3,280 1,487.8 |

| Concrete | A Lbs (kN) | B Lbs (kN) |
|-----------|------------|--------------|
| Light Wt | 425 1.9 | 800 3.6 |
| Normal Wt | 500 2.2 | 1,000 4.5 |

Safety factor 3.

Safety factor 3.

- Designed for use in prestressed concrete.
- Anchors 8" (203 mm) on center; first anchor 4" (102 mm) from end.
- Includes closure and end caps unless otherwise requested.
- Material: Cold formed from 12 Ga. (2.7 mm) steel conforming to ASTM A1011 SS GR 33 or ASTM A653 GR 33. A. Stainless steel available on special order.
- Finish: Choice of Perma-Green II (GR), hot-dipped galvanized (HG) conforming to ASTM A123 or A153, pre-galvanized (PG) conforming to ASTM A653-G90, or plain (PL).

P2865-10, -15, -20

HOLD-DOWN SPRINGS

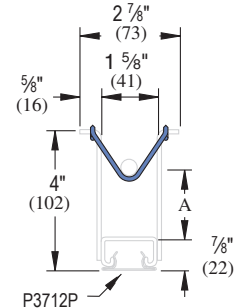
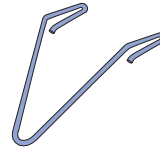

Finish: Plain

| Part Number | A In (mm) | Wt/100 pcs Lbs (kg) |
|-------------|-------------|---------------------|
| P2865-10 | 1 25 | 2 0.9 |
| P2865-15 | 1 1/2 38 | 2 0.9 |
| P2865-20 | 2 51 | 2 0.9 |

P3245

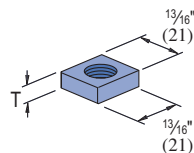
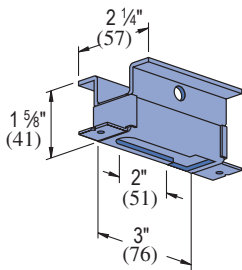

Square Nut for P3245 Insert

| Part Number | Wt/100 pcs Lbs (kg) | Max. Allowable Pt. Load Lbs (kN) |
|-------------|---------------------|----------------------------------|
| P3245 | 54 24.5 | 1,000 4.45 |

| Part Number | Size/Thread In | T In (mm) | Wt/100 pcs Lbs (kg) |
|-------------|----------------|-------------|---------------------|
| P3245-N4 | 1/4" — 20 | 5/16" 8 | 6 2.7 |
| P3245-N6 | 3/8" — 16 | 5/16" 8 | 5 2.3 |
| HSQN050 | 1/2" — 13 | 7/16" 11 | 6 2.7 |

Finish: Pre-galvanized

Safety factor of 3

- For 1/4", 3/8", or 1/2" size attachment or hanger rod.
- Insert nuts to be ordered separately.

M24

SPOT INSERT

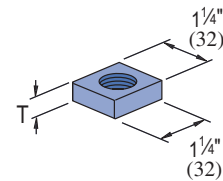
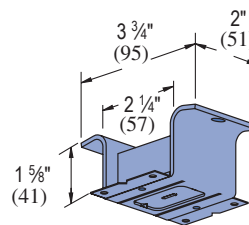

Square Nut for M24

| Part Number | Wt/100 pcs Lbs (kg) | Max. Allowable Pt. Load Lbs (kN) |
|-------------|---------------------|----------------------------------|
| M24 | 52 23.6 | 800 3.56 |

| Part Number | Size/Thread In | T In (mm) | Wt/100 pcs Lbs (kg) |
|-------------|----------------|------------|---------------------|
| M2506 | 1/4" — 20 | 1/4" 6 | 13 5.9 |
| M2508 | 3/8" — 16 | 3/8" 9 | 14 6.4 |
| M2510 | 1/2" — 13 | 1/2" 13 | 14 6.4 |
| M2512 | 5/8" — 11 | 1/2" 13 | 12 5.4 |
| M2523 | 3/4" — 10 | 1/2" 13 | 11 5.0 |
| M2524 | 7/8" — 9 | 1/2" 13 | 10 4.5 |

Finish: Electro-galvanized

Safety factor of 5

- Ribs along sides of slot give extra strength to case.
- Insert nuts M2506 thru M2524 to be ordered separately.

15/8" Channel
 Telesruct System
 Nuts & Hardware
 General Fittings
 Pipe/Conduit Supports
 Electrical Fittings
 Concrete Inserts
 1 1/4" Framing System
 1 3/16" Framing System
 Fiberglass System
 Special Metals
 PrimeAngle System
 Product Index

P3700 SERIES

DECK INSERT

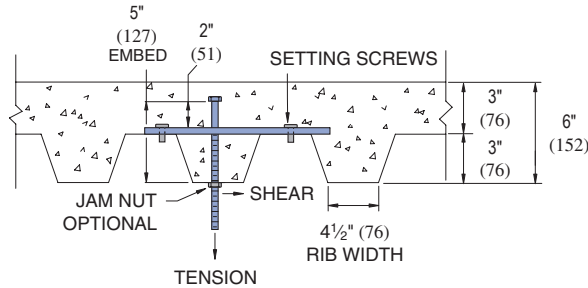
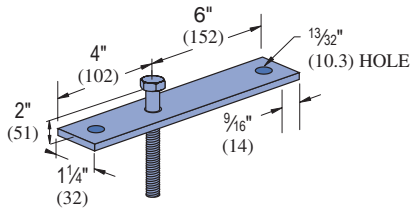

| Part Number | Rod Dia. In | Tension Load Lbs (kN) | Shear Load Lbs (kN) | Wt/100 pcs Lbs (kg) |
|-------------|-------------|-----------------------|---------------------|---------------------|
| P3700-37 | 3/8 | 850 3.8 | 600 2.7 | 89 40.4 |
| P3700-50 | 1/2 | 1380 6.1 | 1000 4.5 | 111 50.3 |
| P3700-62 | 5/8 | 1920 8.5 | 1760 7.8 | 141 64.0 |

Notes:

1. Allowable loads have been determined by the manufacturer's testing, analysis, and technical specification.
2. Values are based on a safety factor of 5.
3. 20 Gauge Metal Deck

P1703, P1704, P3704, P3703

END CAP ANCHORS

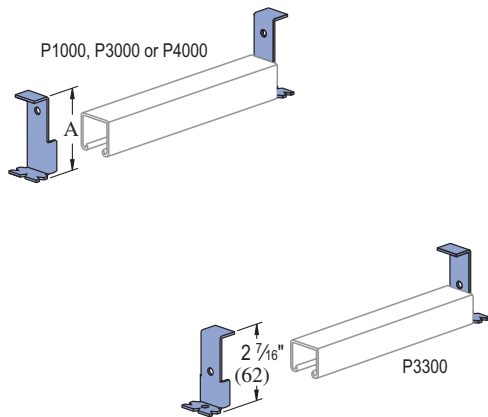

| Part Number | Channel | "A" In (mm) | Wt/100 pcs Lbs (kg) |
|-------------|---------|-------------|---------------------|
| P1703 | P1000 | 2 13/32 | 30 |
| | | 61 | 13.6 |
| P1704 | P1000 | 3 17/32 | 37 |
| P3703 | P3300 | 90 | 16.8 |
| | | 2 7/16 | 17 |
| P3704 | P3000 | 62 | 7.7 |
| | | 3 | 20 |
| P4703 | P4000 | 76 | 9.1 |
| | | 2 3/8 | 27 |
| | | 60 | 12.2 |

Note: End cap anchor for use with 1 5/8" wide standard Unistrut inserts only.

P2407, P3280, P3380

END CAPS

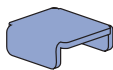

| Part Number | Fits Channel | Wt/100 pcs Lbs (kg) |
|-------------|--------------|---------------------|
| P2407 | P1000 | 10 4.5 |
| P3280 | P3000 | 8 3.6 |
| P3380 | P3300 | 5 2.3 |

P3663, P4663

JOINT COVERS

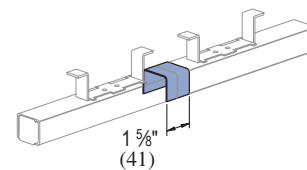

| Part Number | Use With Insert Series | Wt/100 pcs Lbs (kg) |
|-------------|------------------------|---------------------|
| P3663 | P3270 | 10 4.5 |
| P4663 | P3370 | 6 2.7 |

NOTE: Joint cover for use with 1 5/8" wide standard Unistrut inserts only.

Note

When used for mechanical supports, load capacities of brackets and fittings should be in compliance with the American Standard Code for Pressure Piping.

1 5/8" Channel
 Telestrut System
 Nuts & Hardware
 General Fittings
 Pipe/Conduit Supports
 Electrical Fittings
 Concrete Inserts
 1 1/2" Framing System
 1 3/4" Framing System
 Fiberglass System
 Special Metals
 PrimeAngle System
 Product Index



LOAD CHART BY LENGTH

| Part Number | Insert Length In (mm) | Wt/100 ft Lbs (kg) | Anchor Spacing In (mm) | Max. Allowable Point Load Lbs (kN) | Min. Spacing Between Pt. Loads In (mm) | Max. Allowable Uniform Load Lbs (kN) |
|-------------|-----------------------|--------------------|------------------------|------------------------------------|--|--------------------------------------|
| P3249 | 3 | 85 | 3 | 500 | - | 500 |
| | | 38.6 | 76 | 2.22 | - | 2.22 |
| P3349 | 76 | 68 | 3 | 400 | - | 400 |
| | | 30.8 | 76 | 1.78 | - | 1.78 |
| P3250 | 4 | 100 | 4 | 800 | - | 800 |
| | | 45.4 | 102 | 3.56 | - | 3.56 |
| P3350 | 102 | 81 | 4 | 500 | - | 500 |
| | | 36.7 | 102 | 2.22 | - | 2.22 |
| P3251 | 6 | 130 | 6 | 1,000 | - | 1,000 |
| | | 59.0 | 152 | 4.45 | - | 4.45 |
| P3351 | 152 | 102 | 6 | 750 | - | 750 |
| | | 46.3 | 152 | 3.34 | - | 3.34 |
| P3252 | 8 | 159 | 8 | 1,200 | - | 1,200 |
| | | 72.1 | 203 | 5.34 | - | 5.34 |
| P3352 | 203 | 122 | 8 | 1,000 | - | 1,000 |
| | | 55.3 | 203 | 4.45 | - | 4.45 |
| P3754 | 12 | 210 | 8 | 2,500 | 3 | 5,000 |
| | | 95.3 | 203 | 11.12 | 76 | 22.24 |
| P3253 | 305 | 227 | 4 | 2,000 | - | 2,000 |
| | | 103.0 | 102 | 8.90 | - | 8.90 |
| P3353 | 406 | 174 | 4 | 1,500 | - | 1,500 |
| | | 78.9 | 102 | 6.67 | - | 6.67 |
| P3254 | 16 | 270 | 4 | 2,000 | 12 | 4,000 |
| | | 122.5 | 102 | 8.90 | 305 | 17.79 |
| P3354 | 406 | 185 | 4 | 1,500 | 12 | 3,000 |
| | | 83.9 | 102 | 6.67 | 305 | 13.3 |
| P3255 | 20 | 357 | 4 | 2,000 | 12 | 4,000 |
| | | 161.9 | 102 | 8.90 | 305 | 17.79 |
| P3355 | 508 | 231 | 4 | 1,500 | 12 | 3,000 |
| | | 104.8 | 102 | 6.67 | 305 | 13.34 |
| P3256 | 24 | 399 | 4 | 2,000 | 12 | 4,000 |
| | | 181.0 | 102 | 8.90 | 305 | 17.79 |
| P3356 | 610 | 277 | 4 | 1,500 | 12 | 3,000 |
| | | 125.6 | 102 | 6.67 | 305 | 13.34 |

SPOT INSERT LOAD CHART

| Part Number | Wt/100 pcs Lbs (kg) | Anchor Spacing In (mm) | Max. Allowable Point Load Lbs (kN) | Min. Spacing Between Pt. Loads In (mm) | Max. Allowable Uniform Load Lbs/Ft (kg/m) |
|-------------|---------------------|------------------------|------------------------------------|--|---|
| M26/M2812 | 54 | - | 1,500 | - | 1,500 |
| | 24.5 | - | 6.67 | - | 680.4 |
| M3245 | 52 | - | 1,000 | - | 1,000 |
| | 23.6 | - | 4.45 | - | 453.6 |
| M24/M2512 | 52 | - | 800 | - | 800 |
| | 23.6 | - | 3.56 | - | 362.9 |

MAXIMUM ALLOWABLE POINT LOAD

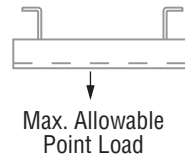

The maximum allowable point load may be placed anywhere along the insert. All loads placed less than 2" from the end of an insert must be reduced by 50%.

MAXIMUM ALLOWABLE UNIFORM LOAD

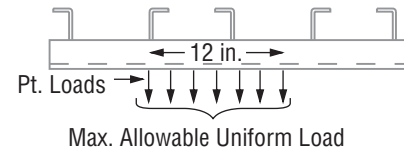

The maximum allowable uniform load must be placed as a series of point loads.

SPACING OF MULTIPLE POINT LOADS

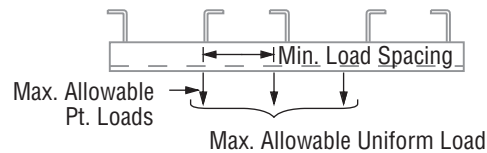

CONTINUOUS CONCRETE INSERT LOAD CHART

Up to 20 Ft. (6.10m)

| Part Number | Wt/100 ft Lbs (kg) | Anchor Spacing In (mm) | Max. Allowable Point Load Lbs (kN) | Min. Spacing Between Pt. Loads In (mm) | Max. Allowable Uniform Load Lbs/Ft (kg/m) |
|-------------|--------------------|------------------------|------------------------------------|--|---|
| P3270 | 194 | 4 | 2,000 | 12 | 2,000 |
| | 88.0 | 102 | 8.90 | 305 | 2,976.3 |
| P3370 | 139 | 4 | 1,500 | 12 | 1,500 |
| | 63.0 | 102 | 6.67 | 305 | 2,232.2 |
| P3170* | 165 | 8 | 1,000 | 12 | 1,000 |
| | 74.8 | 203 | 4.45 | 305 | 1,488.2 |

*When used in prestressed concrete "T" Beam.
Load data is based on use of 3000 PSI concrete.

PULL-OUT LOAD

Minimum Edge Distance to Achieve Rated Pull-Out Capacity

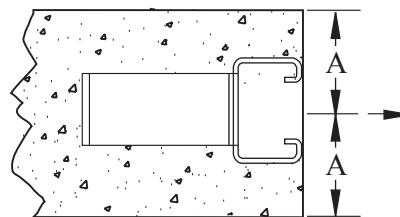



1 1/4" FRAMING SYSTEM

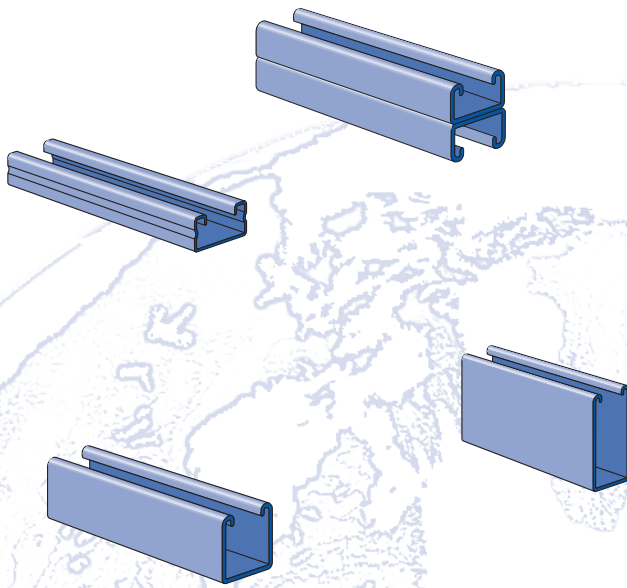

| | |
|---------------------------------------|---------|
| A1000 (14 Gauge) | 143-144 |
| A3300 (14 Gauge) | 145-146 |
| A4000 (19 Gauge) | 147-148 |
| A5000 (14 Gauge) | 149 |
| Channel Nuts and Closure Strips | 150-151 |
| Flat Plate Fittings | 151 |
| Ninety Degree Fittings..... | 151-152 |
| "Z" Shape Fittings | 152 |
| Angle and Wing Shape Fittings | 153 |
| "U" Shape Fittings | 153 |
| Tubing Clips | 154 |
| Brackets | 154 |

MATERIAL

Unistrut channels are accurately and carefully cold formed to size from low-carbon strip steel.

STEEL: PLAIN

- 14 Gauge (1.9 mm), ASTM A1011 SS GR 33
- 19 Gauge (1.0 mm) ASTM A1008

STEEL: PRE-GALVANIZED

- 14 Gauge (1.9 mm) ASTM A653 GR 33,
- 19 Gauge (1.0 mm) ASTM A653 GR 33

Channel nuts are manufactured from mild steel bars conforming to ASTM A576, GR 1015, and are case hardened.

Fittings are made from hot rolled, pickled and oiled steel plate or strip and conform to ASTM A1011 SS GR 33.

Many framing channels are available in special metal on request. Consult factory for ordering information.

FINISHES

All channels and fittings are available in: Perma-Green III (GR), Pre-galvanized (PG), conforming to ASTM A653 GR 33 and plain (PL).

Nuts are available in plain or electro-galvanized (EG) finish.

Fittings are available in Perma-Green III (GR) or plain (PL).

STANDARD LENGTHS

Standard lengths are 10 feet (3.05M) and 20 feet (6.10M). Tolerances are: +1/8" (3.2 mm) to +1/2" (12.7 mm) to allow for cutting. Special lengths are available for a small cutting charge with a tolerance of ±1/8" (3.2mm).

APPLICATION

A framing system designed for medium loads, the 1 1/4" series is especially suitable for use in the OEM, commercial and display markets. It maintains a lightness in scale and a clean line that makes it aesthetically pleasing as well as functional.

THREADS

All threads on the nuts and bolts are Unified and American coarse screw threads.

DESIGN BOLT TORQUE

| BOLT SIZE | 1/4"-20 | 5/16"-18 | 3/8"-16 |
|--------------|---------|----------|---------|
| Rec. Torque | 6 | 11 | 19 |
| Ft/Lbs (N•m) | (8) | (15) | (26) |
| Max Torque | 7 | 15 | 25 |
| Ft/Lbs (N•m) | (9) | (20) | (34) |

DIMENSIONS

Imperial dimensions are illustrated in inches. Metric dimensions are shown in parenthesis or as noted. Unless noted, all metric dimensions are in millimeters and rounded to one decimal place.

LOAD DATA

All beam and column load data pertains to carbon steel and stainless steel channels. Load tables and charts are constructed to be in accordance with the SPECIFICATION FOR THE DESIGN OF COLD-FORMED STEEL STRUCTURAL MEMBERS 2001 EDITION published by the AMERICAN IRON AND STEEL INSTITUTE USING ASD METHOD.



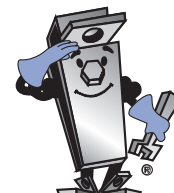

| Type of Load | Safety Factor to Yield Strength | Safety Factor to Ultimate Strength |
|--------------|---------------------------------|------------------------------------|
| Beam Loads | 1.67 | 2.0 |
| Column Load | 1.80 | 2.2 |



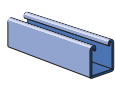
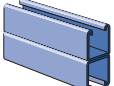
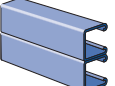
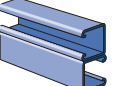
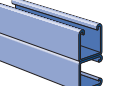
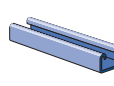
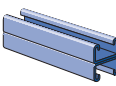

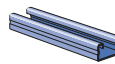
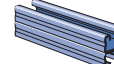







1 5/8" Channel
 Teleslitrut System
 Nuts & Hardware
 General Fittings
 Pipe/Conduit Supports
 Electrical Fittings
 Concrete Inserts
 1 1/4" Framing System
 1 3/16" Framing System
 Fiberglass System
 Special Metals
 PrimeAngle System
 Product Index

| | |
|---|--|
| <p>A1000 Series</p> <p>1 1/4" x 1 1/4" 14 Ga.</p>  <p>A1000-Pg 143</p>  <p>A1001-Pg 143</p>  <p>A1001 A-Pg 144</p>  <p>A1001 B-Pg 144</p>  <p>A1001 C-Pg 144</p> | <p>A3300 Series</p> <p>1 1/4" x 3/4" 14 Ga.</p>  <p>A3300-Pg 145</p>  <p>A3301-Pg 145</p> |
|---|--|

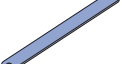

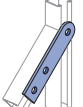



| | | |
|--|--|--|
| <p>A4000 Series</p> <p>1 1/4" x 5/8" 19 Ga.</p>  <p>A4000-Pg 147</p>  <p>A4001-Pg 147</p> | <p>A5000 Series</p> <p>1 1/4" x 2 1/2" 14 Ga.</p>  <p>A5000-Pg 149</p> | <p>Channel Nuts & Closures</p>  <p>A1006-1420-Pg 150</p>  <p>A4006-1420-Pg 150</p>  <p>A5506-1420-Pg 150</p> |
|--|--|--|

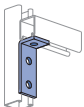
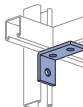
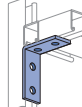
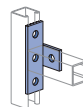
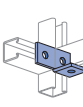
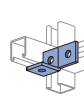
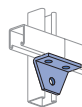
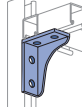
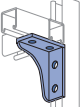

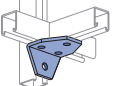
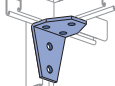

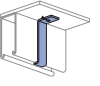
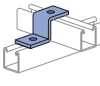



| | | | | | | |
|--|--|---|---|--|---|--|
|  A3006-1420-Pg 150 |  A3016-0832-Pg 150 |  A1280-Pg 151 |  A4280-Pg 151 |  A5280-Pg 151 |  A1184-Pg 151 |  A1184P-Pg 151 |
|--|--|---|---|--|---|--|





A Series Fittings

| | | | | | | | | |
|---|---|--|---|---|---|---|---|---|
|  A1063-Pg 151 |  A1065-Pg 151 |  A1191-Pg Pg 151 |  A1066-Pg 151 |  A2324-Pg 151 |  A1036-Pg 151 |  A1031-Pg 151 |  A1026-Pg 151 |  A1068-Pg 151 |
|---|---|--|---|---|---|---|---|---|

| | | | | | | | | |
|---|---|---|---|---|---|---|---|---|
|  A1326-Pg 151 |  A1458-Pg 151 |  A1325-Pg 152 |  A1033-Pg 152 |  A1037-Pg 152 |  A1038-Pg 152 |  A1357-Pg 152 |  A1331-Pg 152 |  A1332-Pg 152 |
|---|---|---|---|---|---|---|---|---|

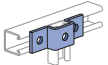
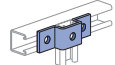
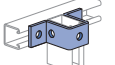
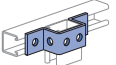
| | | | | | | | | |
|---|---|---|---|---|---|---|---|---|
|  A1579-Pg 152 |  A2235-Pg 152 |  A2120-Pg 152 |  A4120-Pg 152 |  A5120-Pg 152 |  A1045-Pg 152 |  A3345-Pg 152 |  A4045-Pg 152 |  A5045-Pg 152 |
|---|---|---|---|---|---|---|---|---|

| | | | | | | | | |
|---|---|---|---|---|---|---|---|---|
|  A2109-Pg 153 |  A2125-Pg 153 |  A2084-Pg 153 |  A2341 R-L-Pg 153 |  A2472 R-L-Pg 153 |  A2223-Pg 153 |  A2345-Pg 153 |  A2227-Pg 153 |  A1047-Pg 153 |
|---|---|---|---|---|---|---|---|---|

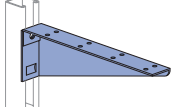
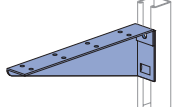
| | | | | | | | | |
|---|---|---|---|---|---|--|---|---|
|  A3347-Pg 153 |  A4047-Pg 153 |  A5047-Pg 153 |  A5043-Pg 153 |  A2608-Pg 154 |  A2491 R-Pg 154 |  A2491 L-Pg 154 |  A2494 R-Pg 154 |  A2494 L-Pg 154 |
|---|---|---|---|---|---|--|---|---|

A1000 – 1 1/4" x 1 1/4"

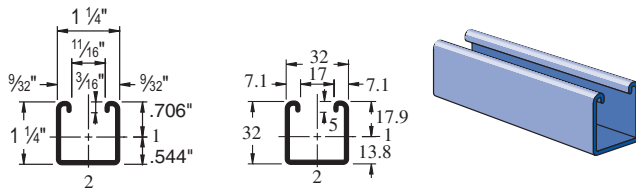

Wt/100 Ft: 104 Lbs(154 kg/100m)
 Allowable Moment 2,170 In-Lbs (240 N•m)
 14 Gauge Nominal Thickness .075" (1.9mm)

A1001 – 1 1/4" x 2 1/2"

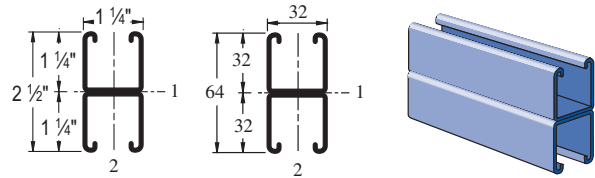

Wt/100 Ft: 207 Lbs (308 kg/100m)
 Allowable Moment 6,070 In-Lbs (690 N•m)
 14 Gauge Nominal Thickness .075" (1.9mm)

A1000 - BEAM LOADING

| Span In | Max Allowable Uniform Load Lbs | Defl. at Uniform Load In | Uniform Loading at Defl. | | |
|---------|--------------------------------|--------------------------|--------------------------|--------------|--------------|
| | | | Span/180 Lbs | Span/240 Lbs | Span/360 Lbs |
| 18 | 960 | 0.04 | 960 | 960 | 960 |
| 24 | 720 | 0.07 | 720 | 720 | 660 |
| 36 | 480 | 0.16 | 480 | 440 | 300 |
| 48 | 360 | 0.29 | 330 | 250 | 170 |
| 60 | 290 | 0.45 | 210 | 160 | 110 |
| 72 | 240 | 0.65 | 150 | 110 | 70 |
| 84 | 210 | 0.90 | 110 | 80 | 50 |
| 96 | 180 | 1.16 | 80 | 60 | 40 |
| 108 | 160 | 1.46 | 70 | 50 | 30 |
| 120 | 140 | 1.75 | 50 | 40 | 30 |

A1001 - BEAM LOADING

| Span In | Max Allowable Uniform Load Lbs | Defl. at Uniform Load In | Uniform Loading at Defl. | | |
|---------|--------------------------------|--------------------------|--------------------------|--------------|--------------|
| | | | Span/180 Lbs | Span/240 Lbs | Span/360 Lbs |
| 18 | 1,650* | 0.01 | 1,650* | 1,650* | 1,650* |
| 24 | 1,650* | 0.03 | 1,650* | 1,650* | 1,650* |
| 36 | 1,350 | 0.09 | 1,350 | 1,350 | 1,350 |
| 48 | 1,010 | 0.16 | 1,010 | 1,010 | 820 |
| 60 | 810 | 0.26 | 810 | 790 | 530 |
| 72 | 670 | 0.37 | 670 | 550 | 370 |
| 84 | 580 | 0.50 | 540 | 400 | 270 |
| 96 | 510 | 0.66 | 410 | 310 | 210 |
| 108 | 450 | 0.83 | 330 | 240 | 160 |
| 120 | 400 | 1.01 | 260 | 200 | 130 |

A1000 - COLUMN LOADING

| Unbraced Height In | Maximum Allowable Load at Slot Face Lbs | Maximum Column Load Applied at C.G. | | | |
|--------------------|---|-------------------------------------|--------------|-------------|-------------|
| | | K = 0.65 Lbs | K = 0.80 Lbs | K = 1.0 Lbs | K = 1.2 Lbs |
| 18 | 1,960 | 5,900 | 5,430 | 4,800 | 4,210 |
| 24 | 1,840 | 5,210 | 4,590 | 3,850 | 3,220 |
| 36 | 1,500 | 3,940 | 3,220 | 2,480 | 2,010 |
| 48 | 1,220 | 2,950 | 2,300 | 1,790 | 1,460 |
| 60 | 1,020 | 2,260 | 1,790 | 1,400 | 1,130 |
| 72 | 880 | 1,840 | 1,460 | 1,130 | 910 |
| 84 | 780 | 1,550 | 1,230 | 940 | ** |
| 96 | 690 | 1,340 | 1,050 | ** | ** |
| 108 | 620 | 1,170 | 910 | ** | ** |

A1001 - COLUMN LOADING

| Unbraced Height In | Maximum Allowable Load at Slot Face Lbs | Maximum Column Load Applied at C.G. | | | |
|--------------------|---|-------------------------------------|--------------|-------------|-------------|
| | | K = 0.65 Lbs | K = 0.80 Lbs | K = 1.0 Lbs | K = 1.2 Lbs |
| 18 | 3,530 | 13,300 | 12,920 | 12,400 | 11,880 |
| 24 | 3,480 | 12,750 | 12,220 | 11,550 | 10,950 |
| 36 | 3,370 | 11,630 | 10,950 | 10,220 | 9,150 |
| 48 | 3,260 | 10,680 | 10,020 | 8,260 | 6,500 |
| 60 | 2,960 | 9,930 | 8,260 | 6,080 | 4,270 |
| 72 | 2,630 | 8,480 | 6,500 | 4,270 | 2,970 |
| 84 | 2,260 | 7,040 | 4,900 | 3,140 | 2,180 |
| 96 | 1,940 | 5,680 | 3,750 | 2,400 | ** |
| 108 | 1,670 | 4,490 | 2,970 | ** | ** |
| 120 | 1,440 | 3,640 | 2,400 | ** | ** |

A1000/A1001 - ELEMENTS OF SECTION

| Parameter | A1000 | A1001 |
|------------------------|-----------------------|-----------------------|
| Area of Section | 0.305 In ² | 0.609 In ² |
| Axis 1-1 | | |
| Moment of Inertia (I) | 0.061 In ⁴ | 0.302 In ⁴ |
| Section Modulus (S) | 0.086 In ³ | 0.242 In ³ |
| Radius of Gyration (r) | 0.447 In | 0.704 In |
| Axis 2-2 | | |
| Moment of Inertia (I) | 0.078 In ⁴ | 0.156 In ⁴ |
| Section Modulus (S) | 0.125 In ³ | 0.250 In ³ |
| Radius of Gyration (r) | 0.506 In | 0.506 In |

Notes:

* Load limited by spot weld shear.

** $K_L/r > 200$

- Above loads include the weight of the member. This weight must be deducted to arrive at the net allowable load the beam will support.
- Long span beams should be supported in such a manner as to prevent rotation and twist.
- Allowable uniformly distributed loads are listed for various simple spans, that is, a beam on two supports. If load is concentrated at the center of the span, multiply load from the table by 0.5 and corresponding deflection by 0.8.



A1000 - BEAM LOADING (METRIC)

| Span mm | Max Allowable Uniform Load kN | Defl. at Uniform Load mm | Uniform Loading at Deflection | | |
|---------|-------------------------------|--------------------------|-------------------------------|-------------|-------------|
| | | | Span/180 kN | Span/240 kN | Span/360 kN |
| 600 | 3.2 | 2 | 3.2 | 3.2 | 3.1 |
| 750 | 2.6 | 3 | 2.6 | 2.6 | 2.0 |
| 1,000 | 2.0 | 5 | 2.0 | 1.6 | 1.1 |
| 1,250 | 1.6 | 8 | 1.4 | 1.1 | 0.7 |
| 1,500 | 1.3 | 11 | 1.0 | 0.7 | 0.5 |
| 1,750 | 1.1 | 15 | 0.7 | 0.5 | 0.4 |
| 2,000 | 1.0 | 20 | 0.5 | 0.4 | 0.3 |
| 2,500 | 0.8 | 32 | 0.4 | 0.3 | 0.2 |
| 3,000 | 0.7 | 46 | 0.2 | 0.2 | 0.1 |

A1001 - BEAM LOADING (METRIC)

| Span mm | Max Allowable Uniform Load kN | Defl. at Uniform Load mm | Uniform Loading at Deflection | | |
|---------|-------------------------------|--------------------------|-------------------------------|-------------|-------------|
| | | | Span/180 kN | Span/240 kN | Span/360 kN |
| 600 | 7.3* | 1 | 7.3* | 7.3* | 7.3 |
| 750 | 7.3* | 2 | 7.3* | 7.3* | 7.3 |
| 1,000 | 5.5 | 3 | 5.5 | 5.5 | 5.5 |
| 1,250 | 4.4 | 4 | 4.4 | 4.4 | 3.5 |
| 1,500 | 3.6 | 6 | 3.6 | 3.6 | 2.4 |
| 1,750 | 3.2 | 9 | 3.2 | 2.7 | 1.8 |
| 2,000 | 2.8 | 11 | 2.7 | 2.0 | 1.4 |
| 2,500 | 2.2 | 17 | 1.7 | 1.3 | 0.9 |
| 3,000 | 1.8 | 25 | 1.2 | 0.9 | 0.6 |
| 3,500 | 1.6 | 34 | 0.9 | 0.7 | 0.4 |

A1000 - COLUMN LOADING (METRIC)

| Unbraced Height mm | Maximum Allowable Load at Slot Face kN | Max. Column Load Applied at C.G. | | | |
|--------------------|--|----------------------------------|-------------|------------|------------|
| | | K = 0.65 kN | K = 0.80 kN | K = 1.0 kN | K = 1.2 kN |
| 600 | 8.2 | 23.4 | 20.7 | 17.3 | 14.6 |
| 750 | 7.5 | 20.5 | 17.3 | 14.0 | 11.3 |
| 1,000 | 6.3 | 16.2 | 13.0 | 9.9 | 8.1 |
| 1,250 | 5.3 | 12.8 | 9.9 | 7.7 | 6.3 |
| 1,500 | 4.6 | 10.2 | 8.1 | 6.3 | 5.2 |
| 1,750 | 4.1 | 8.6 | 6.8 | 5.3 | 4.3 |
| 2,000 | 3.6 | 7.4 | 5.9 | 4.5 | ** |
| 2,250 | 3.3 | 6.5 | 5.2 | 3.9 | ** |
| 2,500 | 3.0 | 5.8 | 4.5 | ** | ** |
| 2,750 | 2.7 | 5.2 | 4.0 | ** | ** |

A1001 - COLUMN LOADING (METRIC)

| Unbraced Height mm | Maximum Allowable Load at Slot Face kN | Max. Column Load Applied at C.G. | | | |
|--------------------|--|----------------------------------|-------------|------------|------------|
| | | K = 0.65 kN | K = 0.80 kN | K = 1.0 kN | K = 1.2 kN |
| 600 | 15.5 | 56.9 | 54.5 | 51.6 | 48.9 |
| 750 | 15.2 | 54.4 | 51.6 | 48.4 | 45.7 |
| 1,000 | 14.9 | 50.4 | 47.4 | 43.9 | 37.4 |
| 1,250 | 14.4 | 47.2 | 43.9 | 35.7 | 27.8 |
| 1,500 | 13.3 | 44.6 | 37.4 | 27.8 | 19.6 |
| 1,750 | 12.1 | 39.4 | 30.9 | 20.7 | 14.4 |
| 2,000 | 10.8 | 34.1 | 24.8 | 15.9 | 11.0 |
| 2,250 | 9.5 | 29.0 | 19.6 | 12.5 | ** |
| 2,500 | 8.4 | 24.1 | 15.9 | 10.2 | ** |
| 2,750 | 7.4 | 19.9 | 13.1 | ** | ** |

A1000/A1001 - ELEMENTS OF SECTION (METRIC)

| Parameter | A1000 | A1001 |
|------------------------|----------------------|-----------------------|
| Area of Section | 1.96 cm ² | 3.93 cm ² |
| Axis 1-1 | | |
| Moment of Inertia (I) | 2.53 cm ⁴ | 12.57 cm ⁴ |
| Section Modulus (S) | 1.41 cm ³ | 3.96 cm ³ |
| Radius of Gyration (r) | 1.14 cm | 1.79 cm |
| Axis 2-2 | | |
| Moment of Inertia (I) | 3.25 cm ⁴ | 6.50 cm ⁴ |
| Section Modulus (S) | 2.05 cm ³ | 4.09 cm ³ |
| Radius of Gyration (r) | 1.29 cm | 1.29 cm |

Notes:

* Load limited by spot weld shear.

** $KL/r > 200$

- Above loads include the weight of the member. This weight must be deducted to arrive at the net allowable load the beam will support.
- Long span beams should be supported in such a manner as to prevent rotation and twist.
- Allowable uniformly distributed loads are listed for various simple spans, that is, a beam on two supports. If load is concentrated at the center of the span, multiply load from the table by 0.5 and corresponding deflection by 0.8.

Finishes: PL, GR, HG, PG Standard Lengths: 10' & 20'

A1001A - 1 1/4" x 2 1/2"

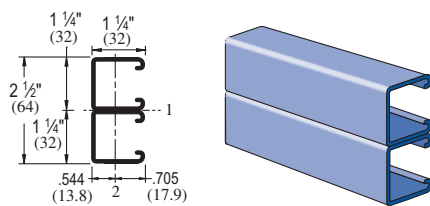

Wt/100 Ft: 207 Lbs (308 kg/100m)
 Allowable Moment 7,930 In-Lbs (900 N•m)
 14 Gauge Nominal Thickness .075" (1.9mm)

A1001B - 1 1/4" x 2 1/2"

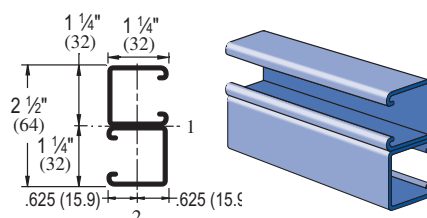

Wt/100 Ft: 207 Lbs (308 kg/100m)
 Allowable Moment 7,930 In-Lbs (900 N•m)
 14 Gauge Nominal Thickness .075" (1.9mm)

A1001C - 1 1/4" x 2 1/2"

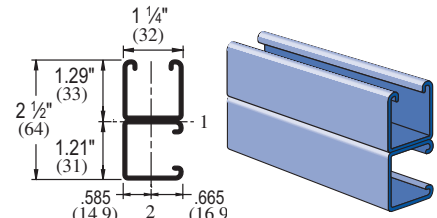

Wt/100 Ft: 207 Lbs (308 kg/100m)
 Allowable Moment 6,760 In-Lbs (760 N•m)
 14 Gauge Nominal Thickness .075" (1.9mm)

15/16" Channel
 Telesruct System
 Nuts & Hardware
 General Fittings
 Pipe/Conduit Supports
 Electrical Fittings
 Concrete Inserts
 1 1/4" Framing System
 1 3/16" Framing System
 Fiberglass System
 Special Metals
 PrimeAngle System
 Product Index

A3300 – 1 1/4" x 3/4"

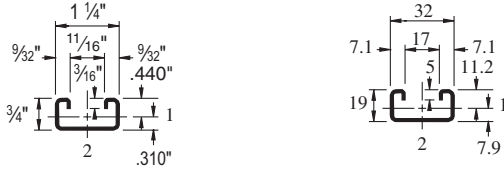
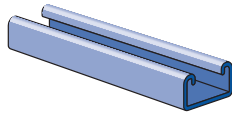

Wt/100 Ft: 78 Lbs (116 kg/100m)
 Allowable Moment 950 In-Lbs (110 N•m)
 14 Gauge Nominal Thickness .075" (1.9mm)

A3301 – 1 1/4" x 1 1/2"

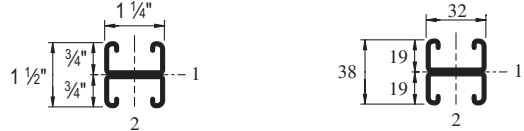
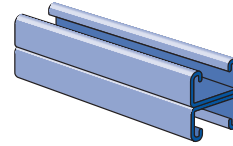

Wt/100 Ft: 156 Lbs (232 kg/100m)
 Allowable Moment 2,590 In-Lbs (290 N•m)
 14 Gauge Nominal Thickness .075" (1.9mm)

A3300 - BEAM LOADING

| Span In | Max Allowable Uniform Load Lbs | Defl. at Uniform Load In | Uniform Loading at Deflection | | |
|---------|--------------------------------|--------------------------|-------------------------------|--------------|--------------|
| | | | Span/180 Lbs | Span/240 Lbs | Span/360 Lbs |
| 18 | 420 | 0.07 | 420 | 420 | 320 |
| 24 | 320 | 0.12 | 320 | 270 | 180 |
| 36 | 210 | 0.26 | 160 | 120 | 80 |
| 48 | 160 | 0.47 | 90 | 70 | 50 |
| 60 | 130 | 0.75 | 60 | 40 | 30 |
| 72 | 110 | 1.09 | 40 | 30 | 20 |
| 84 | 90 | 1.42 | 30 | 20 | 10 |
| 96 | 80 | 1.88 | 20 | 20 | 10 |

A3301 - BEAM LOADING

| Span In | Max Allowable Uniform Load Lbs | Defl. at Uniform Load In | Uniform Loading at Deflection | | |
|---------|--------------------------------|--------------------------|-------------------------------|--------------|--------------|
| | | | Span/180 Lbs | Span/240 Lbs | Span/360 Lbs |
| 18 | 990* | 0.03 | 990* | 990* | 990* |
| 24 | 860 | 0.07 | 860 | 860 | 850 |
| 36 | 580 | 0.15 | 580 | 560 | 380 |
| 48 | 430 | 0.27 | 420 | 320 | 210 |
| 60 | 350 | 0.43 | 270 | 200 | 140 |
| 72 | 290 | 0.62 | 190 | 140 | 90 |
| 84 | 250 | 0.85 | 140 | 100 | 70 |
| 96 | 220 | 1.11 | 110 | 80 | 50 |

A3300 - COLUMN LOADING

| Unbraced Height In | Maximum Allowable Load at Slot Face Lbs | Max. Column Load Applied at C.G. | | | |
|--------------------|---|----------------------------------|--------------|-------------|-------------|
| | | K = 0.65 Lbs | K = 0.80 Lbs | K = 1.0 Lbs | K = 1.2 Lbs |
| 18 | 1,430 | 4,490 | 4,210 | 3,860 | 3,550 |
| 24 | 1,370 | 4,090 | 3,750 | 3,310 | 2,680 |
| 36 | 1,190 | 3,390 | 2,680 | 1,820 | 1,260 |
| 48 | 900 | 2,380 | 1,600 | 1,020 | ** |
| 60 | 680 | 1,550 | 1,020 | ** | ** |

A3301 - COLUMN LOADING

| Unbraced Height In | Maximum Allowable Load at Slot Face Lbs | Max. Column Load Applied at C.G. | | | |
|--------------------|---|----------------------------------|--------------|-------------|-------------|
| | | K = 0.65 Lbs | K = 0.80 Lbs | K = 1.0 Lbs | K = 1.2 Lbs |
| 18 | 2,540 | 9,890 | 9,620 | 9,300 | 9,020 |
| 24 | 2,510 | 9,510 | 9,200 | 8,710 | 7,960 |
| 36 | 2,410 | 8,800 | 7,960 | 6,730 | 5,490 |
| 48 | 2,230 | 7,560 | 6,320 | 4,690 | 3,310 |
| 60 | 1,970 | 6,210 | 4,690 | 3,050 | 2,120 |
| 72 | 1,650 | 4,890 | 3,310 | 2,120 | ** |
| 84 | 1,380 | 3,680 | 2,430 | ** | ** |
| 96 | 1,160 | 2,820 | 1,860 | ** | ** |

A3300/A3301 - ELEMENTS OF SECTION

| Parameter | A3300 | A3301 |
|------------------------|-----------------------|-----------------------|
| Area of Section | 0.230 In ² | 0.459 In ² |
| Axis 1-1 | | |
| Moment of Inertia (I) | 0.017 In ⁴ | 0.077 In ⁴ |
| Section Modulus (S) | 0.038 In ³ | 0.103 In ³ |
| Radius of Gyration (r) | 0.269 In | 0.411 In |
| Axis 2-2 | | |
| Moment of Inertia (I) | 0.052 In ⁴ | 0.104 In ⁴ |
| Section Modulus (S) | 0.083 In ³ | 0.167 In ³ |
| Radius of Gyration (r) | 0.477 In | 0.477 In |

Notes:

* Load limited by spot weld shear.

** $KL/r > 200$

- Above loads include the weight of the member. This weight must be deducted to arrive at the net allowable load the beam will support.
- Long span beams should be supported in such a manner as to prevent rotation and twist.
- Allowable uniformly distributed loads are listed for various simple spans, that is, a beam on two supports. If load is concentrated at the center of the span, multiply load from the table by 0.5 and corresponding deflection by 0.8.



A3300 - BEAM LOADING (METRIC)

| Span mm | Max Allowable Uniform Load kN | Defl. at Uniform Load mm | Uniform Loading at Deflection | | |
|---------|-------------------------------|--------------------------|-------------------------------|-------------|-------------|
| | | | Span/180 kN | Span/240 kN | Span/360 kN |
| 600 | 1.4 | 3 | 1.4 | 1.2 | 0.8 |
| 750 | 1.2 | 5 | 1.1 | 0.8 | 0.5 |
| 1,000 | 0.8 | 8 | 0.6 | 0.4 | 0.3 |
| 1,250 | 0.7 | 12 | 0.4 | 0.3 | 0.2 |
| 1,500 | 0.6 | 18 | 0.3 | 0.2 | 0.1 |
| 1,750 | 0.5 | 24 | 0.2 | 0.1 | 0.1 |
| 2,000 | 0.4 | 33 | 0.1 | 0.1 | 0.1 |

A3301 - BEAM LOADING (METRIC)

| Span mm | Max Allowable Uniform Load kN | Defl. at Uniform Load mm | Uniform Loading at Deflection | | |
|---------|-------------------------------|--------------------------|-------------------------------|-------------|-------------|
| | | | Span/180 kN | Span/240 kN | Span/360 kN |
| 600 | 3.9 | 2 | 3.9 | 3.9 | 3.9 |
| 750 | 3.1 | 3 | 3.1 | 3.1 | 2.5 |
| 1,000 | 2.4 | 5 | 2.4 | 2.1 | 1.4 |
| 1,250 | 1.9 | 7 | 1.8 | 1.3 | 0.9 |
| 1,500 | 1.6 | 10 | 1.2 | 0.9 | 0.6 |
| 1,750 | 1.3 | 14 | 0.9 | 0.7 | 0.4 |
| 2,000 | 1.2 | 18 | 0.7 | 0.5 | 0.4 |
| 2,500 | 0.9 | 29 | 0.4 | 0.4 | 0.2 |
| 3,000 | 0.8 | 43 | 0.3 | 0.2 | 0.1 |

A3300 - COLUMN LOADING (METRIC)

| Unbraced Height mm | Maximum Allowable Load at Slot Face kN | Max. Column Load Applied at C.G. | | | |
|--------------------|--|----------------------------------|-------------|------------|------------|
| | | K = 0.65 kN | K = 0.80 kN | K = 1.0 kN | K = 1.2 kN |
| 600 | 6.1 | 18.3 | 16.8 | 14.9 | 12.2 |
| 750 | 5.8 | 16.7 | 14.9 | 11.5 | 8.4 |
| 1,000 | 4.9 | 13.8 | 10.4 | 6.8 | 4.7 |
| 1,250 | 3.9 | 10.1 | 6.8 | 4.3 | ** |
| 1,500 | 3.1 | 7.1 | 4.7 | ** | ** |

A3301 - COLUMN LOADING (METRIC)

| Unbraced Height mm | Maximum Allowable Load at Slot Face kN | Max. Column Load Applied at C.G. | | | |
|--------------------|--|----------------------------------|-------------|------------|------------|
| | | K = 0.65 kN | K = 0.80 kN | K = 1.0 kN | K = 1.2 kN |
| 600 | 11.2 | 42.4 | 41.0 | 39.0 | 35.7 |
| 750 | 11.0 | 40.9 | 39.0 | 34.9 | 30.4 |
| 1,000 | 10.5 | 37.7 | 33.4 | 27.4 | 21.4 |
| 1,250 | 9.8 | 33.0 | 27.4 | 20.0 | 14.0 |
| 1,500 | 8.9 | 28.1 | 21.4 | 14.0 | 9.7 |
| 1,750 | 7.7 | 23.2 | 16.1 | 10.3 | ** |
| 2,000 | 6.7 | 18.6 | 12.3 | 7.9 | ** |
| 2,250 | 5.8 | 14.7 | 9.7 | ** | ** |
| 2,500 | 5.0 | 11.9 | 7.9 | ** | ** |

A3300/A3301 - ELEMENTS OF SECTION (METRIC)

| Parameter | A3300 | | A3301 | |
|------------------------|-------|-----------------|-------|-----------------|
| Area of Section | 1.48 | cm ² | 2.96 | cm ² |
| Axis 1-1 | | | | |
| Moment of Inertia (I) | 0.69 | cm ⁴ | 3.22 | cm ⁴ |
| Section Modulus (S) | 0.62 | cm ³ | 1.69 | cm ³ |
| Radius of Gyration (r) | 0.68 | cm | 1.04 | cm |
| Axis 2-2 | | | | |
| Moment of Inertia (I) | 2.17 | cm ⁴ | 4.34 | cm ⁴ |
| Section Modulus (S) | 1.37 | cm ³ | 2.73 | cm ³ |
| Radius of Gyration (r) | 1.21 | cm | 1.21 | cm |

Notes:

* Load limited by spot weld shear.

** $kl/r > 200$

- Above loads include the weight of the member. This weight must be deducted to arrive at the net allowable load the beam will support.
- Long span beams should be supported in such a manner as to prevent rotation and twist.
- Allowable uniformly distributed loads are listed for various simple spans, that is, a beam on two supports. If load is concentrated at the center of the span, multiply load from the table by 0.5 and corresponding deflection by 0.8.

1 1/4" Framing System
 Product Index
 PrimeAngle System
 Special Metals
 Fiberglass System
 1 3/16" Framing System
 1 1/4" Framing System
 Concrete Inserts
 Electrical Fittings
 Pipe/Conduit Supports
 General Fittings
 Hardware
 Telestrut System
 Channel
 1 5/8"

A4000 – 1 1/4" x 5/8"

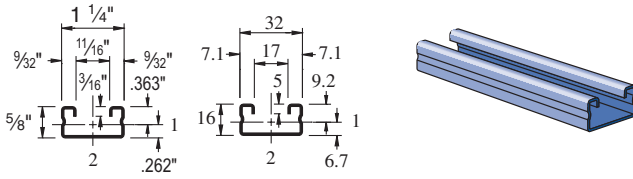

Wt/100 Ft: 45 Lbs (67 kg/100m)
 Allowable Moment 560 In-Lbs (60 N•m)
 19 Gauge Nominal Thickness .040" (1.0mm)

A4001– 1 1/4" x 1 1/4"

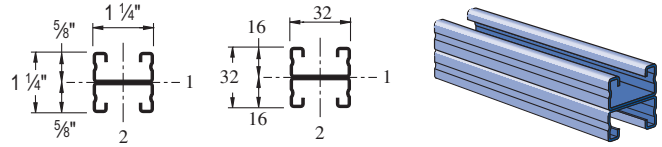

Wt/100 Ft: 90 Lbs (134 kg/100m)
 Allowable Moment 1,470 In-Lbs (170 N•m)
 19 Gauge Nominal Thickness .040" (1.0mm)

A4000 - BEAM LOADING

| Span In | Max Allowable Uniform Load Lbs | Defl. at Uniform Load In | Uniform Loading at Deflection | | |
|---------|--------------------------------|--------------------------|-------------------------------|--------------|--------------|
| | | | Span/180 Lbs | Span/240 Lbs | Span/360 Lbs |
| 18 | 250 | 0.08 | 250 | 220 | 150 |
| 24 | 190 | 0.15 | 170 | 120 | 80 |
| 36 | 120 | 0.32 | 70 | 60 | 40 |
| 48 | 90 | 0.58 | 40 | 30 | 20 |
| 60 | 70 | 0.88 | 30 | 20 | 10 |
| 72 | 60 | 1.30 | 20 | 10 | 10 |

A4001 - BEAM LOADING

| Span In | Max Allowable Uniform Load Lbs | Defl. at Uniform Load In | Uniform Loading at Deflection | | |
|---------|--------------------------------|--------------------------|-------------------------------|--------------|--------------|
| | | | Span/180 Lbs | Span/240 Lbs | Span/360 Lbs |
| 18 | 350* | 0.02 | 350* | 350* | 350* |
| 24 | 350* | 0.06 | 350* | 350* | 350* |
| 36 | 330 | 0.19 | 330 | 270 | 180 |
| 48 | 240 | 0.32 | 200 | 150 | 100 |
| 60 | 200 | 0.52 | 130 | 100 | 60 |
| 72 | 160 | 0.72 | 90 | 70 | 40 |
| 84 | 140 | 1.00 | 70 | 50 | 30 |

A4000 - COLUMN LOADING

| Unbraced Height In | Maximum Allowable Load at Slot Face Lbs | Max. Column Load Applied at C.G. | | | |
|--------------------|---|----------------------------------|--------------|-------------|-------------|
| | | K = 0.65 Lbs | K = 0.80 Lbs | K = 1.0 Lbs | K = 1.2 Lbs |
| 18 | 960 | 2,510 | 2,290 | 1,990 | 1,700 |
| 24 | 880 | 2,190 | 1,890 | 1,530 | 1,230 |
| 36 | 670 | 1,570 | 1,230 | 830 | 580 |
| 48 | 470 | 1,110 | 730 | 470 | ** |
| 60 | 340 | 710 | 470 | ** | ** |

A4001 - COLUMN LOADING

| Unbraced Height In | Maximum Allowable Load at Slot Face Lbs | Max. Column Load Applied at C.G. | | | |
|--------------------|---|----------------------------------|--------------|-------------|-------------|
| | | K = 0.65 Lbs | K = 0.80 Lbs | K = 1.0 Lbs | K = 1.2 Lbs |
| 18 | 1,640 | 5,640 | 5,420 | 5,110 | 4,800 |
| 24 | 1,600 | 5,320 | 5,000 | 4,600 | 4,240 |
| 36 | 1,510 | 4,650 | 4,240 | 3,500 | 2,730 |
| 48 | 1,330 | 4,030 | 3,240 | 2,250 | 1,560 |
| 60 | 1,090 | 3,170 | 2,250 | 1,440 | 1,000 |
| 72 | 870 | 2,370 | 1,560 | 1,000 | ** |
| 84 | 700 | 1,740 | 1,150 | ** | ** |

A4000/A4001 - ELEMENTS OF SECTION

| Parameter | A4000 | A4001 |
|------------------------|-----------------|-----------------|
| Area of Section | 0.132 | 0.264 |
| Axis 1-1 | In ² | In ² |
| Moment of Inertia (I) | 0.008 | 0.037 |
| Section Modulus (S) | 0.022 | 0.058 |
| Radius of Gyration (r) | 0.240 | 0.372 |
| Axis 2-2 | In | In |
| Moment of Inertia (I) | 0.029 | 0.058 |
| Section Modulus (S) | 0.046 | 0.093 |
| Radius of Gyration (r) | 0.469 | 0.469 |

Notes:

* Load limited by spot weld shear.

** $KL/r > 200$

- Above loads include the weight of the member. This weight must be deducted to arrive at the net allowable load the beam will support.
- Long span beams should be supported in such a manner as to prevent rotation and twist.
- Allowable uniformly distributed loads are listed for various simple spans, that is, a beam on two supports. If load is concentrated at the center of the span, multiply load from the table by 0.5 and corresponding deflection by 0.8.



A4000 - BEAM LOADING (METRIC)

| Span mm | Max Allowable Uniform Load kN | Defl. at Uniform Load mm | Uniform Loading at Deflection | | |
|------------|--|-----------------------------------|-------------------------------|----------------|----------------|
| | | | Span/180 kN | Span/240 kN | Span/360 kN |
| 600 | 0.8 | 4 | 0.8 | 0.6 | 0.4 |
| 750 | 0.7 | 6 | 0.5 | 0.4 | 0.3 |
| 1,000 | 0.5 | 10 | 0.3 | 0.2 | 0.1 |
| 1,250 | 0.4 | 16 | 0.2 | 0.1 | 0.1 |
| 1,500 | 0.4 | 24 | 0.1 | 0.1 | 0.0 |

A4001 - BEAM LOADING (METRIC)

| Span mm | Max Allowable Uniform Load kN | Defl. at Uniform Load mm | Uniform Loading at Deflection | | |
|------------|--|-----------------------------------|-------------------------------|----------------|----------------|
| | | | Span/180 kN | Span/240 kN | Span/360 kN |
| 600 | 1.6* | 1 | 1.6* | 1.6* | 1.6 |
| 750 | 1.6* | 3 | 1.6* | 1.6* | 1.2 |
| 1,000 | 1.3 | 6 | 1.3 | 1.0 | 0.7 |
| 1,250 | 1.1 | 9 | 0.8 | 0.6 | 0.4 |
| 1,500 | 0.9 | 13 | 0.6 | 0.4 | 0.3 |
| 1,750 | 0.8 | 17 | 0.4 | 0.3 | 0.2 |
| 2,000 | 0.7 | 22 | 0.3 | 0.3 | 0.2 |

A4000 - COLUMN LOADING (METRIC)

| Unbraced Height mm | Maximum Allowable Load at Slot Face kN | Max. Column Load Applied at C.G. | | | |
|--------------------------|--|----------------------------------|----------------|---------------|---------------|
| | | K = 0.65 kN | K = 0.80 kN | K = 1.0 kN | K = 1.2 kN |
| 600 | 3.9 | 9.8 | 8.5 | 6.9 | 5.6 |
| 750 | 3.5 | 8.4 | 6.9 | 5.3 | 3.8 |
| 1,000 | 2.8 | 6.4 | 4.8 | 3.1 | 2.1 |
| 1,250 | 2.0 | 4.7 | 3.1 | ** | ** |
| 1,500 | 1.5 | 3.2 | 2.1 | ** | ** |

A4001 - COLUMN LOADING (METRIC)

| Unbraced Height mm | Maximum Allowable Load at Slot Face kN | Max. Column Load Applied at C.G. | | | |
|--------------------------|--|----------------------------------|----------------|---------------|---------------|
| | | K = 0.65 kN | K = 0.80 kN | K = 1.0 kN | K = 1.2 kN |
| 600 | 7.1 | 23.8 | 22.4 | 20.6 | 19.0 |
| 750 | 6.9 | 22.3 | 20.6 | 18.6 | 15.8 |
| 1,000 | 6.6 | 19.9 | 17.8 | 13.9 | 10.3 |
| 1,250 | 5.8 | 17.5 | 13.9 | 9.5 | 6.6 |
| 1,500 | 4.9 | 14.4 | 10.3 | 6.6 | 4.6 |
| 1,750 | 4.1 | 11.4 | 7.6 | 4.8 | ** |
| 2,000 | 3.4 | 8.8 | 5.8 | ** | ** |
| 2,250 | 2.9 | 6.9 | 4.6 | ** | ** |

A4000/A4001 - ELEMENTS OF SECTION (METRIC)

| Parameter | A4000 | | A4001 | |
|------------------------|-------|-----------------|-------|-----------------|
| Area of Section | 0.85 | cm ² | 1.70 | cm ² |
| Axis 1-1 | | | | |
| Moment of Inertia (I) | 0.32 | cm ⁴ | 1.52 | cm ⁴ |
| Section Modulus (S) | 0.37 | cm ³ | 0.96 | cm ³ |
| Radius of Gyration (r) | 0.61 | cm | 0.94 | cm |
| Axis 2-2 | | | | |
| Moment of Inertia (I) | 1.21 | cm ⁴ | 2.42 | cm ⁴ |
| Section Modulus (S) | 0.76 | cm ³ | 1.52 | cm ³ |
| Radius of Gyration (r) | 1.19 | cm | 1.19 | cm |

Notes:

* Load limited by spot weld shear.

** $KL/r > 200$

- Above loads include the weight of the member. This weight must be deducted to arrive at the net allowable load the beam will support.
- Long span beams should be supported in such a manner as to prevent rotation and twist.
- Allowable uniformly distributed loads are listed for various simple spans, that is, a beam on two supports. If load is concentrated at the center of the span, multiply load from the table by 0.5 and corresponding deflection by 0.8.

15/16" Channel
 Teleslur System
 Nuts & Hardware
 General Fittings
 Pipe/Conduit Supports
 Electrical Fittings
 Concrete Inserts
 1 1/4" Framing System
 1 3/16" Framing System
 Fiberglass System
 Special Metals
 PrimeAngle System
 Product Index

A5000 – 1¼" x 2½"

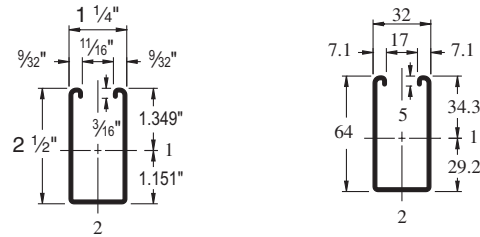
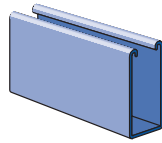

Wt/100 Ft: 167 Lbs (249 kg/100m)
 Allowable Moment 6,670 In-Lbs (750 N•m)
 14 Gauge Nominal Thickness .075" (1.9mm)

A5000 - BEAM LOADING

| Span In | Max Allowable Uniform Load Lbs | Defl. at Uniform Load Lbs | Uniform Loading at Deflection | | |
|---------|--------------------------------|---------------------------|-------------------------------|--------------|--------------|
| | | | Span/180 Lbs | Span/240 Lbs | Span/360 Lbs |
| 24 | 2,220 | 0.04 | 2,220 | 2,220 | 2,220 |
| 36 | 1,480 | 0.09 | 1,480 | 1,480 | 1,480 |
| 48 | 1,110 | 0.15 | 1,110 | 1,110 | 980 |
| 60 | 890 | 0.24 | 890 | 890 | 630 |
| 72 | 740 | 0.34 | 740 | 650 | 430 |
| 84 | 640 | 0.47 | 640 | 480 | 320 |
| 96 | 560 | 0.61 | 490 | 370 | 240 |
| 108 | 490 | 0.76 | 390 | 290 | 190 |
| 120 | 440 | 0.94 | 310 | 230 | 160 |

A5000 - BEAM LOADING (METRIC)

| Span mm | Max Allowable Uniform Load kN | Defl. at Uniform Load mm | Uniform Loading at Deflection | | |
|---------|-------------------------------|--------------------------|-------------------------------|-------------|-------------|
| | | | Span/180 kN | Span/240 kN | Span/360 kN |
| 600 | 10.1 | 1 | 10.1 | 10.1 | 10.1 |
| 750 | 8.1 | 1 | 8.1 | 8.1 | 8.1 |
| 1,000 | 6.1 | 3 | 6.1 | 6.1 | 6.1 |
| 1,250 | 4.8 | 4 | 4.8 | 4.8 | 4.1 |
| 1,500 | 4.0 | 6 | 4.0 | 4.0 | 2.9 |
| 1,750 | 3.4 | 8 | 3.4 | 3.2 | 2.1 |
| 2,000 | 3.0 | 10 | 3.0 | 2.4 | 1.6 |
| 2,500 | 2.4 | 16 | 2.1 | 1.6 | 1.0 |
| 3,000 | 2.0 | 23 | 1.4 | 1.1 | 0.7 |

A5000 - COLUMN LOADING

| Unbraced Height In | Maximum Allowable Load at Slot Face Lbs | Max. Column Load Applied at C.G. | | | |
|--------------------|---|----------------------------------|--------------|-------------|-------------|
| | | K = 0.65 Lbs | K = 0.80 Lbs | K = 1.0 Lbs | K = 1.2 Lbs |
| 24 | 2,790 | 7,950 | 6,670 | 5,080 | 3,760 |
| 36 | 1,950 | 5,270 | 3,760 | 2,600 | 1,970 |
| 48 | 1,360 | 3,290 | 2,350 | 1,690 | 1,330 |
| 60 | 990 | 2,300 | 1,690 | 1,260 | 1,010 |
| 72 | 790 | 1,750 | 1,330 | 1,010 | 830 |
| 84 | 660 | 1,420 | 1,100 | 860 | 710 |
| 96 | 570 | 1,200 | 940 | 740 | ** |
| 108 | 510 | 1,040 | 830 | ** | ** |
| 120 | 460 | 930 | 740 | ** | ** |

A5000 - COLUMN LOADING (METRIC)

| Unbraced Height mm | Maximum Allowable Load at Slot Face kN | Max. Column Load Applied at C.G. | | | |
|--------------------|--|----------------------------------|-------------|------------|------------|
| | | K = 0.65 kN | K = 0.80 kN | K = 1.0 kN | K = 1.2 kN |
| 600 | 12.5 | 35.8 | 30.2 | 23.1 | 17.2 |
| 750 | 10.7 | 29.7 | 23.1 | 16.0 | 11.9 |
| 1,000 | 7.8 | 20.5 | 14.4 | 10.1 | 7.7 |
| 1,250 | 5.8 | 14.0 | 10.1 | 7.3 | 5.7 |
| 1,500 | 4.5 | 10.5 | 7.7 | 5.7 | 4.6 |
| 1,750 | 3.7 | 8.3 | 6.2 | 4.8 | 3.9 |
| 2,000 | 3.2 | 6.9 | 5.3 | 4.1 | 3.3 |
| 2,250 | 2.8 | 5.9 | 4.6 | 3.6 | 3.0 |
| 2,500 | 2.5 | 5.2 | 4.1 | 3.2 | ** |

A5000 - ELEMENTS OF SECTION

| Parameter | A5000 | |
|------------------------|-------|-----------------|
| Area of Section | 0.492 | In ² |
| Axis 1-1 | | |
| Moment of Inertia (I) | 0.358 | In ⁴ |
| Section Modulus (S) | 0.265 | In ³ |
| Radius of Gyration (r) | 0.853 | In |
| Axis 2-2 | | |
| Moment of Inertia (I) | 0.143 | In ⁴ |
| Section Modulus (S) | 0.229 | In ³ |
| Radius of Gyration (r) | 0.539 | In |

A5000 - ELEMENTS OF SECTION (METRIC)

| Parameter | A5000 | |
|------------------------|-------|-----------------|
| Area of Section | 3.17 | cm ² |
| Axis 1-1 | | |
| Moment of Inertia (I) | 14.91 | cm ⁴ |
| Section Modulus (S) | 4.35 | cm ³ |
| Radius of Gyration (r) | 2.17 | cm |
| Axis 2-2 | | |
| Moment of Inertia (I) | 5.94 | cm ⁴ |
| Section Modulus (S) | 3.74 | cm ³ |
| Radius of Gyration (r) | 1.37 | cm |

Notes:

* Load limited by spot weld shear.

** KL/r > 200

- Above loads include the weight of the member. This weight must be deducted to arrive at the net allowable load the beam will support.
- Long span beams should be supported in such a manner as to prevent rotation and twist.
- Allowable uniformly distributed loads are listed for various simple spans, that is, a beam on two supports. If load is concentrated at the center of the span, multiply load from the table by 0.5 and corresponding deflection by 0.8.



BEARING LOADS ON UNISTRUT CHANNEL

| | | | |
|---|---|---|---|
| Loads are calculated based on 2001 Specification For The Design Of Cold Formed Steel Structural Members published by AISI | | | |
| | Bearing Length 1 1/4" (32 mm) Maximum Allowable Loads - Lbs (kN) | Bearing Length 1 1/4" (32 mm) Maximum Allowable Loads - Lbs (kN) | Bearing Length 2 1/2" (64 mm) Maximum Allowable Loads - Lbs (kN) |
| Channel | | | |
| A1000 | 3,700 (16.46) | 1,700 (7.56) | 4,300 (19.13) |
| A3300 | 3,800 (16.90) | 1,700 (7.56) | 4,300 (19.13) |
| A4000 | 1,200 (5.34) | 600 (2.67) | 1,400 (6.23) |
| A5000 | 3,600 (16.01) | 1,600 (7.12) | 4,200 (18.68) |

MAXIMUM ALLOWABLE PULL-OUT AND SLIP LOADS

| Nut Size/ Thread | Channel | Gauge | Max Allowable Pull-Out Lbs (kN) | Resistance to Slip Lbs (kN) | Torque Ft-Lbs (N·m) |
|---------------------|---------|-------|---------------------------------------|-----------------------------------|------------------------|
| 3/8" -16 | A1000 | 14 | 900 | 500 | 19 |
| | | | 4.00 | 2.22 | 26 |
| 5/16" -18 | A3300 | 14 | 900 | 500 | 11 |
| | | | 4.00 | 2.22 | 15 |
| 1/4" -20 | A5000 | 14 | 900 | 500 | 6 |
| | | | 4.00 | 2.22 | 8 |
| 3/8" -16 | A4000 | 19 | 300 | 400 | 19 |
| | | | 1.33 | 1.78 | 26 |

Nut design loads include a minimum safety factor of 3.

CHANNEL NUT WITH SPRING

| | | | | |
|--|-------------|-----------------|---------------------|--------------|
| | Part Number | Nut Size Thread | Wt/100 pcs Lbs (kg) | Use With |
| | A1006-1420 | 1/4" -20 | 6 (2.7) | A1000 |
| | A1007 | 5/16" -18 | 6 (2.7) | |
| | A1008 | 3/8" -16 | 6 (2.7) | |
| | Part Number | Nut Size Thread | Wt/100 pcs Lbs (kg) | Use With |
| | A4006-1420 | 1/4" -20 | 5 (2.3) | A3300, A4000 |
| | A4007 | 5/16" -18 | 5 (2.3) | |
| | A4008 | 3/8" -16 | 5 (2.3) | |
| | Part Number | Nut Size Thread | Wt/100 pcs Lbs (kg) | Use With |
| | A5506-1420 | 1/4" -20 | 6 (2.7) | A5000 |
| | A5007 | 5/16" -18 | 6 (2.7) | |
| | A5508 | 3/8" -16 | 6 (2.7) | |

CHANNEL NUT WITHOUT SPRINGS

| | | | | |
|--|-------------|-----------------|---------------------|------------------------------|
| | Part Number | Nut Size Thread | Wt/100 pcs Lbs (kg) | Use With |
| | A3006-1420 | 1/4" -20 | 5 (2.3) | A1000, A3300, A4000, & A5000 |
| | A3007 | 5/16" -18 | 5 (2.3) | |
| | A3008 | 3/8" -16 | 5 (2.3) | |
| | Part Number | Nut Size Thread | Wt/100 pcs Lbs (kg) | Use With |
| | A3016-0832 | #8 -32 | 1 (0.5) | A1000, A3300, A4000, & A5000 |
| | A3016-1024 | #10 -24 | 1 (0.5) | |
| | A3016-1032 | #10 -32 | 1 (0.5) | |
| | A3016-1420 | 1/4" -20 | 1 (0.5) | |

1 1/4" Framing System
 Concrete Inserts
 Electrical Fittings
 Pipe/Conduit Supports
 General Fittings
 Nuts & Hardware
 Telesnut System
 Channel
 1 1/2" Channel
 1 3/16" Framing System
 Fiberglass System
 Special Metals
 PrimeAngle System
 Product Index

A1280 END CAP

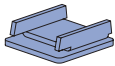

Material: .075" (1.9)
Note: Use with A1000 channel

Wt/100 pcs: 7 Lbs (3.2 kg)

A4280 END CAP



Material: .075" (1.9)
Note: Use with A4000 channel.

Wt/100 pcs: 3 Lbs (1.4 kg)

A5280 END CAP

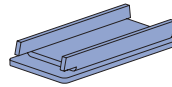

Material: .075" (1.9)
Note: Use with A5000 channel.

Wt/100 pcs: 14 Lbs (6.4 kg)

A1184 CLOSURE STRIP

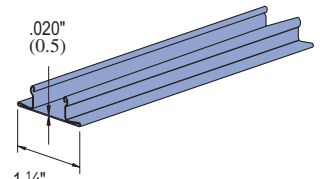

Standard Length 10 Feet
Finish:
Perma-Green II (GR), Plain (PL).

Wt/100 Ft: 21 Lbs (31.3 kg/100M)

A1191

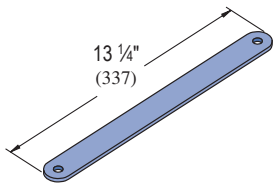

Wt/100 pcs: 87 Lbs (39.5 kg)

A1063

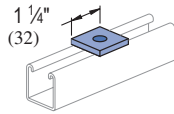

Wt/100 pcs: 8 Lbs (3.6 kg)

A1065

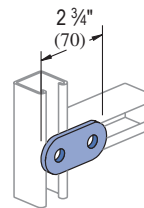

Wt/100 pcs: 17 Lbs (7.7 kg)

A1184P CLOSURE STRIP

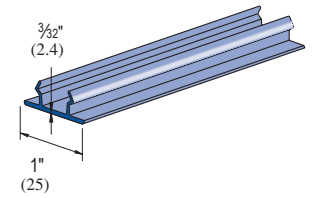

Standard length: 10 Ft.

Material: Paintable PVC.
Color: Green, Grey.

Wt/100 Ft: 21 Lbs (31.3 kg/100M)

A1066

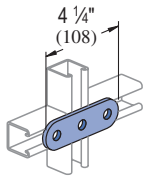

Wt/100 pcs: 26 Lbs (11.8 kg)

A2324

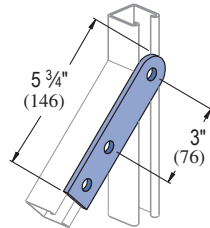

Wt/100 pcs: 39 Lbs (17.7 kg)

A1036

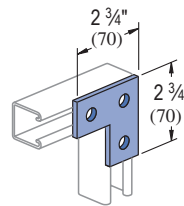

Wt/100 pcs: 27 Lbs (12.2 kg)

A1031

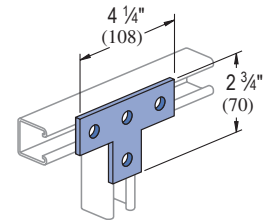

Wt/100 pcs: 34 Lbs (15.4 kg)

A1026

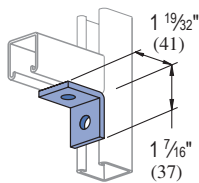

Wt/100 pcs: 17 Lbs (7.7 kg)

A1068

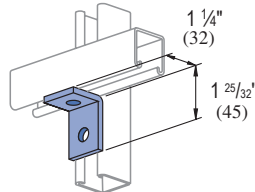

Wt/100 pcs: 17 Lbs (7.7 kg)

A1326

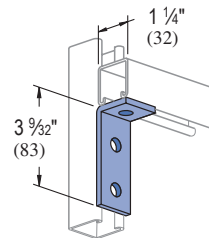

Wt/100 pcs: 27 Lbs (12.2 kg)

A1458

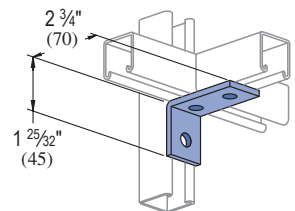

Wt/100 pcs: 27 Lbs (12.2 kg)

Standard Dimensions for 1/4" (32 mm) width series channel fittings (Unless Otherwise Shown on Drawing)

Hole Diameter: 13/32" (10mm); Hole Spacing - From End: 5/8" (16 mm); Hole Spacing - On Center: 1 1/2" (38mm); Width: 1 1/4" (32mm); Thickness: 3/16" (5mm)



A1325

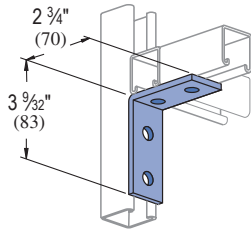

Wt/100 pcs: 38 Lbs (17.2 kg)

A1033

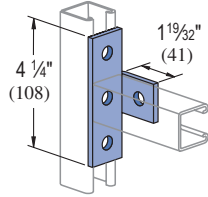

Wt/100 pcs: 34 Lbs (15.4 kg)

A1037

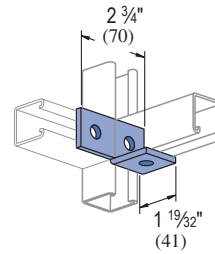

Wt/100 pcs: 30 Lbs (13.6 kg)

A1038

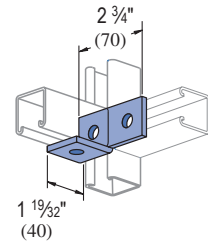

Wt/100 pcs: 30 Lbs (13.6 kg)

A1357

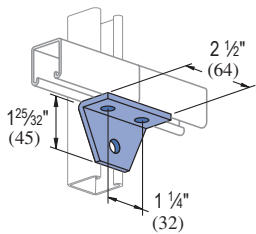

Wt/100 pcs: 30 Lbs (13.6 kg)

A1331

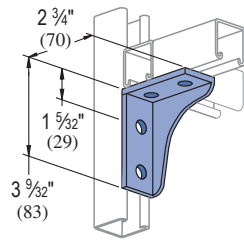

Wt/100 pcs: 75 Lbs (34.0 kg)

A1332

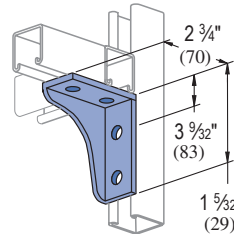

Wt/100 pcs: 75 Lbs (34.0 kg)

A1579

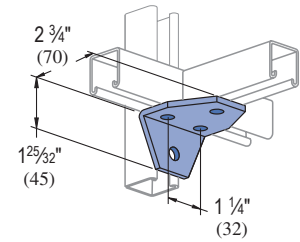

Wt/100 pcs: 44 Lbs (20.0 kg)

A2235

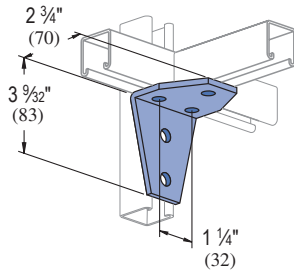

Wt/100 pcs: 59 Lbs (26.8 kg)

A2120

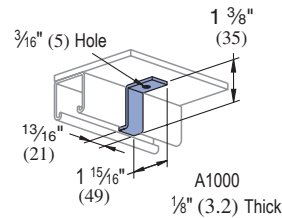

Wt/100 pcs: 9 Lbs (4.1 kg)

A4120

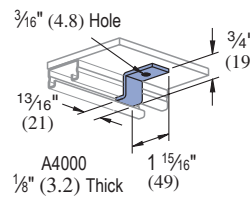

Wt/100 pcs: 7 Lbs (3.2 kg)

A5120

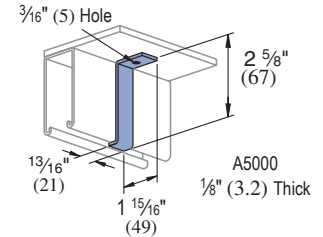

Wt/100 pcs: 13 Lbs (5.9 kg)

A1045

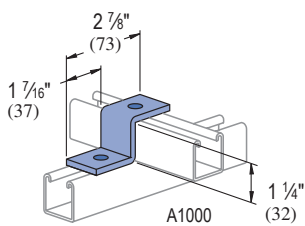

Wt/100 pcs: 25 Lbs (11.3 kg)

A3345

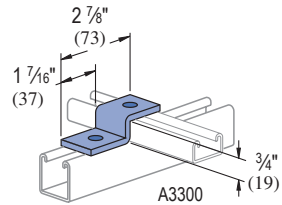

Wt/100 pcs: 23 Lbs (10.4 kg)

A4045

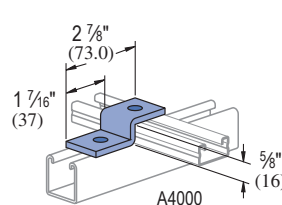

Wt/100 pcs: 21 Lbs (9.5 kg)

A5045

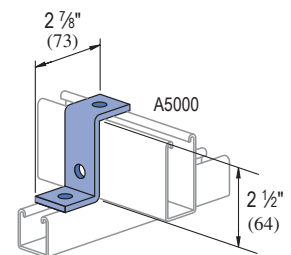

Wt/100 pcs: 33 Lbs (15.0 kg)

Standard Dimensions for 1 1/4" (32 mm) width series channel fittings (Unless Otherwise Shown on Drawing)

Hole Diameter: 13/32" (10mm); **Hole Spacing - From End:** 5/8" (16 mm); **Hole Spacing - On Center:** 1 1/2" (38= mm); **Width:** 1 1/4"(32mm); **Thickness:** 3/16" (5mm)

1 1/2" Channel
 Telestrut System
 Hardware
 General Fittings
 Pipe/Conduit Supports
 Electrical Fittings
 Concrete Inserts
 1 1/4" Framing System
 1 3/16" Framing System
 Fiberglass System
 Special Metals
 PrimeAngle System
 Product Index

A2109, A2110, A2111

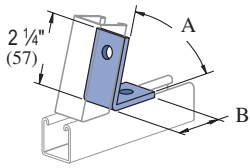

| Part Number | A Degree (rad) | B In (mm) |
|-------------|----------------|---------------------------------------|
| A2109 | 52½° 0.92 | 1 ²⁵ / ₃₂ 45 |
| A2110 | 45° 0.79 | 1¾ 45 |
| A2111 | 37½° 0.65 | 1¾ 45 |

Wt/100 pcs: 23 Lbs (10.4 kg)

A2125, A2126, A2127

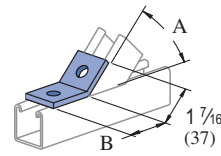

| Part Number | A Degree (rad) | B In (mm) |
|-------------|----------------|--------------------------------------|
| A2125 | 52½° 0.92 | ¼ 32 |
| A2126 | 45° 0.79 | ¼ 32 |
| A2127 | 37½° 0.65 | 1 ⁹ / ₃₂ 33 |

Wt/100 pcs: 17 Lbs (7.7 kg)

A2084

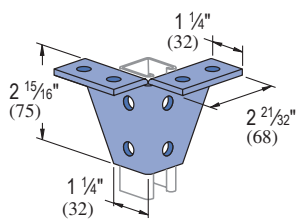

Wt/100 pcs: 90 Lbs (40.8 kg)

A2341 R-L

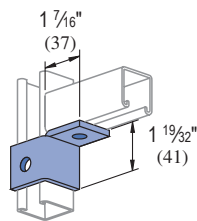

R-As shown
L-Opposite hand

Wt/100 pcs: 26 Lbs (11.8 kg)

A2472 R-L

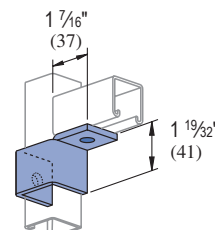

R-As shown
L-Opposite hand

Wt/100 pcs: 33 Lbs (15.0 kg)

A2223

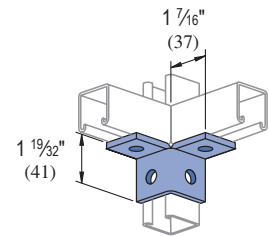

Wt/100 pcs: 34 Lbs (15.4 kg)

A2345

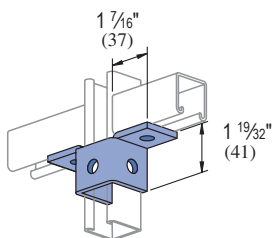

Wt/100 pcs: 41 Lbs (18.6 kg)

A2227

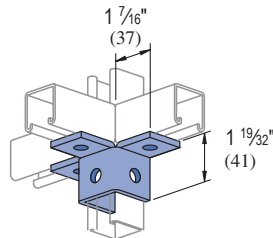

Wt/100 pcs: 52 Lbs (23.6 kg)

A1047

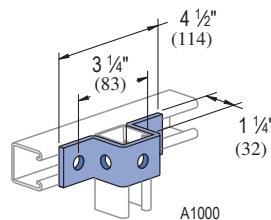

Wt/100 pcs: 43 Lbs (19.5 kg)

A3347

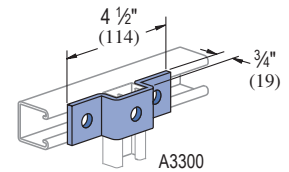

Wt/100 pcs: 37 Lbs (16.8 kg)

A4047

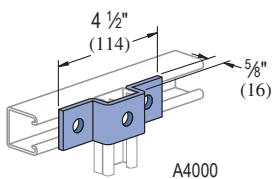

Wt/100 pcs: 34 Lbs (15.4 kg)

A5047

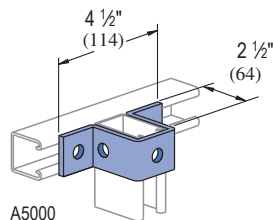

Wt/100 pcs: 58 Lbs (26.3 kg)

A5043

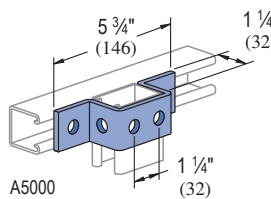

Wt/100 pcs: 50 Lbs (22.7 kg)

Standard Dimensions for 1/4" (32 mm) width series channel fittings (Unless Otherwise Shown on Drawing)

Hole Diameter: 13/32" (10mm); Hole Spacing - From End: 5/8" (16 mm); Hole Spacing - On Center: 1 1/2" (38mm); Width: 1 1/4" (32mm); Thickness: 3/16" (5mm)



A2608 THRU A2617

UNI-CLIP®

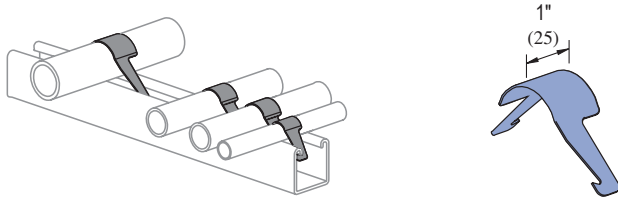

Stainless steel, Type 301.
Patent No. 2863625.

| Part Number | Pipe Size In (mm) | O.D. Size In (mm) | Wt/100 pcs Lbs (kg) |
|-------------|-------------------|-------------------|---------------------|
| A2608 | ¼ | 0.540 | 0.6 |
| A2609 | ⅜ | 0.675 | 0.7 |
| A2611 | ½ | 0.840 | 1.0 |
| A2612 | ¾ | 1.050 | 1.4 |
| A2613 | 1 | 1.315 | 2.0 |
| A2614 | 1¼ | 1.660 | 2.4 |
| A2615 | 1½ | 1.900 | 3.2 |
| A2617 | 2 | 2.375 | 4.7 |
| | 51 | 60.3 | 2.1 |

A2491 R-L, A2492 R-L, A2493 R-L

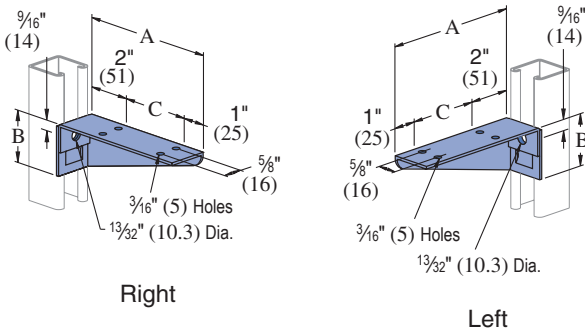

| Part Number | A In (mm) | B In (mm) | C In (mm) | Wt/100 pcs Lbs (kg) |
|-------------|-----------|-----------|-----------|---------------------|
| A2491 R-L | 6 | 2 | 3 | 38 |
| A2492 R-L | 152 | 51 | 76 | 17.2 |
| A2493 R-L | 8 | 2½ | 5 | 56 |
| | 203 | 64 | 126 | 25.4 |
| | 10 | 3 | 7 | 73 |
| | 254 | 76 | 178 | 33.1 |

Design Uniform Load
(Channel Upright Listed)
A1000 200 Lbs (.89 kN)
A4000 130 Lbs (.58 kN)
Safety Factor of 2½

Material: 14 Gauge Steel.

A2494 R-L THRU A2497 R-L

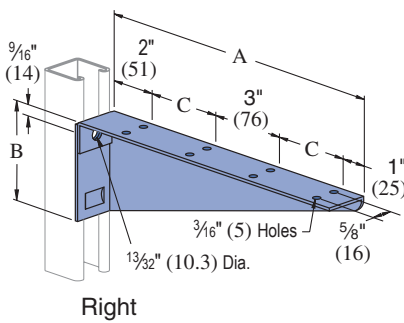

Design Uniform Load
(Channel Upright Listed)
A1000 200 Lbs (.89 kN)
A4000 130 Lbs (.58 kN)
Safety Factor of 2½

| Part Number | A In (mm) | B In (mm) | C In (mm) | Wt/100 pcs Lbs (kg) |
|-------------|-----------|-----------|-----------|---------------------|
| A2494 R-L | 12 | 3½ | 3 | 94 |
| | 305 | 89 | 76 | 42.6 |
| A2495 R-L | 14 | 4 | 4 | 105 |
| | 356 | 102 | 102 | 47.6 |
| A2496 R-L | 16 | 4½ | 5 | 145 |
| | 406 | 114 | 127 | 65.8 |
| A2497 R-L | 18 | 5 | 6 | 175 |
| | 457 | 127 | 152 | 79.4 |

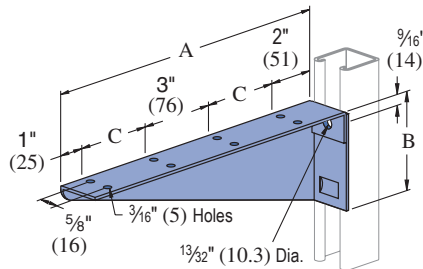

Material: 14 Gauge Steel.

Standard Dimensions for 1¼" (32 mm) width series channel fittings (Unless Otherwise Shown on Drawing)
Hole Diameter: 13/32" (10mm); Hole Spacing - From End: 5/8" (16 mm); Hole Spacing - On Center: 1½" (38= mm); Width: 1¼"(32mm); Thickness: 3/16" (5mm)

15/16" Channel
Telestrut System
Nuts & Hardware
General Fittings
Pipe/Conduit Supports
Electrical Fittings
Concrete Inserts
1¼" Framing System
13/16" Framing System
Fiberglass System
Special Metals
PrimeAngle System
Product Index



1³/₁₆" FRAMING SYSTEM

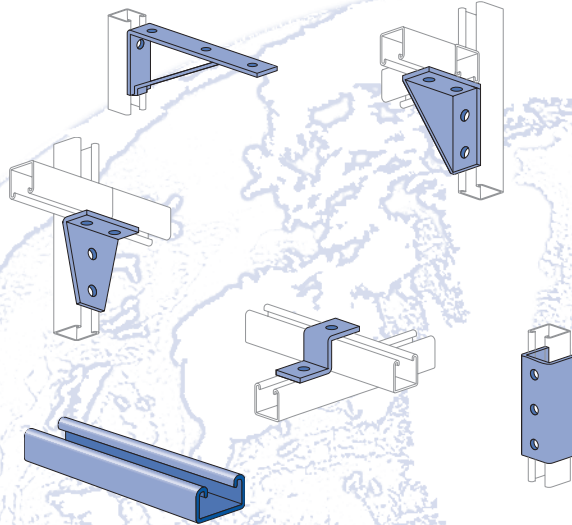

| | |
|---------------------------------------|---------|
| P6000 (19 Gauge) | 157-158 |
| P7000 (19 Gauge) | 159-160 |
| Channel Nuts and Closure Strips | 161 |
| Flat Plate Fittings | 161-162 |
| Ninety Degree Fittings..... | 162 |
| Angular Fittings | 162-164 |
| "Z" Shape Fittings | 164 |
| "U" Shape Fittings | 164-165 |
| Special Application Fittings..... | 165 |
| Beam Clamps..... | 166 |
| Tubing Clips | 166 |

MATERIAL

Channels are accurately and carefully cold formed to size from low-carbon strip steel.

STEEL: PLAIN

19 Gauge (1.0 mm) ASTM A1008

STEEL: PRE-GALVANIZED

19 Gauge (1.0 mm) ASTM A653 GR 33

All nuts are manufactured from mild steel bars conforming to ASTM A1011 SS Grade 33.

Fittings are made from hot rolled, pickled and oiled steel plate or strip and conform to ASTM A1011 SS GR 33.

FINISHES

Channels are available in: Perma-Green III (GR), electro-galvanized (EG), Pre-galvanized (PG), conforming to ASTM A653 GR 33 and plain (PL).

Nuts are available in plain or electro-galvanized (EG) finish.

Fittings are available in Perma-Green III, electrogalvanized (EG) with zinc electrolytically to commercial standards ASTM B653-G90 Type III SC1; or plain (PL).

STANDARD LENGTHS

P-6000 – 16 Feet (4.88m)

P-7000 – 10 Feet (3.05m)

Tolerances are +¹/₈" (3.2 mm) to +¹/₂" (12.7 mm) to allow for cutting. Special lengths are available for a small cutting charge with a tolerance of ±¹/₈" (3.2mm).

APPLICATION

A unique half-size reduction of the 1⁵/₈" channel width series, this smaller channel size can be used to carry light loads economically in applications such as instrumentation, retail displays and light-duty laboratory supports. It also provides the flexibility found in all Unistrut® framing systems.

DESIGN BOLT TORQUE

| BOLT SIZE | 1/4"-20 | Rec. Torque Ft/Lbs (N•m) | 6 (8) | Max Torque Ft/Lbs (N•m) | 7 (9) |
|-----------|---------|-----------------------------|----------|----------------------------|----------|
|-----------|---------|-----------------------------|----------|----------------------------|----------|

DIMENSIONS

Imperial dimensions are illustrated in inches. Metric dimensions are shown in parenthesis or as noted. Unless noted, all metric dimensions are in millimeters and rounded to one decimal place.

LOAD DATA

All beam and column load data pertains to carbon steel and stainless steel channels. Load tables and charts are constructed to be in accordance with the SPECIFICATION FOR THE DESIGN OF COLD-FORMED STEEL STRUCTURAL MEMBERS 2001 EDITION published by the AMERICAN IRON AND STEEL INSTITUTE USING ASD METHOD.

| Type of Load | Safety Factor to Yield Strength | Safety Factor to Ultimate Strength |
|--------------|---------------------------------|------------------------------------|
| Beam Loads | 1.67 | 2.0 |
| Column Load | 1.80 | 2.2 |



P6000 Series

P7000 Series

13/16" x 13/16"
19 Ga.

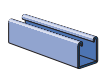

P6000 - Pg 157

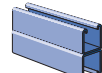

P6001 - Pg 157

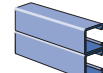

P6001 A - Pg 158

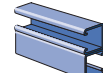

P6001 B - Pg 158

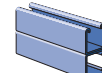

P6001 C - Pg 158

13/16" x 13/32"
19 Ga.

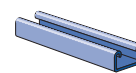

P7000 - Pg 159

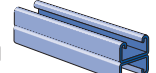

P7001 - Pg 159

Channel Nuts & Closures

13/16" Series Fittings



P6006-0832 - Pg 161



P7006-0832 - Pg 161



P6280 - Pg 161



P7280 - Pg 161

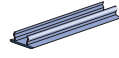

P6184P - Pg 161



P6062 - Pg 161



P6065 - Pg 161



P6924 - Pg 161



P7325 - Pg 161

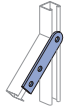

P7324 - Pg 161



P6925 - Pg 161



P6066 - Pg 161



P6067 - Pg 161



P6962 - Pg 161



P6356 A - Pg 161



P6358 A - Pg 161



P6726 A - Pg 162



P6334 - Pg 162



P6380 - Pg 162



P6036 - Pg 162



P6380 A - Pg 162



P6031 - Pg 162



P6028 - Pg 162



P6026 - Pg 162



P6068 - Pg 162



P6281 - Pg 162



P6069 - Pg 162



P6326 - Pg 162

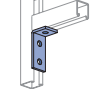

P6346 - Pg 162



P6458 - Pg 162



P6325 - Pg 162



P6033 - Pg 162



P6037 - Pg 163



P6038 - Pg 163



P6357 - Pg 163



P6359 - Pg 163



P6579 - Pg 163



P6728 - Pg 163



P6917 - Pg 163

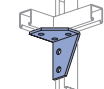

P6918 - Pg 163



P7235 - Pg 163



P6130 - Pg 163



P6290 - Pg 163



P6291 - Pg 163



P6381 - Pg 163



P6382 - Pg 163



P6887 - Pg 163



P6331 - Pg 163



P6332 - Pg 164



P6546 - Pg 164



P6186 - Pg 164

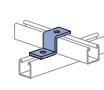

P6045 - Pg 164



P7045 - Pg 164



P6347 - Pg 164



P7347 - Pg 164



P6453 - Pg 164



P6454 - Pg 164



P6758 - Pg 164



P7758 - Pg 164



P6047 - Pg 164



P6737 - Pg 164



P6048 - Pg 164

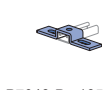

P7048 - Pg 165



P6376 - Pg 165



P7376 - Pg 165



P6376 A - Pg 165



P7376 A - Pg 165



P6377 - Pg 165



P7377 - Pg 165



P6044 - Pg 165



P6455 - Pg 165



P6973 - Pg 165



P6349 - Pg 165



P6353 - Pg 165



P6127 - Pg 165



P6379 S - Pg 166



P6386 - Pg 166



P6805 - Pg 166



P7008 - Pg 166

15/16" Channel
 Telesruct System
 Nuts & Hardware
 General Fittings
 Pipe/Conduit Supports
 Electrical Fittings
 Concrete Inserts
 1 1/4" Framing System
 13/16" Framing System
 Fiberglass System
 Special Metals
 PrimeAngle System
 Product Index

P6000

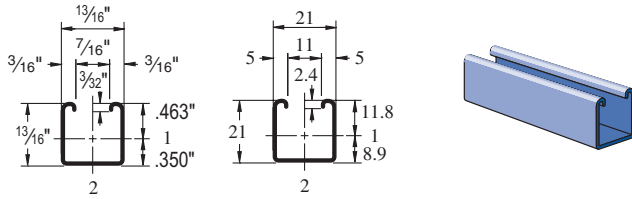

Wt/100 Ft: 36 Lbs (54 kg/100 m)
 Allowable Moment 510 In-Lbs (60 N*m)
 19 Gauge Nominal Thickness .040" (1.0 mm)

P6001

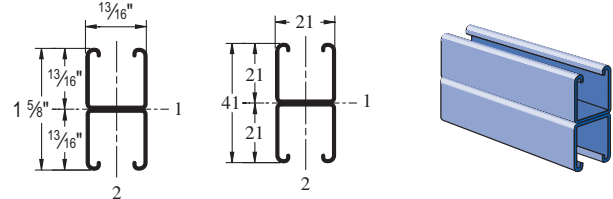

Wt/100 Ft: 73 Lbs (108 kg/100 m)
 Allowable Moment 1,390 In-Lbs (160 N*m)
 19 Gauge Nominal Thickness .040" (1.0 mm)

P6000 - BEAM LOADING

| Span In | Max Allowable Uniform Load Lbs | Defl. at Uniform Load In | Uniform Loading at Deflection | | |
|---------|--------------------------------|--------------------------|-------------------------------|--------------|--------------|
| | | | Span/180 Lbs | Span/240 Lbs | Span/360 Lbs |
| 18 | 230 | 0.06 | 230 | 230 | 180 |
| 24 | 170 | 0.11 | 170 | 150 | 100 |
| 30 | 140 | 0.18 | 130 | 100 | 70 |
| 36 | 110 | 0.24 | 90 | 70 | 50 |
| 42 | 100 | 0.35 | 70 | 50 | 30 |
| 48 | 80 | 0.42 | 50 | 40 | 30 |
| 54 | 80 | 0.60 | 40 | 30 | 20 |
| 60 | 70 | 0.72 | 30 | 20 | 20 |
| 66 | 60 | 0.82 | 30 | 20 | 10 |
| 72 | 60 | 1.06 | 20 | 20 | 10 |

P6001 - BEAM LOADING

| Span In | Max Allowable Uniform Load Lbs | Defl. at Uniform Load In | Uniform Loading at Deflection | | |
|---------|--------------------------------|--------------------------|-------------------------------|--------------|--------------|
| | | | Span/180 Lbs | Span/240 Lbs | Span/360 Lbs |
| 18 | 620 | 0.04 | 620 | 620 | 620 |
| 24 | 460 | 0.06 | 460 | 460 | 460 |
| 30 | 370 | 0.10 | 370 | 370 | 320 |
| 36 | 310 | 0.14 | 310 | 310 | 220 |
| 42 | 270 | 0.20 | 270 | 240 | 160 |
| 48 | 230 | 0.25 | 230 | 180 | 120 |
| 54 | 210 | 0.32 | 190 | 150 | 100 |
| 60 | 190 | 0.40 | 160 | 120 | 80 |
| 66 | 170 | 0.48 | 130 | 100 | 70 |
| 72 | 150 | 0.55 | 110 | 80 | 50 |

P6000 - COLUMN LOADING

| Unbraced Height In | Maximum Allowable Load at Slot Face Lbs | Maximum Column Load Applied at C.G. | | | |
|--------------------|---|-------------------------------------|--------------|-------------|-------------|
| | | K = 0.65 Lbs | K = 0.80 Lbs | K = 1.0 Lbs | K = 1.2 Lbs |
| 18 | 600 | 1,660 | 1,400 | 1,100 | 860 |
| 24 | 490 | 1,300 | 1,010 | 740 | 590 |
| 30 | 420 | 990 | 740 | 560 | 450 |
| 36 | 340 | 770 | 590 | 450 | 370 |
| 42 | 300 | 630 | 490 | 380 | 310 |
| 48 | 260 | 540 | 420 | 330 | 270 |
| 54 | 240 | 470 | 370 | 290 | ** |
| 60 | 210 | 410 | 330 | ** | ** |
| 66 | 210 | 370 | 300 | ** | ** |
| 72 | 180 | 340 | 270 | ** | ** |

P6001 - COLUMN LOADING

| Unbraced Height In | Maximum Allowable Load at Slot Face Lbs | Maximum Column Load Applied at C.G. | | | |
|--------------------|---|-------------------------------------|--------------|-------------|-------------|
| | | K = 0.65 Lbs | K = 0.80 Lbs | K = 1.0 Lbs | K = 1.2 Lbs |
| 18 | 1,210 | 4,320 | 4,080 | 3,770 | 3,500 |
| 24 | 1,170 | 3,980 | 3,680 | 3,330 | 3,060 |
| 30 | 1,130 | 3,650 | 3,330 | 3,000 | 2,460 |
| 36 | 1,070 | 3,370 | 3,060 | 2,460 | 1,800 |
| 42 | 1,020 | 3,140 | 2,690 | 1,900 | 1,320 |
| 48 | 900 | 2,930 | 2,230 | 1,460 | 1,010 |
| 54 | 820 | 2,550 | 1,800 | 1,150 | 800 |
| 60 | 700 | 2,180 | 1,460 | 930 | ** |
| 66 | 700 | 1,830 | 1,210 | 770 | ** |
| 72 | 550 | 1,530 | 1,010 | ** | ** |

P6000 & P6001 - ELEMENTS OF SECTION

| Parameter | P6000 | | P6001 | |
|------------------------|-------|-----------------|-------|-----------------|
| Area of Section | 0.107 | in ² | 0.213 | in ² |
| Axis 1-1 | | | | |
| Moment of Inertia (I) | 0.009 | in ⁴ | 0.045 | in ⁴ |
| Section Modulus (S) | 0.020 | in ³ | 0.055 | in ³ |
| Radius of Gyration (r) | 0.295 | in | 0.460 | in |
| Axis 2-2 | | | | |
| Moment of Inertia (I) | 0.012 | in ⁴ | 0.024 | in ⁴ |
| Section Modulus (S) | 0.029 | in ³ | 0.058 | in ³ |
| Radius of Gyration (r) | 0.333 | in | 0.333 | in |

Notes:

* Load limited by spot weld shear.

** $KL/r > 200$

NR = Not Recommended.

- Above loads include the weight of the member. This weight must be deducted to arrive at the net allowable load the beam will support.
- Long span beams should be supported in such a manner as to prevent rotation and twist.
- Allowable uniformly distributed loads are listed for various simple spans, that is, a beam on two supports. If load is concentrated at the center of the span, multiply load from the table by 0.5 and corresponding deflection by 0.8.



P6000 - BEAM LOADING (METRIC)

| Span mm | Max Allowable Uniform Load kN | Defl. at Uniform Load mm | Uniform Loading at Deflection | | |
|------------|--|-----------------------------------|-------------------------------|----------------|----------------|
| | | | Span/180 kN | Span/240 kN | Span/360 kN |
| 300 | 1.5 | 1 | 1.5 | 1.5 | 1.5 |
| 450 | 1.0 | 2 | 1.0 | 1.0 | 0.8 |
| 600 | 0.8 | 3 | 0.8 | 0.7 | 0.5 |
| 750 | 0.6 | 4 | 0.6 | 0.4 | 0.3 |
| 1,000 | 0.4 | 7 | 0.4 | 0.3 | 0.2 |
| 1,250 | 0.4 | 11 | 0.2 | 0.2 | 0.1 |
| 1,500 | 0.3 | 17 | 0.1 | 0.1 | 0.1 |
| 1,750 | 0.3 | 24 | 0.1 | 0.1 | 0.0 |

P6001 - BEAM LOADING (METRIC)

| Span mm | Max Allowable Uniform Load kN | Defl. at Uniform Load mm | Uniform Loading at Deflection | | |
|------------|--|-----------------------------------|-------------------------------|----------------|----------------|
| | | | Span/180 kN | Span/240 kN | Span/360 kN |
| 300 | 2.9* | 0 | 2.9* | 2.9* | 2.9* |
| 450 | 2.8 | 1 | 2.8 | 2.8 | 2.8 |
| 600 | 2.1 | 2 | 2.1 | 2.1 | 2.1 |
| 750 | 1.7 | 2 | 1.7 | 1.7 | 1.5 |
| 1,000 | 1.2 | 4 | 1.2 | 1.2 | 0.8 |
| 1,250 | 1.0 | 7 | 1.0 | 0.8 | 0.5 |
| 1,500 | 0.8 | 10 | 0.7 | 0.5 | 0.4 |
| 1,750 | 0.7 | 13 | 0.5 | 0.4 | 0.3 |
| 2,000 | 0.6 | 17 | 0.4 | 0.3 | 0.2 |

P6000 - COLUMN LOADING (METRIC)

| Unbraced Height mm | Maximum Allowable Load at Slot Face kN | Maximum Column Load Applied at C.G. | | | |
|--------------------------|--|-------------------------------------|----------------|---------------|---------------|
| | | K = 0.65 kN | K = 0.80 kN | K = 1.0 kN | K = 1.2 kN |
| 300 | 3.1 | 9.2 | 8.4 | 7.3 | 6.3 |
| 450 | 2.7 | 7.5 | 6.3 | 5.0 | 3.9 |
| 600 | 2.2 | 5.9 | 4.6 | 3.4 | 2.7 |
| 750 | 1.8 | 4.5 | 3.4 | 2.5 | 2.0 |
| 1,000 | 1.4 | 3.0 | 2.4 | 1.8 | 1.5 |
| 1,250 | 1.1 | 2.3 | 1.8 | 1.4 | 1.2 |
| 1,500 | 0.9 | 1.9 | 1.5 | 1.2 | ** |
| 1,750 | 0.8 | 1.6 | 1.2 | ** | ** |

P6001 - COLUMN LOADING (METRIC)

| Unbraced Height mm | Maximum Allowable Load at Slot Face kN | Maximum Column Load Applied at C.G. | | | |
|--------------------------|--|-------------------------------------|----------------|---------------|---------------|
| | | K = 0.65 kgN | K = 0.80 kN | K = 1.0 kN | K = 1.2 kN |
| 300 | 5.5 | 20.7 | 20.1 | 19.2 | 18.2 |
| 450 | 5.4 | 19.3 | 18.2 | 16.9 | 15.7 |
| 600 | 5.2 | 17.8 | 16.5 | 14.9 | 13.7 |
| 750 | 5.0 | 16.4 | 14.9 | 13.5 | 11.2 |
| 1,000 | 4.6 | 14.4 | 12.9 | 9.5 | 6.7 |
| 1,250 | 3.9 | 12.7 | 9.5 | 6.2 | 4.3 |
| 1,500 | 3.2 | 9.9 | 6.7 | 4.3 | ** |
| 1,750 | 2.6 | 7.5 | 4.9 | ** | ** |
| 2,000 | 2.2 | 5.7 | 3.8 | ** | ** |

P6000 & P6001 - ELEMENTS OF SECTION (METRIC)

| Parameter | P6000 | P6001 |
|------------------------|----------------------|----------------------|
| Area of Section | 0.69 cm ² | 1.38 cm ² |
| Axis 1-1 | | |
| Moment of Inertia (I) | 0.39 cm ⁴ | 1.88 cm ⁴ |
| Section Modulus (S) | 0.33 cm ³ | 0.91 cm ³ |
| Radius of Gyration (r) | 0.75 cm | 1.17 cm |
| Axis 2-2 | | |
| Moment of Inertia (I) | 0.49 cm ⁴ | 0.99 cm ⁴ |
| Section Modulus (S) | 0.48 cm ³ | 0.96 cm ³ |
| Radius of Gyration (r) | 0.85 cm | 0.85 cm |

Notes:

* Load limited by spot weld shear.

** $KL_r > 200$

NR = Not Recommended.

- Above loads include the weight of the member. This weight must be deducted to arrive at the net allowable load the beam will support.
- Long span beams should be supported in such a manner as to prevent rotation and twist.
- Allowable uniformly distributed loads are listed for various simple spans, that is, a beam on two supports. If load is concentrated at the center of the span, multiply load from the table by 0.5 and corresponding deflection by 0.8.

P6001A

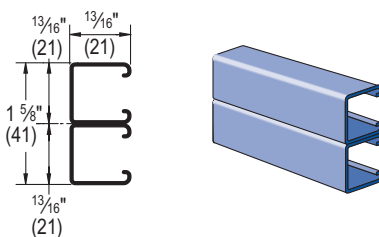

Wt/100 Ft: 73 Lbs (108 kg/100 m)
 Allowable Moment 1,820 In-Lbs (210 N*m)
 19 Gauge Nominal Thickness .040" (1.0 mm)

P6001B

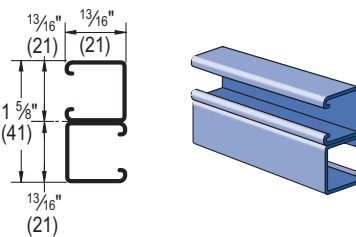

Wt/100 Ft: 73 Lbs (108 kg/100 m)
 Allowable Moment 1,820 In-Lbs (210 N*m)
 19 Gauge Nominal Thickness .040" (1.0 mm)

P6001C

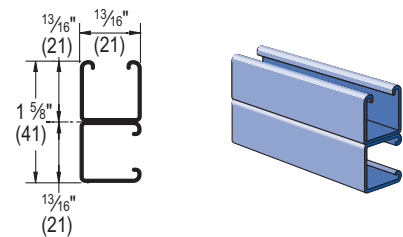

Wt/100 Ft: 73 Lbs (108 kg/100 m)
 Allowable Moment 1,550 In-Lbs (180 N*m)
 19 Gauge Nominal Thickness .040" (1.0 mm)

1 3/16" Channel
 Telesstrut System
 Hardware
 General Fittings
 Pipe/Conduit Supports
 Electrical Fittings
 Concrete Inserts
 1 1/4" Framing System
 1 3/16" Framing System
 Fiberglass System
 Special Metals
 PrimeAngle System
 Product Index

P7000

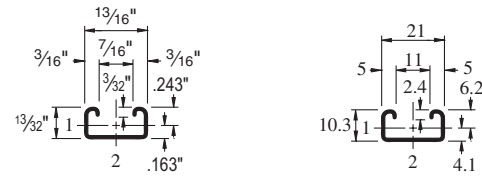
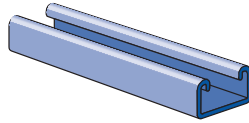

Wt/100 Ft: 25 Lbs (38 kg/100m)
 Allowable Moment 170 In-Lbs (20 N·m)
 19 Gauge Nominal Thickness .040" (1.0 mm)

P7001

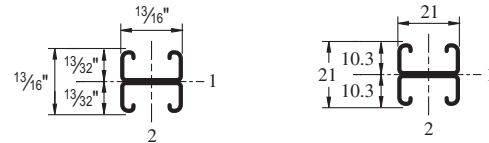
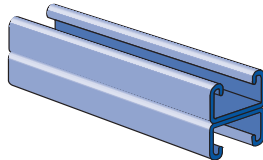

Wt/100 Ft: 50 Lbs (75 kg/100m)
 Allowable Moment 450 In-Lbs (50 N·m)
 19 Gauge Nominal Thickness .040" (1.0 mm)

P7000 - BEAM LOADING

| Span In | Max Allowable Uniform Load Lbs | Defl. at Uniform Load In | Uniform Loading at Deflection | | |
|---------|--------------------------------|--------------------------|-------------------------------|--------------|--------------|
| | | | Span/180 Lbs | Span/240 Lbs | Span/360 Lbs |
| 18 | 80 | 0.12 | 60 | 50 | 30 |
| 24 | 60 | 0.22 | 40 | 30 | 20 |
| 30 | 50 | 0.36 | 20 | 20 | 10 |
| 36 | 40 | 0.50 | 20 | 10 | 10 |

P7001 - BEAM LOADING

| Span In | Max Allowable Uniform Load Lbs | Defl. at Uniform Load In | Uniform Loading at Deflection | | |
|---------|--------------------------------|--------------------------|-------------------------------|--------------|--------------|
| | | | Span/180 Lbs | Span/240 Lbs | Span/360 Lbs |
| 18 | 200 | 0.07 | 200 | 200 | 140 |
| 24 | 150 | 0.12 | 150 | 120 | 80 |
| 30 | 120 | 0.19 | 100 | 80 | 50 |
| 36 | 100 | 0.28 | 70 | 50 | 40 |
| 42 | 90 | 0.40 | 50 | 40 | 30 |
| 48 | 80 | 0.53 | 40 | 30 | 20 |

P7000 - COLUMN LOADING

| Unbraced Height In | Maximum Allowable Load at Slot Face Lbs | Maximum Column Load Applied at C.G. | | | |
|--------------------|---|-------------------------------------|--------------|-------------|-------------|
| | | K = 0.65 Lbs | K = 0.80 Lbs | K = 1.0 Lbs | K = 1.2 Lbs |
| 18 | 420 | 1,200 | 990 | 720 | 510 |
| 24 | 330 | 900 | 640 | 410 | 280 |
| 30 | 260 | 620 | 410 | ** | ** |
| 36 | 200 | 430 | 280 | ** | ** |

P7001 - COLUMN LOADING

| Unbraced Height In | Maximum Allowable Load at Slot Face Lbs | Maximum Column Load Applied at C.G. | | | |
|--------------------|---|-------------------------------------|--------------|-------------|-------------|
| | | K = 0.65 Lbs | K = 0.80 Lbs | K = 1.0 Lbs | K = 1.2 Lbs |
| 18 | 790 | 2,930 | 2,690 | 2,330 | 1,960 |
| 24 | 740 | 2,570 | 2,210 | 1,720 | 1,260 |
| 30 | 680 | 2,180 | 1,720 | 1,160 | 800 |
| 36 | 580 | 1,780 | 1,260 | 800 | 560 |
| 42 | 500 | 1,400 | 920 | 590 | ** |
| 48 | 420 | 1,070 | 710 | ** | ** |
| 54 | 360 | 850 | 560 | ** | ** |

P7000 & P7001 - ELEMENTS OF SECTION

| Parameter | P7000 | | P7001 | |
|------------------------|-------|-----------------|-------|-----------------|
| Area of Section | 0.074 | In ² | 0.148 | In ² |
| Axis 1-1 | | | | |
| Moment of Inertia (I) | 0.002 | In ⁴ | 0.007 | In ⁴ |
| Section Modulus (S) | 0.007 | In ³ | 0.018 | In ³ |
| Radius of Gyration (r) | 0.150 | In | 0.222 | In |
| Axis 2-2 | | | | |
| Moment of Inertia (I) | 0.007 | In ⁴ | 0.014 | In ⁴ |
| Section Modulus (S) | 0.017 | In ³ | 0.034 | In ³ |
| Radius of Gyration (r) | 0.307 | In | 0.307 | In |

Notes:

** $KL_i > 20$

- Above loads include the weight of the member. This weight must be deducted to arrive at the net allowable load the beam will support.
- Long span beams should be supported in such a manner as to prevent rotation and twist.
- Allowable uniformly distributed loads are listed for various simple spans, that is, a beam on two supports. If load is concentrated at the center of the span, multiply load from the table by 0.5 and corresponding deflection by 0.8.



P7000 - BEAM LOADING (METRIC)

| Span mm | Max Allowable Uniform Load kN | Defl. at Uniform Load mm | Uniform Loading at Deflection | | |
|------------|--|-----------------------------------|-------------------------------|----------------|----------------|
| | | | Span/180 kN | Span/240 kN | Span/360 kN |
| 300 | 0.5 | 1 | 0.5 | 0.5 | 0.4 |
| 450 | 0.4 | 3 | 0.3 | 0.2 | 0.1 |
| 600 | 0.3 | 5 | 0.2 | 0.1 | 0.1 |
| 750 | 0.2 | 9 | 0.1 | 0.1 | 0.0 |
| 1,000 | 0.2 | 16 | 0.0 | 0.0 | 0.0 |
| 1,250 | 0.1 | 24 | 0.0 | 0.0 | NR |
| 1,500 | 0.1 | 28 | 0.0 | NR | NR |

P7001 - BEAM LOADING (METRIC)

| Span mm | Max Allowable Uniform Load kN | Defl. at Uniform Load mm | Uniform Loading at Deflection | | |
|------------|--|-----------------------------------|-------------------------------|----------------|----------------|
| | | | Span/180 kN | Span/240 kN | Span/360 kN |
| 300 | 1.4 | 1 | 1.4 | 1.4 | 1.4 |
| 450 | 0.9 | 2 | 0.9 | 0.9 | 0.7 |
| 600 | 0.7 | 3 | 0.7 | 0.5 | 0.4 |
| 750 | 0.5 | 5 | 0.5 | 0.4 | 0.2 |
| 1,000 | 0.4 | 8 | 0.3 | 0.2 | 0.1 |
| 1,250 | 0.3 | 13 | 0.2 | 0.1 | 0.1 |
| 1,500 | 0.3 | 19 | 0.1 | 0.1 | NR |

P7000 - COLUMN LOADING (METRIC)

| Unbraced Height mm | Maximum Allowable Load at Slot Face kN | Maximum Column Load Applied at C.G. | | | |
|--------------------------|--|-------------------------------------|----------------|---------------|---------------|
| | | K = 0.65 kN | K = 0.80 kN | K = 1.0 kN | K = 1.2 kN |
| 300 | 2.1 | 6.4 | 6.0 | 5.3 | 4.5 |
| 450 | 1.9 | 5.4 | 4.5 | 3.3 | 2.3 |
| 600 | 1.5 | 4.1 | 2.9 | 1.9 | 1.3 |
| 750 | 1.2 | 2.8 | 1.9 | 1.2 | ** |

P7001 - COLUMN LOADING (METRIC)

| Unbraced Height mm | Maximum Allowable Load at Slot Face kN | Maximum Column Load Applied at C.G. | | | |
|--------------------------|--|-------------------------------------|----------------|---------------|---------------|
| | | K = 0.65 kN | K = 0.80 kN | K = 1.0 kN | K = 1.2 kN |
| 300 | 3.6 | 14.0 | 13.6 | 13.0 | 12.1 |
| 450 | 3.5 | 13.1 | 12.1 | 10.5 | 8.9 |
| 600 | 3.3 | 11.6 | 10.0 | 7.8 | 5.8 |
| 750 | 3.0 | 9.8 | 7.8 | 5.3 | 3.7 |
| 1,000 | 2.4 | 6.9 | 4.7 | 3.0 | ** |
| 1,250 | 1.8 | 4.5 | 3.0 | ** | ** |

P7000 & P7001 - ELEMENTS OF SECTION (METRIC)

| Parameter | P7000 | | P7001 | |
|------------------------|-------|-----------------|-------|-----------------|
| Area of Section | 0.48 | cm ² | 0.96 | cm ² |
| Axis 1-1 | | | | |
| Moment of Inertia (I) | 0.07 | cm ⁴ | 0.31 | cm ⁴ |
| Section Modulus (S) | 0.11 | cm ³ | 0.30 | cm ³ |
| Radius of Gyration (r) | 0.38 | cm | 0.57 | cm |
| Axis 2-2 | | | | |
| Moment of Inertia (I) | 0.29 | cm ⁴ | 0.58 | cm ⁴ |
| Section Modulus (S) | 0.28 | cm ³ | 0.56 | cm ³ |
| Radius of Gyration (r) | 0.78 | cm | 0.78 | cm |

Notes:

** $K_L/r > 200$

NR = Not Recommended.

- Above loads include the weight of the member. This weight must be deducted to arrive at the net allowable load the beam will support.
- Long span beams should be supported in such a manner as to prevent rotation and twist.
- Allowable uniformly distributed loads are listed for various simple spans, that is, a beam on two supports. If load is concentrated at the center of the span, multiply load from the table by 0.5 and corresponding deflection by 0.8.

BEARING LOADS ON UNISTRUT CHANNEL

| Channel | Bearing Length ¹³ / ₁₆ " (21 mm) Maximum Allowable Loads - Lbs (kN) | Bearing Length ¹³ / ₁₆ " (21 mm) Maximum Allowable Loads - Lbs (kN) | Bearing Length ¹ / ₂ " (41 mm) Maximum Allowable Loads - Lbs (kN) |
|---------|--|--|--|
| P6000 | 1,000 (4.45) | 500 (2.22) | 1,200 (5.34) |
| P7000 | 1,000 (4.45) | 500 (2.22) | 1,200 (5.34) |

MAXIMUM ALLOWABLE PULL-OUT AND SLIP LOADS

| Nut Size/ Thread | Max. Allowable Pull-Out Lbs (kN) | Resistance to Slip Lbs (kN) | Torque Ft-Lbs (N·m) |
|----------------------------------|--|-----------------------------------|------------------------|
| ¹ / ₄ "-20 | 250 1.11 | 150 0.67 | 6 8 |

15/16" Channel
 Telesruct System
 Nuts & Hardware
 General Fittings
 Pipe/Conduit Supports
 Electrical Fittings
 Concrete Inserts
 1 1/4" Framing System
 1 3/16" Framing System
 Fiberglass System
 Special Metals
 PrimeAngle System
 Product Index

P6006-0832 THRU P6006-1420
CHANNEL NUT W/SPRING



| Part Number | Thread Size In | Wt/100 pcs Lbs (kg) |
|-------------|----------------|---------------------|
| P6006-0836 | #8 - 36 | 1 (0.5) |
| P6006-0832 | #8 - 32 | 1 (0.5) |
| P6006-1032 | #10 - 32 | 1 (0.5) |
| P6006-1024 | #10 - 24 | 1 (0.5) |
| P6006-1420 | 1/4" - 20 | 1 (0.5) |

P6184 P - CLOSURE STRIP

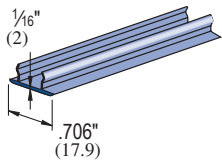

Material: PVC, Plastic.
Standard Length: 10 Feet (3.05 m).

Wt/100 Ft: 4 Lbs (6.0 kg/100m)

P7325

P7006-0832 THRU P7006-1420
CHANNEL NUT W/SPRING



| Part Number | Thread Size In | Wt/100 pcs Lbs (kg) |
|-------------|----------------|---------------------|
| P7006-0836 | #8 - 36 | 1 (0.5) |
| P7006-0832 | #8 - 32 | 1 (0.5) |
| P7006-1032 | #10 - 32 | 1 (0.5) |
| P7006-1024 | #10 - 24 | 1 (0.5) |
| P7006-1420 | 1/4" - 20 | 1 (0.5) |

P6062

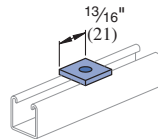

Wt/100 pcs: 2 Lbs (0.9 kg)

P7324

P6280 - END CAP FOR P6000

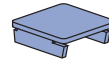

Material: .060" (1.5)

Wt/100 pcs: 3 Lbs (1.4 kg)

P6065

P7280 - END CAP FOR P7000

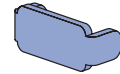

Material: .048" (1.2)

Wt/100 pcs: 1 Lbs (0.5 kg)

P6924

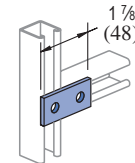

Wt/100 pcs: 5 Lbs (2.3 kg)

P6925

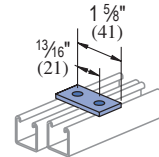

Wt/100 pcs: 5 Lbs (2.3 kg)

P6066

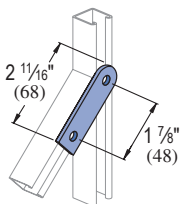

Wt/100 pcs: 7 Lbs (3.2 kg)

P6067

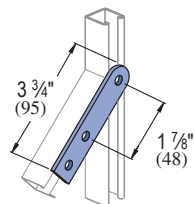

Wt/100 pcs: 10 Lbs (4.5 kg)

P6962

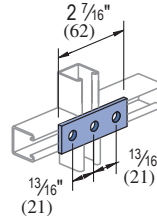

Wt/100 pcs: 7 Lbs (3.2 kg)

P6356A

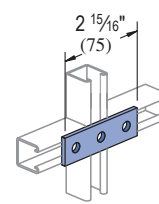

Wt/100 pcs: 8 Lbs (3.6 kg)

P6358A

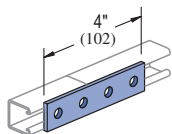

Wt/100 pcs: 11 Lbs (5.0 kg)

P6068

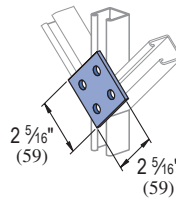

Wt/100 pcs: 19 Lbs (8.6 kg)

P6069

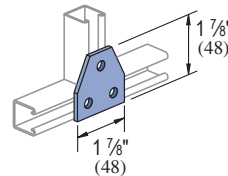

Wt/100 pcs: 10 Lbs (4.5 kg)

P6070

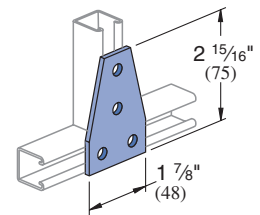

Wt/100 pcs: 15 Lbs (6.8 kg)

P6071

Standard Dimensions for 13/16" (21mm) width series channel fittings (Unless Otherwise Shown on Drawing)

Hole Diameter: 9/32" (7mm); Hole Spacing - From End: 13/32" (10mm); Hole Spacing - On Center: 1 1/16" (27mm); Width: 13/16" (21mm); Thickness: 1/8" (3mm)



P6726A

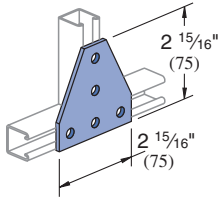

Wt/100 pcs: 22 Lbs (10.0 kg)

P6334

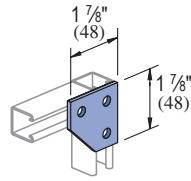

Wt/100 pcs: 11 Lbs (5.0 kg)

P6380

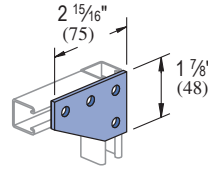

Wt/100 pcs: 15 Lbs (6.8 kg)

P6036

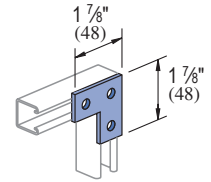

Wt/100 pcs: 8 Lbs (3.6 kg)

P6380A

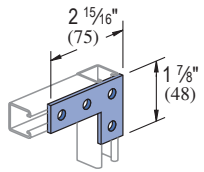

Wt/100 pcs: 11 Lbs (5.0 kg)

P6031

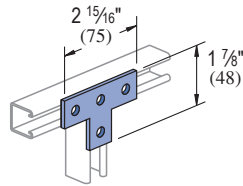

Wt/100 pcs: 11 Lbs (5.0 kg)

P6028

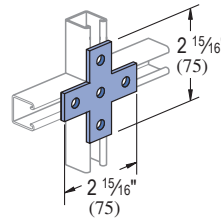

Wt/100 pcs: 14 Lbs (6.4 kg)

P6026

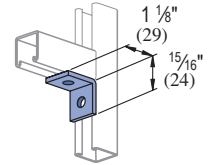

Wt/100 pcs: 5 Lbs (2.3 kg)

P6068

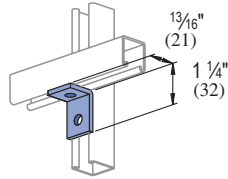

Wt/100 pcs: 5 Lbs (2.3 kg)

P6281, P6282, P6283

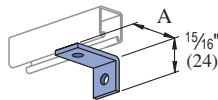

| Part Number | A In (mm) | Wt/100 pcs Lbs (kg) |
|-------------|--------------|------------------------|
| P6281 | 2 | 8 |
| P6282 | 2½ | 9 |
| P6283 | 3 | 10 |
| | 76 | 4.5 |

P6069

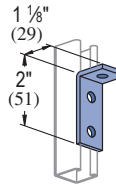

Wt/100 pcs: 8 Lbs (3.6 kg)

P6326

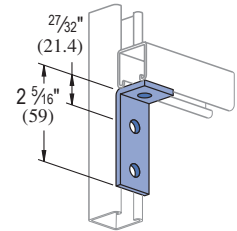

Wt/100 pcs: 8 Lbs (3.6 kg)

P6346

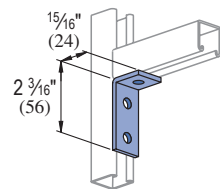

Wt/100 pcs: 8 Lbs (3.6 kg)

P6458

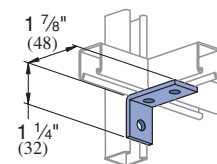

Wt/100 pcs: 8 Lbs (3.6 kg)

P6325

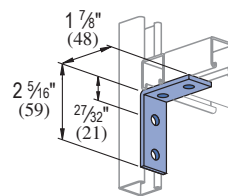

Wt/100 pcs: 11 Lbs (5.0 kg)

P6033

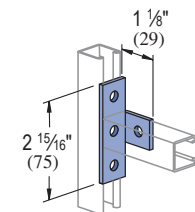

Wt/100 pcs: 11 Lbs (5.0 kg)

Standard Dimensions for 13/16" (21mm) width series channel fittings (Unless Otherwise Shown on Drawing)

Hole Diameter: 9/32" (7mm); Hole Spacing - From End: 13/32" (10mm); Hole Spacing - On Center: 1 1/16" (27mm); Width: 13/16" (21mm); Thickness: 1/8" (3mm)

15/16" Channel
 Telesrnut System
 Nuts & Hardware
 General Fittings
 Pipe/Conduit Supports
 Electrical Fittings
 Concrete Inserts
 1/4" Framing System
 13/16" Framing System
 Fiberglass System
 Special Metals
 PrimeAngle System
 Product Index

P6037

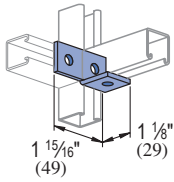

Wt/100 pcs: 8 Lbs (3.6 kg)

P6038

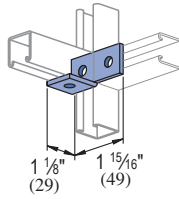

Wt/100 pcs: 8 Lbs (3.6 kg)

P6357

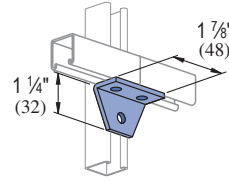

Wt/100 pcs: 10 Lbs (4.5 kg)

P6359

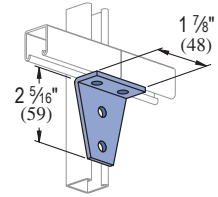

Wt/100 pcs: 15 Lbs (6.8 kg)

P6579

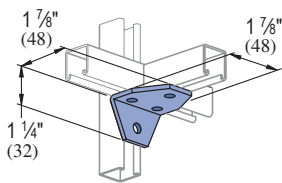

Wt/100 pcs: 15 Lbs (6.8 kg)

P6728

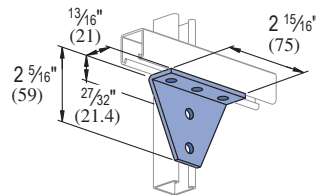

Wt/100 pcs: 22 Lbs (10.0 kg)

P6917

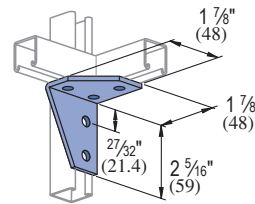

Wt/100 pcs: 21 Lbs (9.5 kg)

P6918

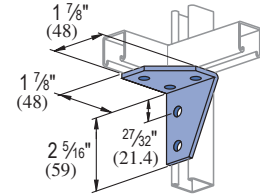

Wt/100 pcs: 21 Lbs (9.5 kg)

P7235

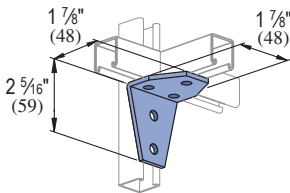

Wt/100 pcs: 18 Lbs (8.2 kg)

P6130

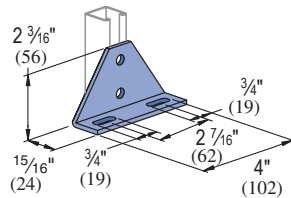

Wt/100 pcs: 32 Lbs (14.5 kg)

P6290

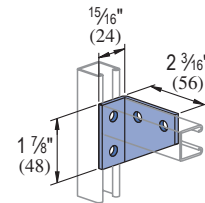

Wt/100 pcs: 15 Lbs (6.8 kg)

P6291

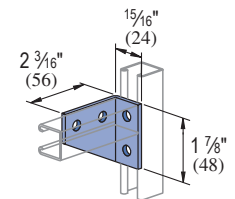

Wt/100 pcs: 15 Lbs (6.8 kg)

P6381

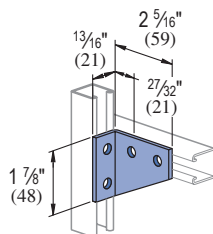

Wt/100 pcs: 15 Lbs (6.8 kg)

P6382

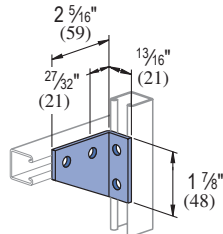

Wt/100 pcs: 15 Lbs (6.8 kg)

P6887

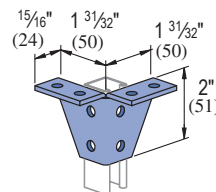

Wt/100 pcs: 28 Lbs (12.7 kg)

P6331

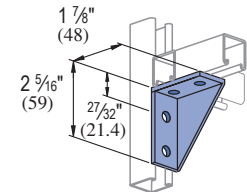

Wt/100 pcs: 19 Lbs (8.6 kg)

Standard Dimensions for 13/16" (21mm) width series channel fittings (Unless Otherwise Shown on Drawing)

Hole Diameter: 9/32" (7mm); Hole Spacing - From End: 13/32" (10mm); Hole Spacing - On Center: 1 1/16" (27mm); Width: 13/16" (21mm); Thickness: 1/8" (3mm)



P6332

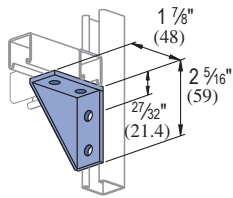

Wt/100 pcs: 19 Lbs (8.6 kg)

P6546, P7097, P7098, P7100, P7101

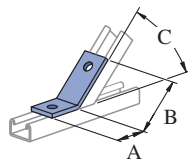

Wt/100 pcs: 8 Lbs (3.6 kg)

| Part Number | A In (mm) | "B" In (mm) | "C" Deg (rad) |
|-------------|--------------------------------------|---------------------------------------|---|
| P7097 | 1 ⁵ / ₁₆ 24 | 1 ¹³ / ₁₆ 46 | 60° 1.1 |
| P7098 | 1 ¹ / ₂ 26 | 1 ⁷ / ₈ 48 | 52 ¹ / ₂ ° 9.1 |
| P6546 | 1 ³ / ₁₆ 30 | 1 ²³ / ₃₂ 44 | 45° 0.8 |
| P7100 | 1 ⁵ / ₁₆ 33 | 1 ¹⁹ / ₃₂ 41 | 37 ¹ / ₂ ° 6.5 |
| P7101 | 1 ¹ / ₂ 26 | 1 ⁷ / ₈ 48 | 30° 0.5 |

P6186, P7108, P7109, P7110

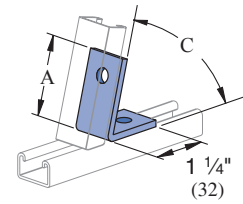

| Part No. | "A" In (mm) | "C" Deg (rad) |
|----------|---------------------------------------|---|
| P7108 | 1 ²⁷ / ₃₂ 47 | 60° 1.1 |
| P7109 | 1 ¹³ / ₁₆ 46 | 52 ¹ / ₂ ° 9.1 |
| P6186 | 1 ¹³ / ₁₆ 46 | 45° 0.8 |
| P7110 | 1 ¹³ / ₁₆ 46 | 37 ¹ / ₂ ° 6.5 |

P6045

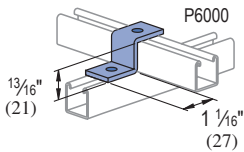

Wt/100 pcs: 7 Lbs (3.2 kg)

P7045

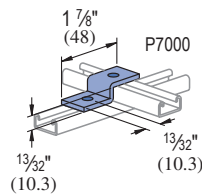

Wt/100 pcs: 6 Lbs (2.7 kg)

P6347

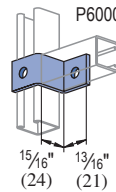

Wt/100 pcs: 7 Lbs (3.2 kg)

P7347

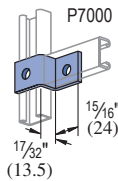

Wt/100 pcs: 6 Lbs (2.7 kg)

P6453

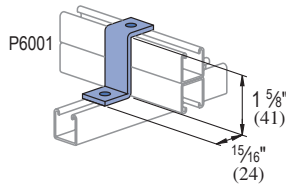

Wt/100 pcs: 9 Lbs (4.1 kg)

P6454

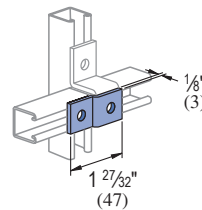

Wt/100 pcs: 5 Lbs (2.3 kg)

P6758

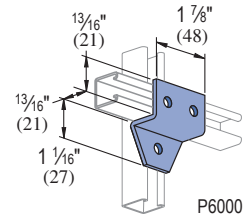

Wt/100 pcs: 13 Lbs (5.9 kg)

P7758

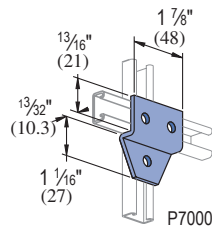

Wt/100 pcs: 12 Lbs (5.4 kg)

P6047, P7047

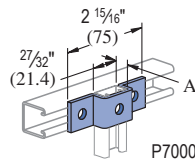

| Part No. | A In (mm) | Wt/100 pcs Lbs (kg) | Use with Channel |
|----------|--|------------------------|------------------|
| P6047 | 1 ³ / ₁₆ 20.6 | 12 5.4 | P6000 |
| P7047 | 1 ³ / ₃₂ 10.3 | 10 4.5 | P7000 |

P6737

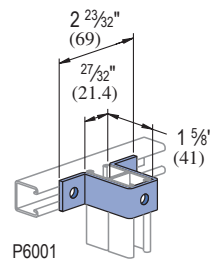

Wt/100 pcs: 16 Lbs (7.3 kg)

P6048

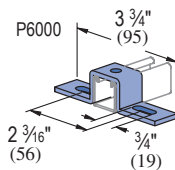

Wt/100 pcs: 14 Lbs (6.4 kg)

Standard Dimensions for 1³/₁₆" (21mm) width series channel fittings (Unless Otherwise Shown on Drawing)

Hole Diameter: 9/32" (7mm); Hole Spacing - From End: 1³/₃₂" (10mm); Hole Spacing - On Center: 1¹/₁₆" (27mm); Width: 1³/₁₆" (21mm); Thickness: 1/8" (3mm)

1⁵/₈" Channel
 Telestrut System
 Hardware
 General Fittings
 Pipe/Conduit Supports
 Electrical Fittings
 Concrete Inserts
 1¹/₄" Framing System
 1³/₁₆" Framing System
 Fiberglass System
 Special Metals
 PrimeAngle System
 Product Index

P7048

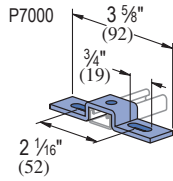

Wt/100 pcs: 10 Lbs (4.5 kg)

P6376

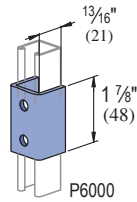

Wt/100 pcs: 17 Lbs (7.7 kg)

P7376

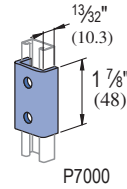

Wt/100 pcs: 11 Lbs (5.0 kg)

P6376A

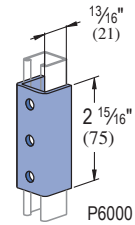

Wt/100 pcs: 26 Lbs (11.8 kg)

P7376A

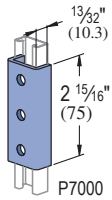

Wt/100 pcs: 16 Lbs (7.3 kg)

P6377

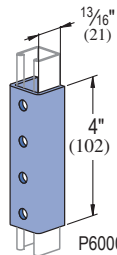

Wt/100 pcs: 36 Lbs (16.3 kg)

P7377

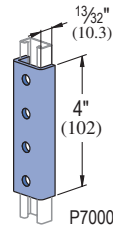

Wt/100 pcs: 24 Lbs (10.9 kg)

P6044

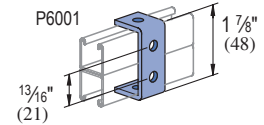

Wt/100 pcs: 9 Lbs (4.1 kg)

P6455

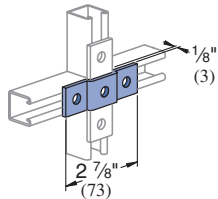

Wt/100 pcs: 8 Lbs (3.6 kg)

P6973

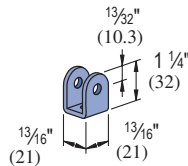

Wt/100 pcs: 8 Lbs (3.6 kg)

P6349

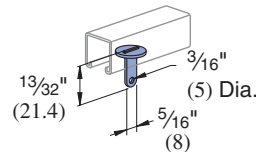

Wt/100 pcs: 1 Lbs (0.5 kg)

ACETAL SLIDE

P6353

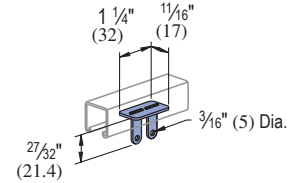

Wt/100 pcs: 1 Lbs (0.5 kg)

ACETAL SLIDE

P6127 - P6129

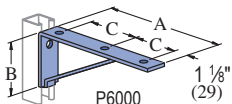

BRACKET

| Part No. | Uniform Design Load Lbs (kN) | "A" In (mm) | "B" In (mm) | "C" In (mm) | Wt/100 pcs Lbs (kg) |
|----------|------------------------------|---------------|-------------|--------------|---------------------|
| P6127 | 150 0.67 | 6 1/2 165 | 2 1/2 64 | 2 1/2 64 | 30 13.6 |
| P6128 | 150 0.67 | 8 1/2 216 | 3 1/4 83 | 3 1/2 89 | 40 18.1 |
| P6129 | 130.0 0.58 | 10 1/2 267 | 4 102 | 4 1/2 114 | 50 22.7 |

Standard Dimensions for 1 3/16" (21mm) width series channel fittings (Unless Otherwise Shown on Drawing)

Hole Diameter: 3/32" (2.4mm) Hole Spacing - From End: 1 3/32" (10mm); Hole Spacing - On Center: 1 1/16" (27mm); Width: 1 3/16" (21mm); Thickness: 1/8" (3mm)



P6386

Use in pairs.

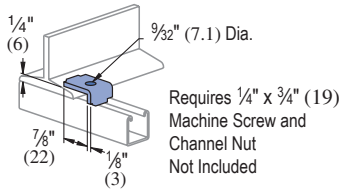

Wt/100 pcs: 4 Lbs (1.8 kg)

P6379 S

Use in pairs.

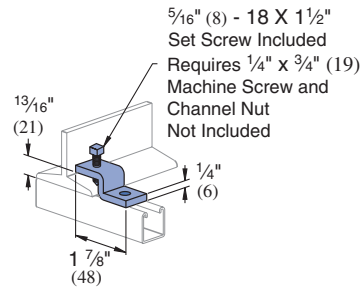

Wt/100 pcs: 13 Lbs (5.9 kg)

P7008 THRU P7020

TUBING CLIPS

P6805 THRU P6810

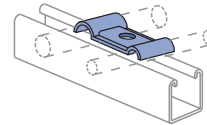
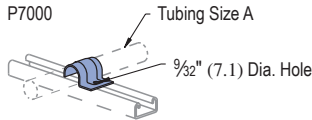

Material: 16 Gauge (1.5)

| Part Number | O.D. Tube Size "A" In (mm) | Wt/100 pcs Lbs (kg) |
|-------------|----------------------------|---------------------|
| P7008 | 1/4 6 | 1 0.45 |
| P7009 | 5/16 8 | 1 0.45 |
| P7010 | 3/8 10 | 2 0.91 |
| P7012 | 1/2 13 | 2 0.91 |
| P7014 | 5/8 16 | 3 1.4 |
| P7016 | 3/4 19 | 4 1.8 |
| P7018 | 7/8 23 | 5 2.3 |
| P7020 | 1 25 | 5 2.3 |

| Part Number | O.D. Tube Size "A" In (mm) | O.D. Tube Size "B" In (mm) | "C" In (mm) | Wt/100 pcs Lbs (kg) |
|-------------|----------------------------|----------------------------|-------------|---------------------|
| P6805 | 1/4 6 | 1/4 6 | 3/4 19 | 1 0.5 |
| P6806 | 3/8 10 | 3/8 10 | 1 25 | 2 0.9 |
| P6807 | 1/2 13 | 1/2 13 | 1 1/4 32 | 3 1.4 |
| P6808 | 1/4 6 | 3/8 10 | 7/8 22 | 2 0.9 |
| P6809 | 1/4 6 | 1/2 13 | 1 25 | 2 0.9 |
| P6810 | 3/8 10 | 1/2 13 | 1 1/8 29 | 3 1.4 |

15/16" Channel
 Telestrut System
 Nuts & Hardware
 General Fittings
 Pipe/Conduit Supports
 Electrical Fittings
 Concrete Inserts
 1 1/4" Framing System
 13/16" Framing System
 Fiberglass System
 Special Metals
 PrimeAngle System
 Product Index

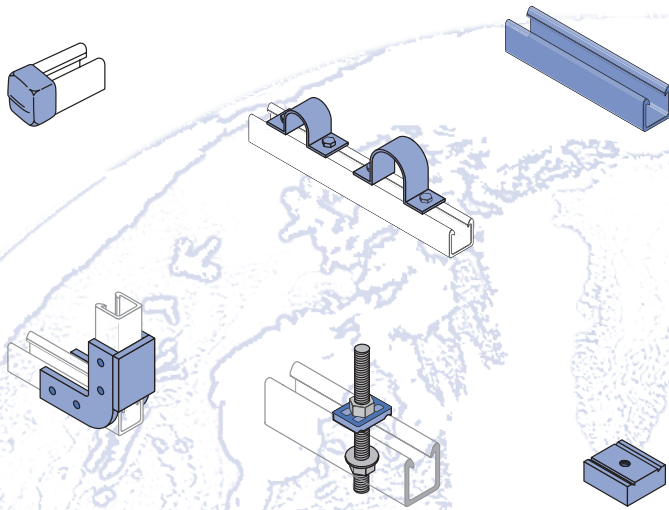

Heavy Duty Channel (Flange Profile) 169

Light Duty Channel (Flange Profile) 170

Heavy Duty Channel (SST Profile)..... 171

Nuts & Hardware 172-174

Fittings..... 175-176

Pipe Clamps 177

Clevis Hangers..... 178

Beam Clamps..... 179

Power Rack Stanchions 179

Chemical Compatibility 180-181

Specifications 182

POLYESTER AND VINYL ESTER MATERIALS

Polyester and vinyl ester channels are manufactured from the pultrusion process and are color coded gray and beige respectively. Components are made by reinforcing a polymer resin (polyester or vinyl ester) with multiple strands of glass filament, alternating layers of glass mat and U.V. resistant surfacing veils. The glass is drawn through the liquid resin, which coats and saturates the fibers. The combination of resin, glass and veil is then continuously guided and pulled (pultruded) through a heated die that determines the shape of the component.

In the die, the resin is cured to form a reinforced part which can be cut to length. The hardened fiberglass pultrusion is reinforced with an internal arrangement of permanently bonded continuous glass fibers to increase its strength.

INSTALLATION

Fabrication requires just three simple operations: cutting, drilling and sealing as described below.

Cutting – Hand held saws, such as hack saws (24 to 32 teeth per inch) are suitable when a few cuts are required. For frequent cutting, a circular power saw with a carbide-tipped masonry blade yields the best results. When using a power saw, dust filter masks, gloves and long sleeve clothing should be worn.

Drilling – Any standard twist bit, even when used with battery-powered drills will work well. Carbide-tipped drill bits are recommended.

Sealing – To protect against future migration of corrosive elements into the cut sections, all cuts and holes should be properly sealed with clear urethane sealer.

OPERATING ENVIRONMENT

Temperature Ranges – Fiberglass parts are supplied in five different materials covering distinct temperature ranges. The temperature ranges indicated are meant to be used only as a general guideline. Continual exposure to elevated temperatures reduces the strength properties of plastics and glass-reinforced fiberglass. Actual resin test data confirms that a 50% reduction in strength occurs at the extreme high temperature levels.

Chemical Resistance – See the chart on page 269 for corrosion resistance. The results are based upon immersion for a 24 hour period. This is typically the “worst case” exposure to corrosion. Less severe contact such as spills, splashes and vapor condensate will exceed the performance results listed in the table.

Loading – Channel loading is defined with description of each type of channel. Additional loading and design limitations for fittings and accessories are described in the appropriate section for that part.

| Material Temperature Ratings | | |
|------------------------------|---------------|--------------|
| Material Code | Low Temp. | High Temp. |
| E - (Rigid PVC) | -25°F (-31°C) | 130°F (54°C) |
| P - (Poly/Glass) | -35°F (-37°C) | 200°F (93°C) |
| V - (Vinyl/Glass) | -35°F (-37°C) | 200°F (93°C) |
| PU - (Poly) | -40°F (-40°C) | 140°F (60°C) |
| N - (Nylon) | -20°F (-29°C) | 150°F (66°C) |



Channel - Patented Flange Profile

Unistrut fiberglass channels, except the SST series, incorporate a patented flange design which provides reliable fastening and interlocking of components and accessories. It is important to note that standard metal framing components such as pipe clamps and strut nuts will not work with the flange design.

Heavy Duty Patented Flange Profile
1 5/8" x 1 5/8"

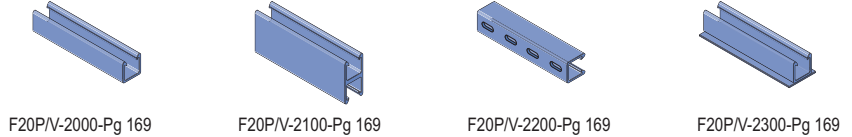

Light Duty Patented Flange Profile
1 1/2" x 1 1/8"

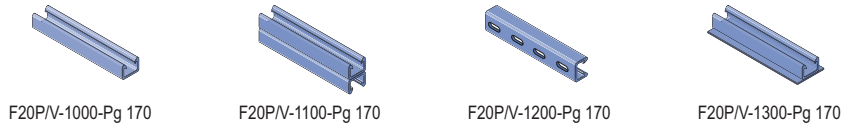

Channel - SST Profile

The Unistrut SST profile is similar to the profile of standard metal channel. The Unistrut SST profile will accommodate standard 1 5/8" metal channel fittings and components. This profile is available in polyester or vinyl ester resin. The Unistrut SST profile is not compatible with the fiberglass pipe clamps and channel nuts shown in this section. Typically, stainless steel clamps and strut nuts (listed elsewhere in this catalog) are used with this profile.

Heavy Duty SST Profile
1 5/8" x 1 5/8"

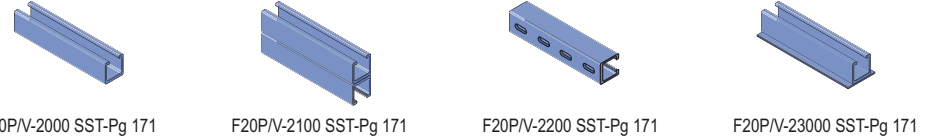

Hardware & Accessories

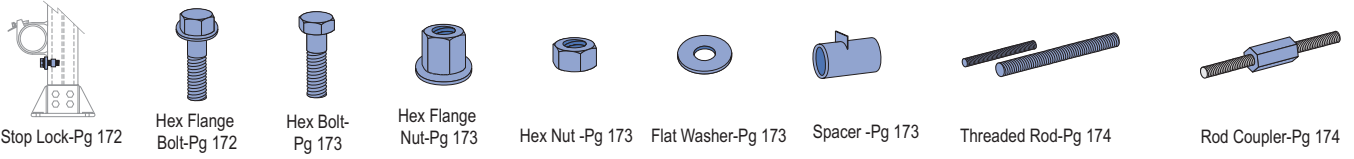

Fittings

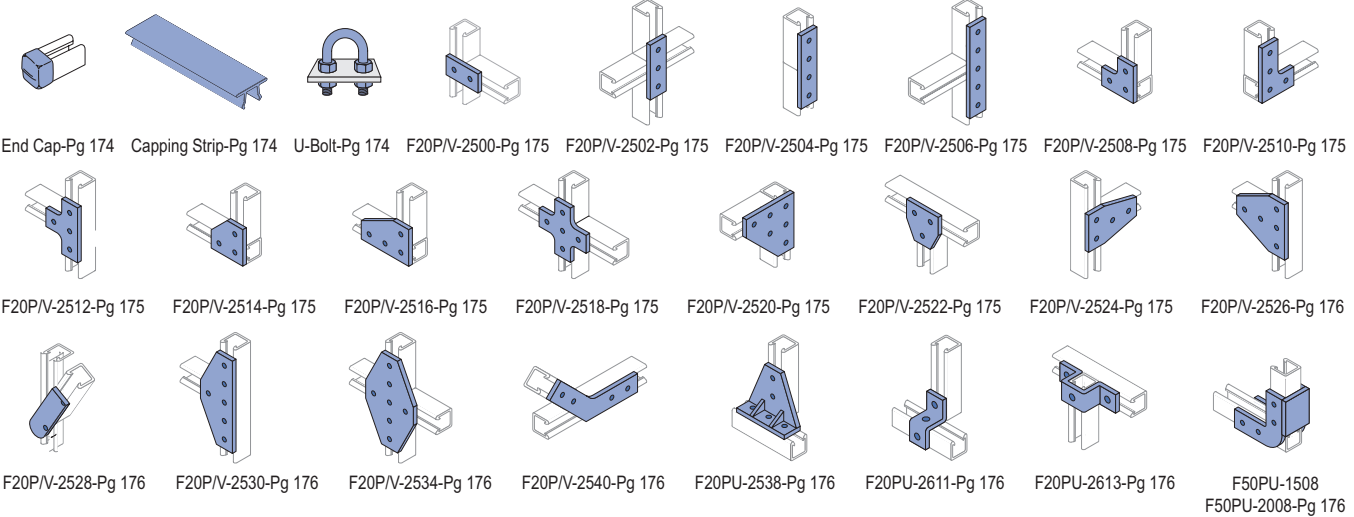

Pipe Clamps, Beam Clamps and Stanchions

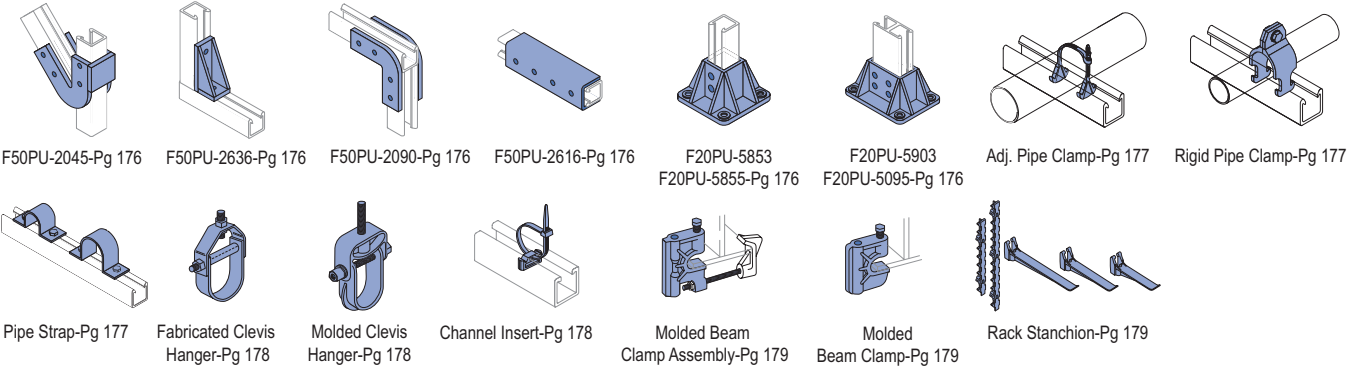

1 5/8" Channel
 Telestrut System
 Nuts & Hardware
 General Fittings
 Pipe/Conduit Supports
 Electrical Fittings
 Concrete Inserts
 1 1/4" Framing System
 1 3/16" Framing System
 Fiberglass System
 Special Metals
 PrimeAngle System
 Product Index

F20P-2000, F20V-2000

HEAVY DUTY SINGLE CHANNEL - PATENTED FLANGE PROFILE

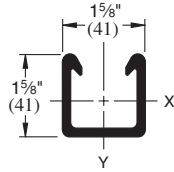
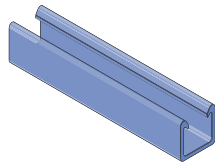

Wt/100 Ft: 82 Lbs(122 kg/100 m)

F20P-2100, F20V-2100

HEAVY DUTY BACK-TO-BACK CHANNEL - PATENTED FLANGE PROFILE

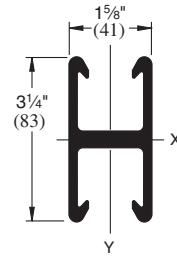
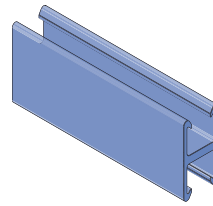

Wt/100 Ft: 164 Lbs (244 kg/100 m)

SECTION PROPERTIES

| Part Number | Weight lbs./ft. (kg/m) | Area in ² (mm ²) | ----- X - X Axis ----- | | | | ----- Y - Y Axis ----- | | |
|----------------------|------------------------|---|--------------------------------------|-----------|------------|------------|--------------------------------------|-----------|-----------|
| | | | I in ⁴ (mm ⁴) | R ln (mm) | C1 ln (mm) | C2 ln (mm) | I in ⁴ (mm ⁴) | R ln (mm) | C ln (mm) |
| F20P-2000, F20V-2000 | 0.82 | 1.06 | 0.31 | 0.54 | 0.7 | 0.93 | 0.42 | 0.63 | 0.82 |
| F20P-2100, F20V-2100 | 1.2 | 6.8 | 12.9 | 13.7 | 17.8 | 23.622 | 17.5 | 16.0 | 20.8 |
| F20P-2000, F20V-2000 | 1.64 | 2.12 | 1.77 | 0.91 | 1.63 | 1.63 | 0.85 | 0.63 | 0.82 |
| F20P-2100, F20V-2100 | 2.4 | 13.7 | 73.7 | 23.1 | 41.4 | 41.402 | 35.4 | 16.0 | 20.8 |

FLANGE LOADING

| Part Number | Pull-Out Strength* Lbs (kN) |
|----------------|-----------------------------|
| F20V-2000/2100 | 449 2.0 |
| F20P-2000/2100 | 360 1.6 |

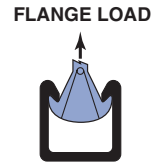

*Values shown represent a 3:1 safety factor

F20P-2200, F20V-2200

SLOTTED CHANNEL

Slots are 1" (25) x 7/16" (11)
2" (51) on Center

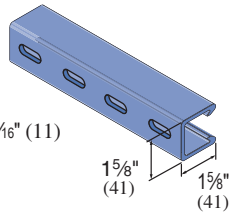

Wt/100 Ft: 82 Lbs (122 kg/100 m)

F20P-2300, F20V-2300

W/CONCRETE INSERT

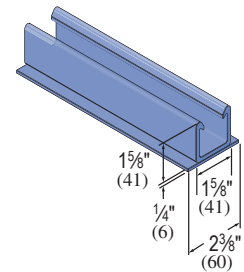
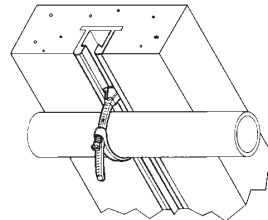

Wt/100 Ft: 88 Lbs (131 kg/100 m)

F20P-2000, F20V-2000

CHANNEL BEAM/COLUMN LOADING

| Span ln (mm) | Max. Uniform Beam Load (Safety Factor - 3:1) | | Uniform Load at Deflection of 1/360 Span | | Maximum Column Load Lbs (kN) |
|--------------|--|--------------------|--|--------------------|------------------------------|
| | Load Lbs (kN) | Deflection ln (mm) | Load Lbs (kN) | Deflection ln (mm) | |
| 12 | 3,561 | 0.102 | 1,159 | 0.033 | 5,160 |
| 305 | 15.8 | 2.6 | 5.2 | 0.8 | 23.0 |
| 18 | 2,374 | 0.23 | 515 | 0.05 | 4,704 |
| 457 | 10.6 | 5.8 | 2.3 | 1.3 | 20.9 |
| 24 | 1,781 | 0.41 | 290 | 0.067 | 4,168 |
| 610 | 7.9 | 10.4 | 1.3 | 1.7 | 18.5 |
| 30 | 1,424 | 0.64 | 185 | 0.083 | 3,553 |
| 762 | 6.3 | 16.3 | 0.8 | 2.1 | 15.8 |
| 36 | 1,187 | 0.922 | 129 | 0.1 | 2,859 |
| 914 | 5.3 | 23.4 | 0.6 | 2.5 | 12.7 |
| 48 | 890 | 1.638 | 72 | 0.133 | 1,636 |
| 1,219 | 4.0 | 41.6 | 0.3 | 3.4 | 7.3 |
| 60 | 712 | 2.56 | 46 | 0.167 | 1,047 |
| 1,524 | 3.2 | 65 | 0.2 | 4.2 | 4.7 |
| 72 | 594 | 3.686 | 32 | 0.2 | 727 |
| 1,829 | 2.6 | 93.6 | 0.1 | 5.1 | 3.2 |

F20P-2100, F20V-2100

CHANNEL BEAM/COLUMN LOADING

| Span ln (mm) | Max. Uniform Beam Load (Safety Factor - 3:1) | | Uniform Load at Deflection of 1/360 Span | | Maximum Column Load Lbs (kN) |
|--------------|--|--------------------|--|--------------------|------------------------------|
| | Load Lbs (kN) | Deflection ln (mm) | Load Lbs (kN) | Deflection ln (mm) | |
| 12 | 5,559 | 0.028 | 5,559 | 0.033 | 9,454 |
| 305 | 24.7 | 0.7 | 24.7 | 0.8 | 42.1 |
| 18 | 3,706 | 0.064 | 2,914 | 0.05 | 8,866 |
| 457 | 16.5 | 1.6 | 13.0 | 1.3 | 39.4 |
| 24 | 2,780 | 0.113 | 1,639 | 0.067 | 8,181 |
| 610 | 12.4 | 2.9 | 7.3 | 1.7 | 36.4 |
| 30 | 2,224 | 0.177 | 1,049 | 0.083 | 7,405 |
| 762 | 9.9 | 4.5 | 4.7 | 2.1 | 32.9 |
| 36 | 1,853 | 0.254 | 730 | 0.1 | 6,451 |
| 914 | 8.2 | 6.5 | 3.2 | 2.5 | 28.7 |
| 48 | 1,390 | 0.452 | 410 | 0.133 | 4,534 |
| 1,219 | 6.2 | 11.5 | 1.8 | 3.4 | 20.2 |
| 60 | 1,112 | 0.707 | 262 | 0.167 | 2,902 |
| 1,524 | 4.9 | 18.0 | 1.2 | 4.2 | 12.9 |
| 72 | 927 | 1.018 | 182 | 0.2 | 2,015 |
| 1,829 | 4.1 | 25.9 | 0.8 | 5.1 | 9.0 |



F20P-1000, F20V-1000

LIGHT DUTY SINGLE CHANNEL - PATENTED FLANGE PROFILE

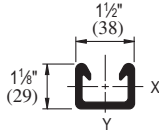
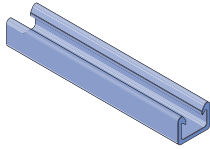

Wt/100 Ft: 47 Lbs (70 kg/100 m)

F20P-1100, F20V-1100

LIGHT DUTY BACK-TO-BACK CHANNEL - PATENTED FLANGE PROFILE

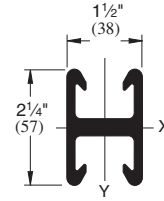
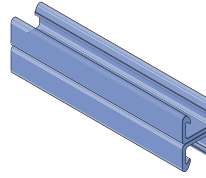

Wt/100 Ft: 94 Lbs (140 kg/100 m)

SECTION PROPERTIES

| Part Number | Weight lbs./ft. (kg/m) | Area in ² (mm ²) | X - X Axis | | | Y - Y Axis | | | |
|----------------------|------------------------|---|--------------------------------------|-----------|------------|------------|--------------------------------------|-----------|-----------|
| | | | I in ⁴ (mm ⁴) | R In (mm) | C1 In (mm) | C2 In (mm) | I in ⁴ (mm ⁴) | R In (mm) | C In (mm) |
| F20P-1000, F20V-1000 | 0.47 | 0.61 | 0.1 | 0.4 | 0.51 | 0.62 | 0.22 | 0.6 | 0.75 |
| F20P-1100, F20V-1100 | 0.7 | 3.9 | 4.2 | 10 | 13 | 16 | 9.2 | 15 | 19 |
| F20P-1000, F20V-1000 | 0.94 | 1.22 | 0.42 | 0.59 | 1.13 | 1.13 | 0.44 | 0.6 | 0.75 |
| F20P-1100, F20V-1100 | 1.4 | 7.9 | 17.5 | 15 | 29 | 28 | 18.3 | 15 | 19.1 |

FLANGE LOADING

| Part Number | Pull-Out Strength* Lbs (kN) |
|----------------|-----------------------------|
| F20V-1000/1100 | 213 1.0 |
| F20P-1000/1100 | 213 1.0 |

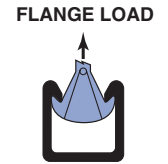

*Values shown represent a 3:1 safety factor

F20P-1200, F20V-1200

SLOTTED CHANNEL

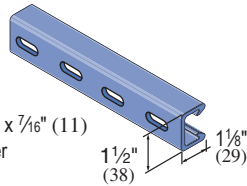

Slots are 1" (25) x 7/16" (11)
2" (51) on Center

Wt/100 Ft: 47 Lbs (70 kg/100 m)

F20P-1300, F20V-1300

W/CONCRETE INSERT

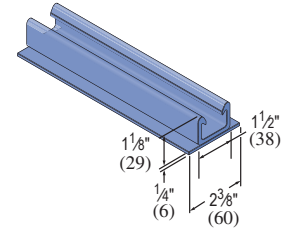
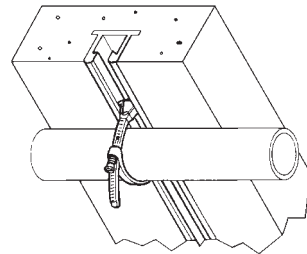

Wt/100 Ft: 53 Lbs (79 kg/100 m)

F20P-1000, F20V-1000

CHANNEL BEAM/COLUMN LOADING

| Span In (mm) | Max. Uniform Beam Load (Safety Factor - 3:1) | | Uniform Load at Deflection of 1/360 Span | | Maximum Column Load Lbs (kN) |
|--------------|--|--------------------|--|--------------------|------------------------------|
| | Load Lbs (kN) | Deflection In (mm) | Load Lbs (kN) | Deflection In (mm) | |
| 12 | 1,629 | 0.151 | 359 | 0.033 | 2,759 |
| 305 | 7.2 | 3.8 | 1.6 | 0.8 | 12.3 |
| 18 | 1,086 | 0.340 | 160 | 0.050 | 2,351 |
| 457 | 4.8 | 8.6 | 0.7 | 1.3 | 10.5 |
| 24 | 815 | 0.605 | 90 | 0.067 | 1,862 |
| 610 | 3.6 | 15.4 | 0.4 | 1.7 | 8.3 |
| 30 | 652 | 0.945 | 57 | 0.083 | 1,298 |
| 762 | 2.9 | 24.0 | 0.3 | 2.1 | 5.8 |
| 36 | 543 | 1.360 | 40 | 0.100 | 901 |
| 914 | 2.4 | 34.5 | 0.2 | 2.5 | 4.0 |
| 48 | 407 | 2.418 | 22 | 0.133 | 507 |
| 1,219 | 1.8 | 61.4 | 0.1 | 3.4 | 2.3 |
| 60 | 326 | 3.779 | 14 | 0.167 | 324 |
| 1,524 | 1.5 | 96.0 | 0.1 | 4.2 | 1.4 |
| 72 | 272 | 5.441 | 10 | 0.200 | 225 |
| 1,829 | 1.2 | 138.2 | 0.0 | 5.1 | 1.0 |

F20P-1100, F20V-1100

CHANNEL BEAM/COLUMN LOADING

| Span In (mm) | Max. Uniform Beam Load (Safety Factor - 3:1) | | Uniform Load at Deflection of 1/360 Span | | Maximum Column Load Lbs (kN) |
|--------------|--|--------------------|--|--------------------|------------------------------|
| | Load Lbs (kN) | Deflection In (mm) | Load Lbs (kN) | Deflection In (mm) | |
| 12 | 3,804 | 0.082 | 1,556 | 0.033 | 5,961 |
| 305 | 16.9 | 2.1 | 6.9 | 0.8 | 26.5 |
| 18 | 2,536 | 0.183 | 691 | 0.05 | 5,509 |
| 457 | 11.3 | 4.6 | 3.1 | 1.3 | 24.5 |
| 24 | 1,902 | 0.326 | 389 | 0.067 | 4,979 |
| 610 | 8.5 | 8.3 | 1.7 | 1.7 | 22.1 |
| 30 | 1,522 | 0.509 | 249 | 0.083 | 4,375 |
| 762 | 6.8 | 12.9 | 1.1 | 2.1 | 19.5 |
| 36 | 1,268 | 0.734 | 173 | 0.1 | 3,698 |
| 914 | 5.6 | 18.6 | 0.8 | 2.5 | 16.4 |
| 48 | 951 | 1.304 | 97 | 0.133 | 2,254 |
| 1,219 | 4.2 | 33.1 | 0.4 | 3.4 | 10.0 |
| 60 | 761 | 2.038 | 62 | 0.167 | 1,442 |
| 1,524 | 3.4 | 51.8 | 0.3 | 4.2 | 6.4 |
| 72 | 634 | 2.935 | 43 | 0.2 | 1,001 |
| 1,829 | 2.8 | 74.5 | 0.2 | 5.1 | 4.5 |

1 1/2" Channel
 Telesrnut System
 Nuts & Hardware
 General Fittings
 Pipe/Conduit Supports
 Electrical Fittings
 Concrete Inserts
 1 1/4" Framing System
 1 3/16" Framing System
 Fiberglass System
 Special Metals
 PrimeAngle System
 Product Index

F20P-2000 SST, F20V-2000 SST
HEAVY DUTY SINGLE CHANNEL - SST PROFILE

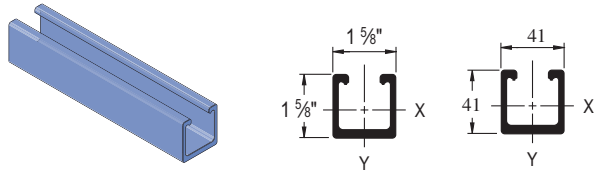

Wt/100 Ft: 82 Lbs (122 kg/100 m)

F20P-2100 SST, F20V-2100 SST
HEAVY DUTY BACK-TO-BACK CHANNEL - SST PROFILE

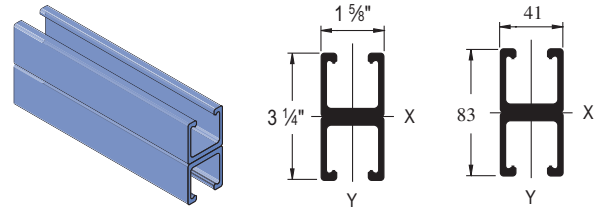

Wt/100 Ft: 164 Lbs (244 kg/100 m)

F20P-2200 SST, F20V-2200 SST **SLOTTED CHANNEL**

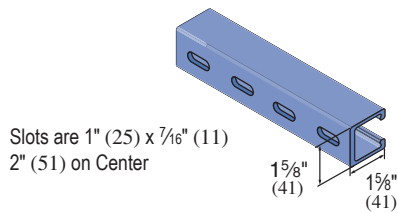

Wt/100 Ft: 82 Lbs (122 kg/100 m)

F20P-2300 SST, F20V-2300 SST **w/CONCRETE INSERT**

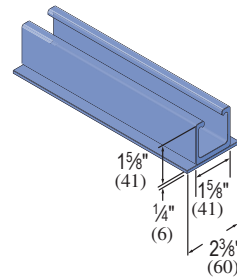

Wt/100 Ft: 88 Lbs (131 kg/100 m)

NOTE: Unistrut SST Channel is not compatible with the Unistrut fiberglass pipe clamps and channel nuts shown in this catalog. Metal clamps and channel nuts are compatible with this profile and are shown elsewhere in this catalog.

F20P-2000 SST, F20V-2000 SST
CHANNEL BEAM/COLUMN LOADING

| Span In (mm) | Maximum Uniform Beam Load (Safety Factor - 3:1) | | Deflection @ Max. Allowable Beam Load | | Deflection @ Max. Deflection = 0.25 In (Lbs) | | Uniform Load @ Max. Deflection = 0.50 In (Lbs) | | Max. Column Load Lbs (kN) |
|--------------------|--|----------------------|--|---------------------|--|----------------------|---|----------------------|------------------------------------|
| | Poly Lbs (kN) | Vinyl Lbs (kN) | Poly In (mm) | Vinyl In (mm) | Poly Lbs (kN) | Vinyl Lbs (kN) | Poly Lbs (kN) | Vinyl Lbs (kN) | |
| 12 | 1,720 | 2,150 | 0.07 | 0.07 | — | — | — | — | 3,650 |
| 305 | 7.6 | 9.6 | 1.8 | 1.8 | — | — | — | — | 16.2 |
| 18 | 1,150 | 1,440 | 0.15 | 0.17 | — | — | — | — | 3,370 |
| 457 | 5.1 | 6.4 | 3.8 | 4.3 | — | — | — | — | 15.0 |
| 24 | 860 | 1,080 | 0.27 | 0.3 | 810 | 910 | — | — | 2,960 |
| 610 | 3.8 | 4.8 | 6.9 | 7.6 | 3.6 | 4.0 | — | — | 13.2 |
| 30 | 690 | 870 | 0.42 | 0.48 | 410 | 460 | — | — | 2,450 |
| 762 | 3.1 | 3.9 | 10.7 | 12.2 | 1.8 | 2.0 | — | — | 10.9 |
| 36 | 580 | 730 | 0.61 | 0.69 | 240 | 270 | 480 | 540 | 1,800 |
| 914 | 2.6 | 3.2 | 15.5 | 17.5 | 1.1 | 1.2 | 2.1 | 2.4 | 8.0 |
| 48 | 430 | 540 | 1.07 | 1.2 | 100 | 115 | 200 | 230 | 1,010 |
| 1,219 | 1.9 | 2.4 | 27.2 | 30.5 | 0.4 | 0.5 | 0.9 | 1.0 | 4.5 |
| 60 | 350 | 440 | 1.7 | 1.91 | 60 | 70 | 120 | 135 | 260 |
| 1,524 | 1.6 | 2.0 | 43.2 | 48.5 | 0.3 | 0.3 | 0.5 | 0.6 | 1.2 |
| 72 | 290 | 370 | 2.44 | 2.78 | 30 | 34 | 60 | 70 | NR |
| 1,829 | 1.3 | 1.6 | 62.0 | 70.6 | 0.1 | 0.2 | 0.3 | 0.3 | NR |

F20P-2100 SST, F20V-2100 SST
CHANNEL BEAM/COLUMN LOADING

| Span In (mm) | Maximum Uniform Beam Load (Safety Factor - 3:1) | | Deflection @ Max. Allowable Beam Load | | Deflection @ Max. Deflection = 0.25 In (Lbs) | | Uniform Load @ Max. Deflection = 0.50 In (Lbs) | | Max. Column Load Lbs (kN) |
|--------------------|--|----------------------|--|---------------------|--|----------------------|---|----------------------|------------------------------------|
| | Poly Lbs (kN) | Vinyl Lbs (kN) | Poly In (mm) | Vinyl In (mm) | Poly Lbs (kN) | Vinyl Lbs (kN) | Poly Lbs (kN) | Vinyl Lbs (kN) | |
| 12 | 5,080 | 6,350 | 0.04 | 0.04 | — | — | — | — | 7,300 |
| 305 | 22.6 | 28.2 | 1.0 | 1.0 | — | — | — | — | 32.5 |
| 18 | 3,390 | 4,240 | 0.09 | 0.1 | — | — | — | — | 6,740 |
| 457 | 15.1 | 18.9 | 2.3 | 2.5 | — | — | — | — | 30.0 |
| 24 | 2,540 | 3,180 | 0.16 | 0.17 | — | — | — | — | 5,920 |
| 610 | 11.3 | 14.1 | 4.1 | 4.3 | — | — | — | — | 26.3 |
| 30 | 2,040 | 2,550 | 0.24 | 0.27 | — | 2,350 | — | — | 4,900 |
| 762 | 9.1 | 11.3 | 6.1 | 6.9 | — | 10.5 | — | — | 21.8 |
| 36 | 1,700 | 2,130 | 0.35 | 0.39 | 1,220 | 1,370 | — | — | 3,600 |
| 914 | 7.6 | 9.5 | 8.9 | 9.9 | 5.4 | 6.1 | — | — | 16.0 |
| 48 | 1,270 | 1,590 | 0.62 | 0.69 | 520 | 590 | 1,040 | 1,170 | 2,020 |
| 1,219 | 5.6 | 7.1 | 15.7 | 17.5 | 2.3 | 2.6 | 4.6 | 5.2 | 9.0 |
| 60 | 1,020 | 1,280 | 0.97 | 1.09 | 270 | 310 | 540 | 610 | 520 |
| 1,524 | 4.5 | 5.7 | 24.6 | 27.7 | 1.2 | 1.4 | 2.4 | 2.7 | 2.3 |
| 72 | 850 | 1,070 | 1.4 | 1.57 | 160 | 180 | 320 | 360 | NR |
| 1,829 | 3.8 | 4.8 | 35.6 | 39.9 | 0.7 | 0.8 | 1.4 | 1.6 | NR |



HEAVY DUTY CHANNEL NUTS

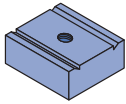

- Heavy duty channel nuts are designed to be used where high thread shear values or spring nuts are required. They can not be used with light duty 1000 series channel or SST profile channel.
- Material: glass-reinforced polyurethane.

| Part Number | Size | Thread Shear Lbs (kN)* | Torque Ft/Lbs (N•m) | Wt/100 pcs Lbs (kg) |
|-------------|---------|------------------------|---------------------|---------------------|
| F375PU-CNHD | 3/8"-16 | 1,400 | 8 | 5.7 |
| | | 6.23 | 11 | 2.6 |
| F500PU-CNHD | 1/2"-13 | 1,400 | 8 | 5.3 |
| | | 6.23 | 11 | 2.4 |
| F625PU-CNHD | 5/8"-11 | 1,400 | 10 | 5.1 |
| | | 6.23 | 14 | 2.3 |
| F750PU-CNHD | 3/4"-10 | 1,400 | 10 | 4.4 |
| | | 6.23 | 14 | 2.0 |
| F10PU-CNMHD | 10 mm | 1,400 | 8 | 5.8 |
| | | 6.23 | 11 | 2.6 |
| F12PU-CNMHD | 12 mm | 1,400 | 8 | 5.5 |
| | | 6.23 | 11 | 2.5 |
| F16PU-CNMHD | 16 mm | 1,400 | 10 | 5.3 |
| | | 6.23 | 14 | 2.4 |
| F20PU-CNMHD | 20 mm | 1,400 | 10 | 4.4 |
| | | 6.23 | 14 | 2.0 |

*Thread shear values shown represent a 3:1 safety factor.

SADDLE CLIPS

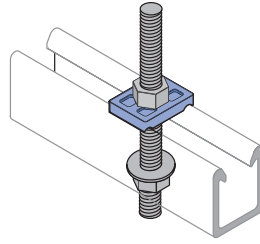

Saddle clips mate with the exterior of the channel flanges and are secured with threaded rods and nuts. Material: glass-reinforced polyurethane.

| Part Number | Size (In.) | Wt/100 pcs Lbs (kg) |
|-------------|------------|---------------------|
| F200-4226 | 3/8" | 3.5 |
| | | 1.6 |
| F200-4217 | 1/2" | 2.5 |
| | | 1.1 |
| F200-4341 | 5/8" | 3.0 |
| | | 1.4 |
| F200-4342 | 3/4" | 2.5 |
| | | 1.1 |

STOP-LOCK ASSEMBLIES

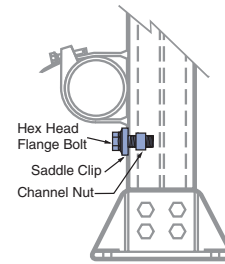

Stop-Lock Assemblies reduce the chance of pipe slippage when running supports vertically and are recommended for applications that are subject to vibration, have regular contact with fluids or are vertically mounted. The Stop-Locks fit both sizes of channel.

Material: glass-reinforced polyurethane.

| Part Number | Size (in.) | Force Resistance Lbs (kN)* | Torque Ft/Lbs (N•m) | Wt/100 pcs Lbs (kg) |
|-------------|------------|----------------------------|---------------------|---------------------|
| F200-4227 | 3/8" | 200 | 7 | 6.3 |
| | | 0.9 | 9 | 2.9 |
| F200-4219 | 1/2" | 220 | 12 | 6.4 |
| | | 1.0 | 16 | 2.9 |
| F200-4343 | 5/8*** | 250 | 15 | 11.0 |
| | | 1.1 | 20 | 5.0 |

* Force resistance values shown represents a 3:1 safety factor.

** Supplied with a heavy duty channel nut for use only with the heavy duty series 2000 channel.

STANDARD DUTY CHANNEL NUTS

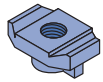

Standard Duty channel nuts are designed for light duty applications that do not require high thread shear values. They can be used with both light duty series 1000 and heavy duty series 2000 fiberglass channel. Not for use with SST profile channel. Material: glass-reinforced polyurethane.

| Part Number | Size | Thread Shear Lbs (kN)* | Torque Ft/Lbs (N•m) | Wt/100 pcs Lbs (kg) |
|-------------|-----------|------------------------|---------------------|---------------------|
| F250PU-CN | 1/4"-20 | 460 | 2 | 1.8 |
| | | 2.05 | 3 | 0.8 |
| F312PU-CN | 5/16"-18 | 460 | 2 | 1.7 |
| | | 2.05 | 3 | 0.8 |
| F375PU-CN | 3/8"-16 | 460 | 3 | 1.8 |
| | | 2.05 | 4 | 0.8 |
| F500PU-CN | 1/2"-13 | 460 | 3 | 1.4 |
| | | 2.05 | 4 | 0.6 |
| F10PU-CN | 10 mm | 460 | 3 | 1.7 |
| | | 2.05 | 4 | 0.8 |
| F12PU-CN | 12 mm | 460 | 3 | 1.4 |
| | | 2.05 | 4 | 0.6 |
| F10PU-CNS | #10 Screw | 460 | N/A | 1.9 |
| | | 2.05 | | 0.9 |

*Thread shear values shown represent a 3:1 safety factor.

HEX FLANGE BOLTS

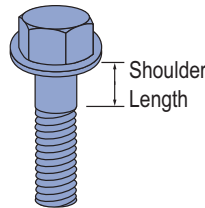

Fiberfast bolts are ideal for mechanical connections that require a high degree of corrosion resistance. The 3/8" diameter fasteners are recommended for all channel fitting mechanical connections. Material: glass-reinforced polyurethane.

| Part Number | Size (in.) | Thread Shear Lbs (kN)* | Shank Shear Lbs (kN)* | Shoulder Length In (mm) | Torque Ft/Lbs (N•m) | Wt/100 pcs Lbs (kg) |
|-------------|-------------|------------------------|-----------------------|-------------------------|---------------------|---------------------|
| F250PU-075 | 1/4 x 3/4 | 110 | 210 | Full Thread | 0.8 | .4 |
| | | 0.49 | 0.93 | | 1 | 0.2 |
| F250PU-100 | 1/4 x 1 | 110 | 210 | Full Thread | 0.8 | .5 |
| | | 0.49 | 0.93 | | 1 | .02 |
| F250PU-150 | 1/4 x 1 1/2 | 110 | 210 | 1/2 | 0.8 | .6 |
| | | 0.49 | 0.93 | 13 | 1 | 0.3 |
| F500PU-125 | 1/2 x 1 1/4 | 450 | 870 | Full Thread | 8 | 1.0 |
| | | 2.00 | 3.87 | | 11 | 0.5 |
| F500PU-150 | 1/2 x 1 1/2 | 450 | 870 | Full Thread | 8 | 1.1 |
| | | 2.00 | 3.87 | | 11 | .05 |
| F500PU-200 | 1/2 x 2 | 450 | 870 | 3/4 | 8 | 1.3 |
| | | 2.00 | 3.87 | 19 | 11 | 0.6 |
| F500PU-250 | 1/2 x 2 1/2 | 450 | 870 | Full Thread | 8 | 1.6 |
| | | 2.00 | 3.87 | | 11 | 0.7 |
| F500PU-300 | 1/2 x 3 | 450 | 870 | 1 | 8 | 1.8 |
| | | 2.00 | 3.87 | 25 | 11 | 0.8 |
| F500PU-350 | 1/2 x 3 1/2 | 450 | 870 | 2 3/16 | 8 | 2.0 |
| | | 2.00 | 3.87 | 56 | 11 | 0.9 |

*Thread shear values shown represent a 3:1 safety factor.

15/16" Channel
 Telesnut System
 Nuts & Hardware
 General Fittings
 Pipe/Conduit Supports
 Electrical Fittings
 Concrete Inserts
 1 1/4" Framing System
 1 3/16" Framing System
 Fiberglass System
 Special Metals
 PrimeAngle System
 Product Index

HEX BOLTS

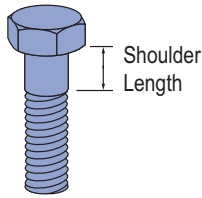

Fiberfast bolts are ideal for mechanical connections that require a high degree of corrosion resistance. The 3/8" diameter fasteners are recommended for all channel fitting mechanical connections. Material: glass-reinforced polyurethane.

| Part Number | Size (in.) | Thread Shear Lbs (kN)* | Shank Shear Lbs (kN)* | Shoulder Length In (mm) | Torque Ft/Lbs (N·m) | Wt/100 pcs Lbs (kg) |
|-------------|-------------|------------------------|-----------------------|-------------------------|---------------------|---------------------|
| F375PU-125 | 3/8 x 1 1/4 | 250 1.11 | 470 2.09 | Full Thread | 3 4 | 1.0 0.5 |
| F375PU-150 | 3/8 x 1 1/2 | 250 1.11 | 470 2.09 | 1/4 | 3 4 | 1.1 0.5 |
| F375PU-200 | 3/8 x 2 | 250 1.11 | 470 2.09 | 1/2 | 3 4 | 1.3 0.6 |
| F375PU-250 | 3/8 x 2 1/2 | 250 1.11 | 470 2.09 | 3/4 | 3 4 | 1.6 0.7 |
| F375PU-300 | 3/8 x 3 | 250 1.11 | 470 2.09 | 1 | 3 4 | 1.8 0.8 |
| F625PU-125 | 5/8 x 1 1/4 | 700 3.11 | 1,360 6.05 | 1/4 | 12 16 | 2.5 1.1 |
| F625PU-150 | 5/8 x 1 1/2 | 700 3.11 | 1,360 6.05 | 1/4 | 12 16 | 2.8 1.3 |
| F625PU-200 | 5/8 x 2 | 700 3.11 | 1,360 6.05 | 1/4 | 12 16 | 3.2 1.5 |
| F625PU-250 | 5/8 x 2 1/2 | 700 3.11 | 1,360 6.05 | 1/4 | 12 16 | 3.4 1.5 |
| F625PU-300 | 5/8 x 3 | 700 3.11 | 1,360 6.05 | 1/4 | 12 16 | 3.9 1.8 |
| F625PU-350 | 5/8 x 3 1/2 | 700 3.11 | 1,360 6.05 | 1 1/4 | 12 16 | 5.5 2.5 |

*Thread shear values shown represent a 3:1 safety factor.

FLAT WASHERS

Material: PVC

Note: PVC washers are recommended for connections that utilize hex nuts and bolts.

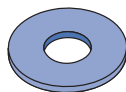

| Part Number | Size (in.) | Outside Diameter In (mm) | Wt/100 pcs Lbs (kg) |
|-------------|------------|--------------------------|---------------------|
| F250E-999 | 1/4 | 0.49 12 | 0.1 0.05 |
| F375E-999 | 3/8 | 1.00 25 | 0.1 0.05 |
| F500E-999 | 1/2 | 1.25 32 | 0.5 0.2 |
| F625E-999 | 5/8 | 1.50 38 | 0.5 0.2 |
| F750E-999 | 3/4 | 1.50 38 | 1.0 0.5 |
| F1000E-999 | 1 | 2.25 57 | 1.5 0.7 |

HEX FLANGE NUTS

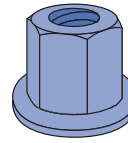

The hex flange nut is preferred for applications that require additional thread engagement (such as with all-thread rod) or maximum thread shear strength. Material: glass-reinforced polyurethane.

| Part Number | Size (in.) | Thread Shear Lbs (kN)* | Height In (mm) | Torque Ft/Lbs (N·m) | Wt/100 pcs Lbs (kg) |
|---------------|------------|------------------------|----------------|---------------------|---------------------|
| F375PU-FN-000 | 3/8-16 | 500 2.22 | 0.750 19.1 | 3 4 | 0.8 0.4 |
| F500PU-FN-000 | 1/2-13 | 1,200 5.34 | 0.855 21.7 | 8 11 | 1.6 0.7 |
| F625PU-FN-000 | 5/8-11 | 2,200 9.79 | 1.220 31.0 | 12 16 | 3.5 1.6 |
| F750PU-FN-000 | 3/4-10 | 2,900 12.90 | 1.590 40.4 | 15 20 | 5.5 2.5 |

*Thread shear values shown represent a 3:1 safety factor.

HEX NUTS

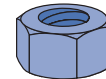

| Part Number | Size (in.) | Thread Shear Lbs (kN)* | Height In (mm) | Torque Ft/Lbs (N·m) | Wt/100 pcs Lbs (kg) |
|-------------|------------|------------------------|----------------|---------------------|---------------------|
| F250PU-000 | 1/4-20 | 150 0.67 | 0.218 5.5 | 0.8 1 | 0.1 0.05 |
| F375PU-000 | 3/8-16 | 460 2.05 | 0.328 8.3 | 3 4 | 0.3 0.1 |
| F500PU-000 | 1/2-13 | 800 3.56 | 0.437 11.1 | 8 11 | 0.5 0.2 |
| F625PU-000 | 5/8-11 | 1,000 4.45 | 0.546 13.9 | 12 16 | 1.5 0.7 |

*Thread shear values shown represent a 3:1 safety factor.

F50PU-500SP

CHANNEL SPACERS

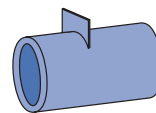

Channel spacers are designed to prevent wall compression under heavy loading conditions. Such loading occurs during the torquing of hardware for channel fittings.

The spacers are designed to be used only with 1 5/8" channels and will accommodate 3/8" and 1/2" bolts.

Material: molded from polyurethane

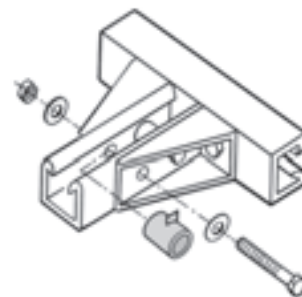

Wt/100 pcs: 2.0 Lbs (.91 kg)



THREADED ROD

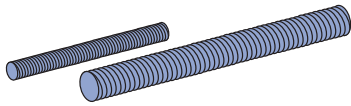

Material: pultruded vinyl ester resin and is gray in color.

* Thread shear values shown represent a 3:1 safety factor.
 ** Standard lengths are 4' and 8'. The part number shown is for 4' lengths. To order eight foot lengths, add suffix "-96" to part number (Example: F200-3827-96)

| Part Number | Size (in.) | Weight Lbs (kg) | Thread Shear Lbs (kN)* | Torque Ft/Lbs (N•m) | Wt/100 pcs 4' in Len. Lbs (kg) |
|-------------|------------|-----------------|------------------------|---------------------|--------------------------------|
| F200-3827 | 3/8-16 | 0.07 0.03 | 415 1.85 | 5 7 | 35 15.9 |
| F200-3828 | 1/2-13 | 0.12 0.05 | 570 2.54 | 10 14 | 57 25.9 |
| F200-3829 | 5/8-11 | 0.18 0.08 | 1,260 5.60 | 40 54 | 91 41.3 |
| F200-3830 | 3/4-10 | 0.28 0.13 | 1,700 7.56 | 50 68 | 133 60.3 |
| F200-3831 | 1-8 | 0.50 0.23 | 3,000 13.34 | 60 81 | 200 90.7 |

A-KONNECTOR ROD COUPLERS

A-Konnectors provide an excellent means for extending FRP all-thread rods beyond their standard lengths. A-Konnectors are manufactured from glass-reinforced polyurethane and are colored gray. A-Konnectors are packaged in bags containing 25 pieces.

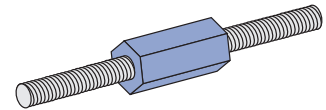

| Part Number | Size (in.) | Length In (mm) | Thread Shear Lbs (kN)* | Wt/100 pcs Lbs (kg) |
|-------------|------------|----------------|------------------------|---------------------|
| F200-3840 | 3/8-16 | 2 1/4 57 | 800 3.56 | 6.5 2.9 |
| F200-3841 | 1/2-13 | 2 1/4 57 | 870 3.87 | 6.0 2.7 |
| F200-3842 | 5/8-11 | 2 1/4 57 | 1,500 6.67 | 13.0 5.9 |
| F200-3843 | 3/4-10 | 2 1/4 57 | 1,500 6.67 | 11.0 5.0 |

* Thread shear values shown represent a 3:1 safety factor.

FAIC-EC – CHANNEL END CAP

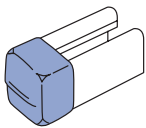

Material: red PVC and designed for 1 5/8" channel. End caps are desired when the ends of the channel need to be enclosed. The cap easily installs by pressing it onto the end of the channel opening.

Wt/100 pcs: 3.4 Lbs (1.5 kg)

F20E-5000 – CHANNEL CAPPING STRIP

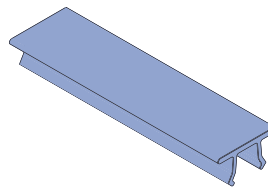

Material: PVC
 Installs simply by pressing it onto the channel opening. It is designed to be used when a cover is desired for the channel opening (such as concrete embedment channel).

Supplied in 10 foot lengths.



Wt/100 Ft: 5 Lbs (7.4 kg/100 m)

NONMETALLIC U-BOLTS

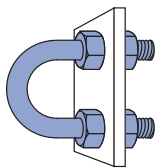
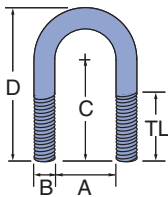

Note: Plate not included. Illustration purpose only

*Torque and load values shown represent a 3:1 safety factor.

| Part Number | Size In | "A" Dim. In (mm) | "B" Dim. In (mm) | "C" Dim. In (mm) | "D" Dim. In (mm) | "TL" Dim. In (mm) | Load Lbs (kN)* | Torque In/Lbs (N•m) | Wt/100 pcs Lbs (kg) |
|-------------|---------|------------------|------------------|------------------|------------------|-------------------|----------------|---------------------|---------------------|
| FUB-050 | 1/2 | 0.937 23.8 | 0.375 9.5 | 1.568 39.8 | 2.412 61.3 | 1.25 31.8 | 135 0.60 | 40 5 | 3 1.4 |
| FUB-075 | 3/4 | 1.125 28.6 | 0.375 9.5 | 1.662 42.2 | 2.600 66.0 | 1.25 31.8 | 135 0.60 | 40 5 | 3 1.4 |
| FUB-100 | 1 | 1.375 34.9 | 0.375 9.5 | 1.787 45.4 | 2.850 72.4 | 1.25 31.8 | 135 0.60 | 40 5 | 4 1.8 |
| FUB-125 | 1 1/4 | 1.687 42.8 | 0.375 9.5 | 1.943 49.4 | 3.162 80.3 | 1.25 31.8 | 135 0.60 | 40 5 | 4 1.8 |
| FUB-150 | 1 1/2 | 2.000 50.8 | 0.375 9.5 | 2.100 53.3 | 3.475 88.3 | 1.25 31.8 | 135 0.60 | 40 5 | 5 2.3 |
| FUB-200 | 2 | 2.437 61.9 | 0.500 12.7 | 2.468 62.7 | 4.187 106.3 | 1.50 38.1 | 135 0.60 | 80 9 | 10 4.5 |
| FUB-250 | 2 1/2 | 2.937 74.6 | 0.500 12.7 | 2.718 69.0 | 4.687 119.0 | 1.50 38.1 | 135 0.60 | 80 9 | 11 5.0 |
| FUB-300 | 3 | 3.562 90.5 | 0.500 12.7 | 3.031 77.0 | 5.312 134.9 | 1.50 38.1 | 135 0.60 | 80 9 | 14 6.4 |
| FUB-350 | 3 1/2 | 4.062 103.2 | 0.500 12.7 | 3.281 83.3 | 5.812 147.6 | 1.50 38.1 | 135 0.60 | 80 9 | 15 6.8 |
| FUB-400 | 4 | 4.562 115.9 | 0.500 12.7 | 3.531 89.7 | 6.312 160.3 | 1.50 38.1 | 135 0.60 | 80 9 | 16 7.3 |
| FUB-600 | 6 | 6.750 171.5 | 0.625 15.9 | 5.750 146.1 | 9.875 250.8 | 3.25 82.6 | 135 0.60 | 120 14 | 17 7.7 |

- Unistrut Nonmetallic U-Bolts provide a corrosion resistant alternative to traditional metallic U-Bolts. They have oversized diameters which allow them to hold steel conduit and plastic pipe. These bolts will outlast stainless steel in most corrosive applications.
- Each U-Bolt comes with two polyurethane hex nuts. Additional nuts and washers can be purchased separately.
- Material: glass-reinforced polyurethane

1 5/8" Channel
 Telesruct System
 Nuts & Hardware
 General Fittings
 Pipe/Conduit Supports
 Electrical Fittings
 Concrete Inserts
 1 1/4" Framing System
 1 3/8" Framing System
 Fiberglass System
 Special Metals
 PrimeAngle System
 Product Index

CHANNEL FITTINGS

Channel Fittings are required to fabricate structures and are easily attached to Channels with channel nuts and polyurethane fasteners. The fittings are offered in two types; fabricated (cut from flat stock) or molded.

Material (Fabricated Fittings):

Either polyester (P Series) or vinyl ester (V Series) material.

Material (Molded Fittings): All molded fittings with the exception of the post bases are molded in polyurethane.

Note: The drawings for all fittings are shown with the patented flange profile, however they can be used with either channel profile.

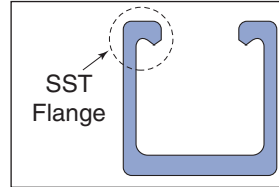
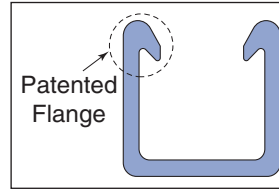

F20P-2500, F20V-2500

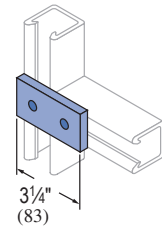

Wt/100 pcs: 12 Lbs (5.4 kg)

F20P-2502, F20V-2502

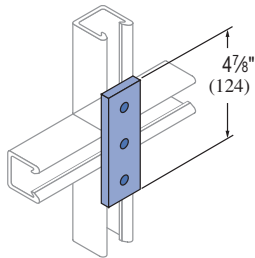

Wt/100 pcs: 17 Lbs (7.7 kg)

F20P-2504, F20V-2504

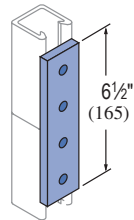

Wt/100 pcs: 24 Lbs (10.9 kg)

F20P-2506, F20V-2506

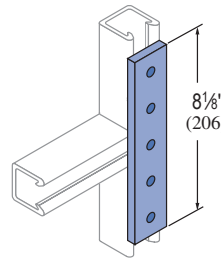

Wt/100 pcs: 32 Lbs (14.5 kg)

F20P-2508, F20V-2508

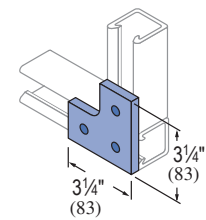

Wt/100 pcs: 17 Lbs (7.7 kg)

F20P-2510, F20V-2510

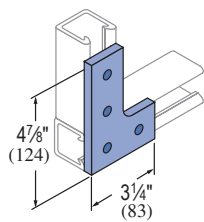

Wt/100 pcs: 25 Lbs (11.3 kg)

F20P-2512, F20V-2512

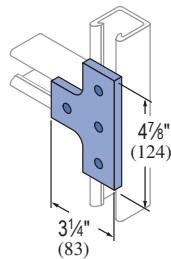

Wt/100 pcs: 26 Lbs (11.8 kg)

F20P-2514, F20V-2514

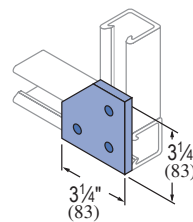

Wt/100 pcs: 20 Lbs (9.1 kg)

F20P-2516, F20V-2516

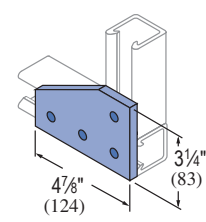

Wt/100 pcs: 32 Lbs (14.5 kg)

F20P-2518, F20V-2518

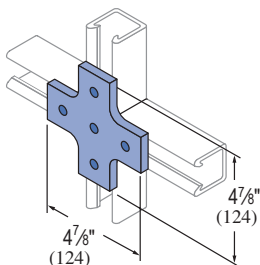

Wt/100 pcs: 33 Lbs (15.0 kg)

F20P-2520, F20V-2520

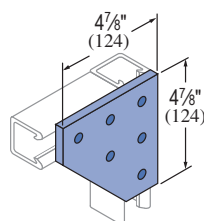

Wt/100 pcs: 45 Lbs (20.4 kg)

F20P-2522, F20V-2522

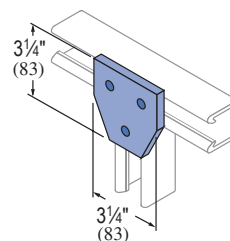

Wt/100 pcs: 21 Lbs (9.5 kg)

F20P-2524, F20V-2524

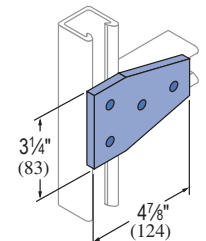

Wt/100 pcs: 32 Lbs (14.5 kg)



F20P-2526, F20V-2526

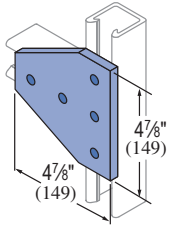

Wt/100 pcs: 45 Lbs (20.4 kg)

F20P-2528, F20V-2528

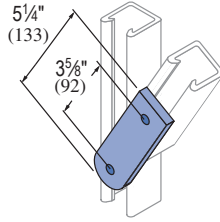

Wt/100 pcs: 20 Lbs (9.1 kg)

F20P-2530, F20V-2530



Wt/100 pcs: 50 Lbs (22.7 kg)

F20P-2534, F20V-2534

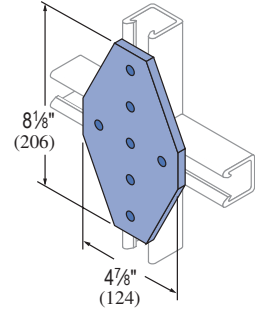

Wt/100 pcs: 77 Lbs (34.9 kg)

F20P-2540, F20V-2540

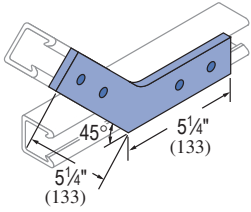

Wt/100 pcs: 41 Lbs (18.6 kg)

F50PU-2538

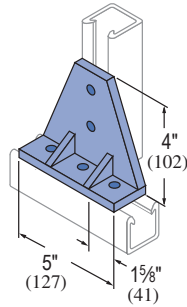

Wt/100 pcs: 57 Lbs (26.0 kg)

F50PU-2611

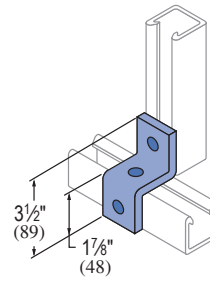

Wt/100 pcs: 9 Lbs (4.1 kg)

F50PU-2613

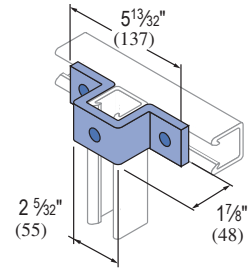

Wt/100 pcs: 16 Lbs (7.3 kg)

F50PU-1508 (1 1/2\"), F50PU-2008 (1 5/8\")

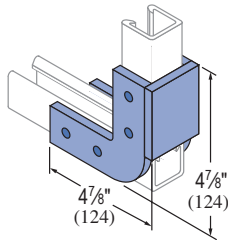

Wt/100 pcs: 27 Lbs (12.2 kg)

F50PU-2045 (1 5/8\")

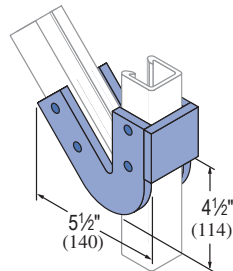

Wt/100 pcs: 35 Lbs (15.9 kg)

F50PU-2636

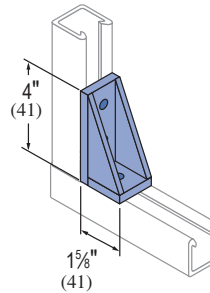

Wt/100 pcs: 14 Lbs (6.4 kg)

F50PU-2090 (1 5/8\")

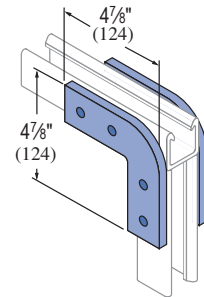

Wt/100 pcs: 35 Lbs (15.9 kg)

F50PU-2616

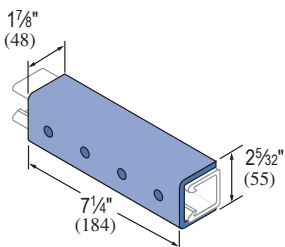

Wt/100 pcs: 51 Lbs (23.1 kg)

F20PU-5853 (1 5/8\"), F20PU-5855 (1 1/8\")

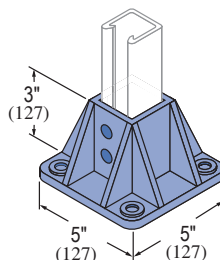

Wt/100 pcs: 71 Lbs (32.2 kg)

F20PU-5903 (3 1/4\"), F20PU-5905 (2 1/4\")

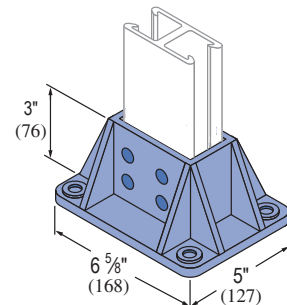

Wt/100 pcs: 86 Lbs (39.0 kg)

1 5/8" Channel
 Telestrut System
 Nuts & Hardware
 General Fittings
 Pipe/Conduit Supports
 Electrical Fittings
 Concrete Inserts
 1 1/4" Framing System
 1 3/16" Framing System
 Fiberglass System
 Special Metals
 PrimeAngle System
 Product Index

ADJUSTABLE PIPE CLAMPS

Unistrut Adjustable Pipe Clamps are manufactured from glass-reinforced polyurethane and are adjustable to accommodate a wide range of outside diameters. They can be utilized with a variety of piping systems including: PVC, fiberglass, copper, rigid steel conduit and PVC coated rigid steel conduit.

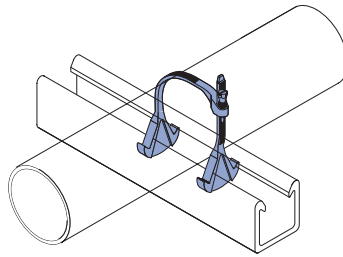

Care should be taken not to exceed 3 ft./lbs. of torque on the adjustable pipe straps.

| Part Number | O.D. Pipe Size (in.) | Design Load | | Torque Ft/Lbs (N·m) | Wt/100 pcs Lbs (kg) |
|-------------|----------------------|-----------------|-----------------|---------------------|---------------------|
| | | Type 1 Lbs (kN) | Type 2 Lbs (kN) | | |
| 200-3100 | ½ – 1½ | 135 (0.6) | 65 (0.3) | 0.8 (1) | 3 (1.4) |
| 200-3110 | 1½ – 2¼ | 135 (0.6) | 65 (0.3) | 3 (4) | 5 (2.3) |
| 200-3120 | 2¼ – 3¼ | 145 (0.6) | 70 (0.3) | 3 (4) | 5 (2.3) |
| 200-3130 | 3 – 4 | 215 (1.0) | 70 (0.3) | 3 (4) | 8 (3.6) |
| 200-3140 | 4 – 6½ | 215 (1.0) | 70 (0.3) | 3 (4) | 10 (4.5) |

*Design loads shown represent a 3:1 safety factor.

RIGID PIPE CLAMPS

| Part Number | PVC, Sch. 80 Design Loads* | | FRP Bolt | | Torque Ft/Lbs (N·m) | Wt/100 pcs Lbs (kg) |
|-------------|----------------------------------|---------------|-----------------|-----------------|---------------------|---------------------|
| | Nominal & Rigid Metal Size (in.) | In (mm) | Type 1 Lbs (kN) | Type 2 Lbs (kN) | | |
| FPCR-050 | ½ | 0.840 (21.3) | 225 (1.0) | 90 (0.4) | 3 (4) | 3 (1.4) |
| FPCR-075 | ¾ | 1.050 (26.7) | 225 (1.0) | 90 (0.4) | | 3 (1.4) |
| FPCR-100 | 1 | 1.315 (33.4) | 225 (1.0) | 90 (0.4) | | 4 (1.8) |
| FPCR-125 | 1¼ | 1.660 (42.2) | 225 (1.0) | 90 (0.4) | | 5 (2.3) |
| FPCR-150 | 1½ | 1.900 (48.3) | 225 (1.0) | 90 (0.4) | | 5 (2.3) |
| FPCR-200 | 2 | 2.375 (60.3) | 225 (1.0) | 90 (0.4) | | 5 (2.3) |
| FPCR-250 | 2½ | 2.875 (73.0) | 225 (1.0) | 90 (0.4) | | 7 (3.2) |
| FPCR-300 | 3 | 3.500 (88.9) | 225 (1.0) | 90 (0.4) | | 10 (4.5) |
| FPCR-400 | 4 | 4.500 (114.3) | 300 (1.3) | 125 (0.6) | | 12 (5.4) |
| FPCR-600 | 6 | 6.625 (168.3) | 300 (1.3) | 125 (0.6) | | 15 (6.8) |
| FPCR-800 | 8 | 8.625 (219.1) | 300 (1.3) | 125 (0.6) | 18 (8.1) | |

*Design loads shown represent a 3:1 safety factor.

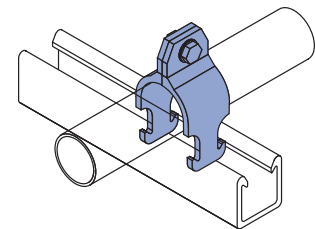

Rigid Pipe Clamps resemble the more traditional style of pipe clamps and are sized based on the pipe inside diameter or nominal size. Polyurethane clamps are recommended for applications up to 160°F. For high temperature applications (up to 230°F). Care should be taken not to exceed the recommended torque values of the rigid pipe clamps. Material: glass-reinforced polyurethane.

TWO HOLE PIPE STRAPS

| Part No. | Dim. A In (mm) | Dim. B In (mm) | Bolt Size (in.) | Material Thick. In (mm) | Design Load | | Torque Ft/Lbs (N·m) | Wt/100 pcs Lbs (kg) |
|----------|------------------|------------------|-----------------|-------------------------|-----------------|-----------------|---------------------|---------------------|
| | | | | | Type 1 Lbs (kN) | Type 2 Lbs (kN) | | |
| FPS200 | 2.375 60.33 | 6.375 161.93 | ½ | ¼ 6.4 | 135 0.60 | 50 0.22 | 4 5 | 14 6.4 |
| FPS250 | 2.875 73.03 | 6.875 174.63 | ½ | ¼ 6.4 | 135 0.60 | 50 0.22 | 4 5 | 17 7.7 |
| FPS300 | 3.500 88.90 | 7.500 190.50 | ½ | ¼ 6.4 | 135 0.60 | 50 0.22 | 4 5 | 20 9.1 |
| FPS350 | 4.000 101.60 | 8.000 203.20 | ½ | ¼ 6.4 | 135 0.60 | 50 0.22 | 4 5 | 33 15.0 |
| FPS400 | 4.500 114.30 | 8.500 215.90 | ½ | ¼ 6.4 | 175 0.78 | 60 0.27 | 4 5 | 23 10.4 |
| FPS500 | 5.563 141.30 | 9.563 242.90 | ½ | ¼ 6.4 | 175 0.78 | 60 0.27 | 4 5 | 39 17.7 |
| FPS600 | 6.625 168.28 | 10.625 269.88 | ½ | ¼ 6.4 | 175 0.78 | 60 0.27 | 4 5 | 39 17.7 |
| FPS800 | 8.625 219.08 | 12.625 320.68 | ½ | ¼ 6.4 | 225 1.00 | 125 0.56 | 4 5 | 51 23.1 |
| FPS1000 | 10.750 273.05 | 15.750 400.05 | ¾ | ¼ 6.4 | 225 1.00 | 125 0.56 | 10 14 | 77 34.9 |
| FPS1200 | 12.750 323.85 | 16.250 412.75 | ¾ | ¼ 6.4 | 225 1.00 | 125 0.56 | 10 14 | 83 37.6 |
| FPS1400 | 14.000 355.60 | 18.000 457.20 | ¾ | ¾ 9.5 | 250 1.11 | 150 0.67 | 10 14 | 125 56.7 |
| FPS1600 | 16.000 406.40 | 20.000 508.00 | ¾ | ¾ 9.5 | 250 1.11 | 150 0.67 | 10 14 | 143 64.9 |
| FPS1800 | 18.000 457.20 | 23.000 584.20 | ¾ | ¾ 9.5 | 250 1.11 | 150 0.67 | 10 14 | 160 72.6 |

*Design loads shown represent a 3:1 safety factor.

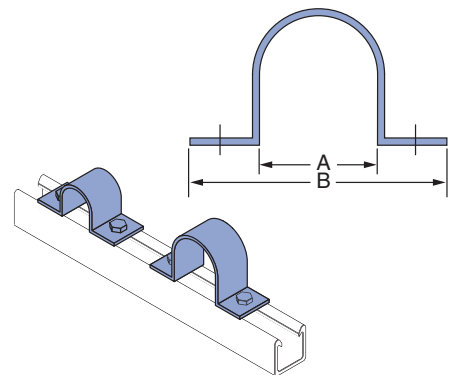

Two Hole Pipe Straps are designed for use in securing pipe, conduit and ducts to Channel. Two hole fiberglass straps can also be used independently from the channel for surface mounting. All sizes of the straps are suitable for load bearing applications.

Material: fire-retardant, glass-reinforced polyester resin.

For extreme chemical environments, the straps can be manufactured from vinyl ester resin. Larger diameter straps for special applications are also available. Contact the factory for pricing and availability of vinyl ester and large diameter straps. Two hole pipe straps should not be torqued above recommended values.

Notes:

- (1) Bolts and channel nuts are sold separately.
- (2) When bolting onto 1½" channel a 1¼" long bolt is req'd.



MOLDED CLEVIS HANGERS

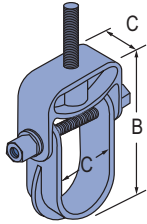

Material: glass-reinforced polyurethane.

*Design load values shown represent a 3:1 safety factor.

| Part Number | Nominal Diameter In (mm) | Max. Pipe O.D. In (mm) | "A" Dim. In (mm) | "B" Dim. In (mm) | "C" Dim. In (mm) | Hanger Rod In (mm) | Load* Lbs (kN) | Wt/100 pcs Lbs (kg) |
|-------------|-----------------------------|---------------------------|---------------------|---------------------|---------------------|-----------------------|-------------------|------------------------|
| FCVHPU-100 | 1/2 - 1 | 1 | 1.500 | 4.25 | 1.25 | 1/2 | 670 | 29 |
| | 13 - 25 | 25 | 38.1 | 108 | 32 | 13 | 2.98 | 13.2 |
| FCVHPU-150 | 1/4 - 1 1/2 | 1 1/2 | 2.000 | 5.14 | 1.25 | 1/2 | 670 | 40 |
| | 32 - 38 | 38 | 50.8 | 131 | 32 | 13 | 2.98 | 18.1 |
| FCVHPU-200 | 1 1/2 - 2 | 2 | 2.500 | 6.52 | 1.25 | 1/2 | 730 | 43 |
| | 38 - 51 | 51 | 63.5 | 166 | 32 | 13 | 3.25 | 19.5 |
| FCVHPU-400 | 2 1/2 - 4 | 4 | 5.125 | 10.00 | 1.50 | 1/2 | 1,150 | 129 |
| | 64 - 102 | 102 | 130.2 | 254 | 38 | 13 | 5.12 | 58.5 |
| FCVHPU-600 | 4 1/2 - 6 | 6 | 6.750 | 12.33 | 1.50 | 1/2 | 1,170 | 168 |
| | 114 - 152 | 152 | 171.5 | 313 | 38 | 13 | 5.20 | 76.2 |

FABRICATED CLEVIS HANGERS

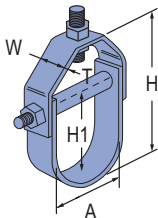

Material: glass-reinforced polyester resin.

*Design load values shown represent a 3:1 safety factor.

| Part Number | Size Range In (mm) | Dimensions - In (mm) | | | | | Hanger Rod In (mm) | Trans Rod In (mm) | Spreader Rod O.D. In (mm) | Loads* Lbs (kN) | Wt/100 pcs Lbs (kg) |
|-------------|-----------------------|----------------------|--------|--------|-------|-----|-----------------------|----------------------|------------------------------|--------------------|------------------------|
| | | A | T | H | H1 | W | | | | | |
| F100-1500 | 1-1 1/2 | 1/8 | 2 3/4 | 1 1/8 | 1 1/2 | 1/2 | 3/8 | 1/2 | 60 | 21 | |
| | 25 - 38 | 3 | 70 | 48 | 38 | 13 | 10 | 13 | 0.27 | 9.5 | |
| F100-1501 | 1 1/2 - 2 | 1/8 | 3 1/2 | 2 3/8 | 1 1/2 | 1/2 | 3/8 | 1/2 | 60 | 25 | |
| | 38 - 51 | 3 | 89 | 60 | 38 | 13 | 10 | 13 | 0.27 | 11.3 | |
| F100-1502 | 2 - 2 1/2 | 1/8 | 4 3/4 | 3 | 2 | 1/2 | 3/8 | 1/2 | 90 | 55 | |
| | 51 - 67 | 3 | 121 | 76 | 51 | 13 | 10 | 13 | 0.40 | 24.9 | |
| F100-1503 | 2 1/2 - 3 1/4 | 1/8 | 5 1/2 | 3 3/8 | 2 | 1/2 | 3/8 | 1/2 | 120 | 57 | |
| | 64 - 83 | 3 | 140 | 92 | 51 | 13 | 10 | 13 | 0.53 | 25.9 | |
| F100-1504 | 3 - 3 3/4 | 1/8 | 7 | 4 1/4 | 2 | 5/8 | 3/8 | 1/2 | 160 | 61 | |
| | 76 - 98 | 3 | 178 | 108 | 51 | 16 | 10 | 13 | 0.71 | 27.7 | |
| F100-1505 | 4 - 5 1/2 | 13/16 | 8 1/2 | 5 3/8 | 2 | 5/8 | 3/8 | 1/2 | 250 | 82 | |
| | 102 - 130 | 21 | 216 | 143 | 51 | 16 | 10 | 13 | 1.11 | 37.2 | |
| F100-1506 | 6 - 7 1/2 | 13/16 | 10 7/8 | 7 1/2 | 3 | 5/8 | 3/8 | 1/2 | 300 | 136 | |
| | 152 - 181 | 21 | 276 | 191 | 76 | 16 | 10 | 13 | 1.33 | 61.7 | |
| F100-1507 | 8 - 9 1/4 | 1/4 | 14 | 9 3/4 | 3 | 5/8 | 3/8 | 1/2 | 350 | 189 | |
| | 203 - 235 | 6 | 356 | 248 | 76 | 16 | 10 | 13 | 1.56 | 85.7 | |
| F100-1508 | 10 - 11 3/4 | 1/4 | 18 | 12 | 4 | 5/8 | 1/2 | 3/4 | 450 | 333 | |
| | 254 - 289 | 6 | 457 | 305 | 102 | 16 | 13 | 19 | 2.00 | 151.0 | |
| F100-1509 | 12 - 13 1/2 | 1/4 | 21 1/2 | 14 1/8 | 5 | 5/8 | 1/2 | 3/4 | 600 | 350 | |
| | 305 - 343 | 6 | 546 | 359 | 127 | 16 | 13 | 19 | 2.67 | 158.8 | |
| F100-1510 | 14 - 15 3/4 | 1/4 | 24 1/2 | 16 1/2 | 5 | 3/4 | 1/2 | 3/4 | 700 | 872 | |
| | 356 - 400 | 6 | 622 | 419 | 127 | 19 | 13 | 19 | 3.11 | 395.5 | |
| F100-1511 | 16 - 18 | 3/8 | 27 3/8 | 19 1/2 | 6 | 3/4 | 3/4 | 1 | 750 | 1,023 | |
| | 406 - 457 | 10 | 695 | 495 | 152 | 19 | 19 | 25 | 3.34 | 464.0 | |
| F100-1512 | 19 - 21 | 3/8 | 34 1/2 | 22 1/2 | 6 | 3/4 | 3/4 | 1 | 800 | 1,673 | |
| | 483 - 533 | 10 | 876 | 572 | 152 | 19 | 19 | 25 | 3.56 | 758.9 | |
| F100-1513 | 21 - 22 | 1/2 | 35 1/2 | 24 | 6 | 3/4 | 3/4 | 1 | 850 | 2,323 | |
| | 533 - 559 | 13 | 902 | 610 | 152 | 19 | 19 | 25 | 3.78 | 1,053.7 | |
| F100-1514 | 22 - 24 | 1/2 | 41 | 28 | 6 | 3/4 | 3/4 | 1 | 900 | 2,973 | |
| | 533 - 610 | 13 | 1,041 | 711 | 152 | 19 | 19 | 25 | 4.00 | 1,348.5 | |

F200-4101

UNISERT CHANNEL INSERT

Unisert is a polyurethane nonmetallic insert which can be used with standard cable ties for securing tubing, conduit and cables to standard metal channels. The Unisert works with all 1 1/2" channels that are 13/16" deep or more. One size fits 12, 14 and 16 metal gauge channels.

Note: For use only with metallic channel.

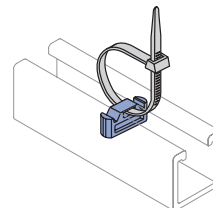

Wt/100 pcs: 1.0 Lbs (.5 kg)

1 1/2" Channel
 Telesstrut System
 Hardware
 General Fittings
 Pipe/Conduit Supports
 Electrical Fittings
 Concrete Inserts
 1 1/4" Framing System
 1 3/16" Framing System
 Fiberglass System
 Special Metals
 PrimeAngle System
 Product Index

F375PU & F500PU

MOLDED BEAM CLAMPS

Material: glass-reinforced polyurethane

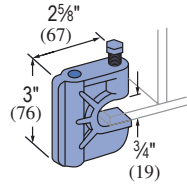

| Assembly Part Number | Size In | Thread Shear Lbs (kN)* | Torque Ft/Lbs (N•m) | Wt/100 pcs Lbs (kg) |
|----------------------|---------|------------------------|---------------------|---------------------|
| F375PU-BC | 3/8 | 400 1.78 | 10 14 | 30 13.6 |
| F500PU-BC | 1/2 | 400 1.78 | 10 14 | 30 13.6 |

*Design load values shown represent a 3:1 safety factor.

FRGBC

MOLDED BEAM CLAMP ASSEMBLY

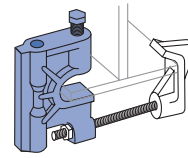

F375PU-BCCLP (3/8") Beam Clip Only

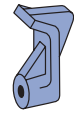

Note: Beam clamp clip must be purchased separately. Illustration purpose only

Material: glass-reinforced polyurethane.

| Part Number | Size In | Thread Shear Lbs (kN)* | Torque Ft/Lbs (N•m) | Wt/100 pcs Lbs (kg) |
|-------------|---------|------------------------|---------------------|---------------------|
| FRGBC-1 | 3/8 | 500 2.22 | 10 14 | 43 19.5 |
| FRGBC-2 | 1/2 | 500 2.22 | 10 14 | 43 19.5 |
| FRGBC-3 | 5/8 | 500 2.22 | 10 14 | 43 19.5 |

*Design load values shown represent a 3:1 safety factor.

POWER-RACK STANCHIONS

The Power-Rack Stanchion is made entirely from glass-reinforced nylon, these stanchions offer greater corrosion resistance than classical metal stanchions. The interlocking design allows the arm to "lock" into nine different levels on the 14 1/4" stanchions and fourteen on the 17 1/2" stanchion. Glass-reinforced polyurethane stanchions are available as a special order. Contact Unistrut for pricing and availability.

Dimensions – The stanchion back has 9/16" x 15/16" holes to accept fasteners for mounting. There are two mounting holes in the 21 3/8" long stanchion and three in the 33 5/16" long stanchion. Thickness at the slotted mounting holes is 1 1/8". The mounting holes are spaced on 12" centers and require 1/2" diameter fasteners.

Installation – The Stanchions can be anchored into existing concrete structures using any industrial anchoring system. For new concrete structures, the Stanchions can be mounted to fiberglass concrete embedment channel and attached with 1/2" channel nuts and 1/2"x 3" Fiberfast Bolts.

Fire Retardance – Power-Rack materials meet or exceed the requirements of UL94 HB.

Loading – The recommended allowable loads on Power-Rack Stanchions vary depending upon the position of the arm. Use these guidelines for a safe, reliable installation:

- Total load on any one arm should not exceed 800 lbs.
- The sum of the loads on an arm multiplied by their distances to the wall stanchion should not exceed 1200 in./lbs.

Example: A cable weighing 200 lbs. is positioned on an arm at a distance of 5" from the wall stanchion.

If the total load is less than 800 lbs and the sum of the load multiplied by their distances to the wall stanchion does not exceed 1200 in./lbs., then the system is adequate. In this case,

Total load (200<800 lbs) = OK
Tot. moment (200x5 in. = 1000<1200 in./lbs.) = OK

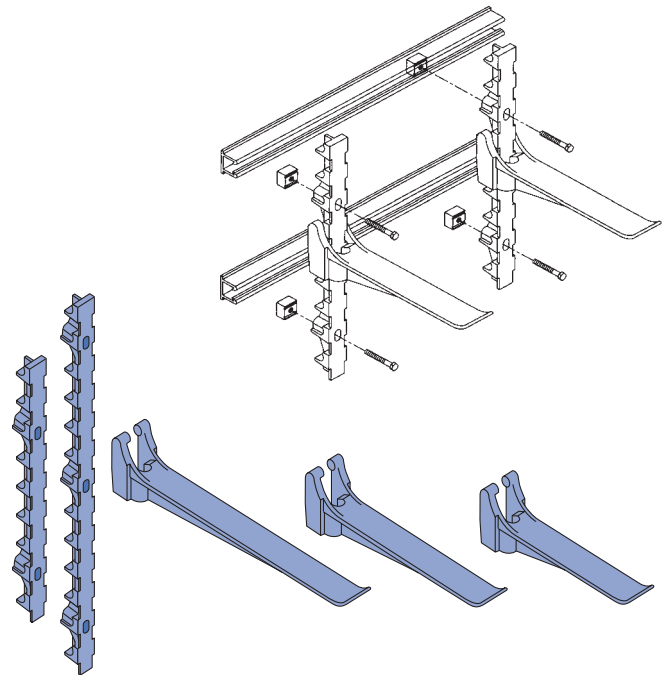

| Part No. | Description | Size In (mm) | Wt/100 pcs Lbs (kg) | Load (lbs.)* Lbs (kN) |
|------------|-------------|----------------|---------------------|-----------------------|
| F20N-ARM08 | Arm | 8 203 | 100 45.4 | 800 3.56 |
| F20N-ARM14 | Arm | 14 1/4 362 | 116 52.6 | 800 3.56 |
| F20N-ARM17 | Arm | 17 1/2 445 | 145 65.8 | 800 3.56 |
| F20N-ARM23 | Arm | 23 7/8 606 | 186 84.4 | 800 3.56 |
| F20N-STA21 | Stanchion | 21 3/8 543 | 149 67.6 | N/A |
| F20N-STA33 | Stanchion | 33 5/16 846 | 231 104.8 | N/A |

*Design load values shown represent a 3:1 safety factor.



FIBERGLASS CLAMPS DESIGN LOAD INFORMATION

There are two types of piping system loadings, overhead (Type 1) and vertical (Type 2) as described below. All pipe straps and clamps show the recommended loading for both types of loading.

Type 1 Overhead Design Load

The design load shown represents pipes supported below the strut. The design loads shown are based on a minimum ultimate failure safety factor of 3:1.

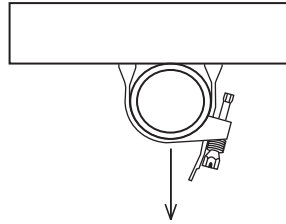

Type 2 Vertical Design Load

The design loading shown can be achieved with the addition of a vertical stop lock assembly (Part #F200-4219) installed directly beneath the pipe clamp. The adjacent illustration shows how the vertical stop lock assembly provides additional support for pipe and how it can be used to achieve full Type 2 design loads.

Design loads are based on a minimum clamp slip safety factor of 3:1. It is recommended that stop lock assemblies be used for all vertical pipe support applications.

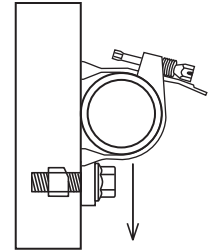

CHEMICAL COMPATIBILITY TABLE

| Chemical | Series | | | | | | | | | |
|---|-----------|-------|------------|-------|-------------|-------|------|-------|-------|-------|
| | E | | P | | V | | PU | | N | |
| | Rigid PVC | | Poly/Glass | | Vinyl/Glass | | Poly | | Nylon | |
| | 70° | 160°F | 70° | 160°F | 70° | 160°F | 70° | 160°F | 70° | 160°F |
| Acetic Acid, Up to 50% | R | R | R | R | R | R | R | - | nr | nr |
| Acetone, Up to 10% | nr | nr | nr | nr | nr | nr | R | - | R | R |
| Aluminum Hydroxide | R | R | R | R | R | R | R | - | nr | nr |
| Ammonium Hydroxide (Aqueous Ammonia), Up to 5% | R | R | nr | nr | R | R | R | - | - | - |
| Ammonium Hydroxide (Aqueous Ammonia), Up to 10% | R | R | nr | nr | R | 150° | R | - | - | - |
| Ammonium Hydroxide, Up to 20% | R | R | nr | nr | R | 150° | R | - | - | - |
| Ammonium Nitrate | R | nr | R | R | R | R | R | - | - | - |
| Ammonium Phosphate | R | R | R | nr | R | R | R | - | - | - |
| Ammonium Sulfide, saturated | R | R | nr | nr | R | 120° | R | - | - | - |
| Aqua Regia, fumes | nr | nr | nr | nr | R | 150° | nr | - | - | - |
| Benzene | nr | nr | nr | nr | nr | nr | R | R | - | R |
| Benzoic Acid | R | R | R | R | R | R | R | - | - | - |
| Bromine, wet gas | R | nr | nr | nr | R | 100° | - | - | - | - |
| Butylene Glycol, Up to 100% | R | R | R | R | R | R | R | - | R | R |
| Butyric Acid, Up to 50% | nr | nr | R | R | R | R | R | - | - | - |
| Calcium Hydroxide | R | R | R | nr | R | R | R | - | - | - |
| Calcium Hypochlorite | R | R | R | nr | R | R | R | - | nr | nr |
| Chlorine, Dry Gas | nr | nr | nr | nr | R | R | - | - | - | - |
| Chlorine, Wet Gas | nr | nr | nr | nr | R | R | - | - | - | - |
| Chlorine, Liquid | nr | nr | nr | nr | nr | nr | - | - | - | - |
| Chlorine, Water | nr | nr | R | R | R | R | R | - | nr | nr |
| Chromic Acid, Up to 5% | R | R | nr | nr | R | R | - | - | R | R |
| Copper Chloride | R | R | R | R | R | R | R | - | - | - |
| Copper Cyanide | R | R | R | nr | R | R | R | - | - | - |
| Copper Fluoride | R | R | R | nr | R | R | R | - | - | - |
| Copper Nitrate | R | R | R | R | R | R | R | - | - | - |
| Copper Sulfate | R | R | R | R | R | R | R | - | - | - |
| Dechlorinated Brine Storage | R | R | - | - | R | R | R | - | - | - |
| Esters, Fatty Acid | nr | nr | R | R | R | R | R | - | - | - |
| Ferric Chloride | R | R | R | R | R | R | R | - | - | - |
| Ferrous Chloride | R | R | R | R | R | R | R | - | - | - |
| Fluoboric Acid | R | R | R | 120° | R | R | - | - | - | - |
| Fluosilicic Acid, Up to 10% | nr | nr | nr | nr | R | R | - | - | nr | nr |
| Fluosilicic Acid, Up to 32% | nr | nr | nr | nr | R | 100° | - | - | - | - |

15/16" Channel
 Telestrut System
 Nuts & Hardware
 General Fittings
 Pipe/Conduit Supports
 Electrical Fittings
 Concrete Inserts
 1 1/4" Framing System
 1 3/16" Framing System
 Fiberglass System
 Special Metals
 PrimeAngle System
 Product Index

CHEMICAL COMPATIBILITY TABLE

| Chemical | Series | | | | | | | | | |
|--------------------------------|-----------|-------|------------|-------|-------------|-------|------|-------|-------|-------|
| | E | | P | | V | | PU | | N | |
| | Rigid PVC | | Poly/Glass | | Vinyl/Glass | | Poly | | Nylon | |
| | 70° | 160°F | 70° | 160°F | 70° | 160°F | 70° | 160°F | 70° | 160°F |
| Formic Acid, Up to 10% | R | R | nr | nr | R | R | R | - | nr | nr |
| Formic Acid, Up to 50% | R | R | nr | nr | R | 100° | R | - | - | - |
| Gasoline, Aviation | R | nr | R | nr | R | R | R | - | - | - |
| Green Liquor, Pulp Mill | R | R | - | - | R | R | - | - | - | - |
| Hydrochloric Acid, Up to 15% | R | R | R | nr | R | R | R | - | - | - |
| Hydrochloric Acid, Up to 37% | R | R | R | nr | R | R | R | - | - | - |
| Hydrofluoric Acid, Up to 10% | R | R | nr | nr | R | 150° | - | - | - | - |
| Hydrofluoric Acid, Up to 20% | R | nr | nr | nr | R | 100° | - | - | - | - |
| Hydrogen Chloride Wet Gas | nr | nr | R | nr | R | R | nr | - | - | - |
| Hydrogen Sulfide Wet Gas | R | R | R | nr | R | R | R | - | - | - |
| Lactic Acid | R | R | R | nr | R | R | R | - | - | - |
| Lead Nitrate | R | R | - | - | R | R | R | - | - | - |
| Magnesium Hydroxide | R | R | nr | nr | R | R | R | - | R | R |
| Nickel Sulfate | R | R | nr | nr | R | R | R | - | - | - |
| Nitric Acid, Up to 5% | R | R | nr | nr | R | 150° | R | - | - | - |
| Nitric Acid, Up to 35% | R | R | nr | nr | R | 150° | R | - | - | - |
| Nitric Acid, Vapor | R | R | nr | nr | R | R | R | - | - | - |
| Perchloric Acid, Up to 10% | nr | nr | nr | nr | R | 150° | R | - | nr | nr |
| Pickling Liquids, 3-5% H2SO4 | R | R | R | R | R | R | R | - | - | - |
| Phosphoric Acid | R | R | nr | nr | R | R | R | - | nr | nr |
| Super or Poly (115%, P20%) | R | R | nr | nr | R | R | R | - | - | - |
| Vapor or Condensate | R | R | nr | nr | R | R | R | - | - | - |
| Potassium Chloride | R | R | R | R | R | R | R | - | - | - |
| Potassium Nitrate | R | R | R | R | R | R | R | - | - | - |
| Potassium Persulfate | R | R | nr | nr | R | R | R | - | - | - |
| Silver Cyanide, Up to 5% | R | R | nr | nr | R | R | R | - | - | - |
| Sodium Hydroxide, Up to 25% | R | R | nr | nr | R | 150° | R | - | - | - |
| Sodium Hydroxide, Up to 50% | R | R | nr | nr | R | 180° | R | - | R | R |
| Sodium Hypochlorite, Up to 15% | R | R | nr | nr | R | 150° | R | - | nr | nr |
| Sodium Nitrate | R | R | R | R | R | R | R | - | - | - |
| Sodium Sulfate | R | R | R | nr | R | R | R | - | - | - |
| Sodium Sulfide | R | R | nr | nr | R | R | R | - | - | - |
| Sulfuric Acid, Up to 25% | R | R | R | R | R | R | R | - | nr | nr |
| Sulfuric Acid, Up to 70% | R | R | nr | nr | R | R | R | - | nr | nr |
| Sulfuric Acid, Up to 75% | nr | nr | nr | nr | R | 120° | R | - | nr | nr |
| Sulfuric Acid, Up to 80% | nr | nr | nr | nr | nr | nr | nr | - | nr | nr |
| Sulfuric Acid, Vapor | R | R | R | nr | R | R | R | - | - | - |
| Trichlorethylene, Fumes | nr | nr | nr | nr | R | 120° | R | - | - | - |
| Trisodium Phosphate | R | R | R | nr | R | R | R | - | - | - |
| Urea | R | R | R | nr | R | 150° | R | - | R | R |
| Vegetable Oils | R | R | R | R | R | R | R | - | R | R |
| Vinegar | R | R | R | R | R | R | R | R | R | R |
| White Liquor, Pulp Mill | R | R | - | - | R | R | R | - | - | - |

Note

The recommendations contained in this table are made without guarantee of representation as to results. Since the actual use by others is beyond our control, no guarantee, expressed or implied, is made by Unistrut as to effects of such use or results to be obtained nor does Unistrut assume any liability arising out of the use by others of the products referenced in this table. Nor is the information herein to be construed as absolutely complete since additional information may be needed or desirable when particular or exceptional conditions or circumstances exist or because of applicable laws or government regulations. We suggest that you evaluate these recommendations and suggestions in your own laboratory prior to use. Our responsibility for claims arising from breach of warranty, negligence, or otherwise is limited to the purchase price of the material.

Legend

“nr” - “Not Recommended” for use
 “R” - “Recommended”
 “-” - no information available

15/16" Channel
 Telestrut System
 Nuts & Hardware
 General Fittings
 Pipe/Conduit Supports
 Electrical Fittings
 Concrete Inserts
 1 1/4" Framing System
 1 3/16" Framing System
 Fiberglass System
 Special Metals
 PrimeAngle System
 Product Index



FIBERGLASS SPECIFICATIONS

1.0 SCOPE

- 1.1 This specification covers the requirements for the Unistrut Nonmetallic Channel Framing System.

2.0 MATERIAL

- 2.1 FRP channel shall be of pultruded glass-reinforced polyester or vinyl ester resin having the physical property values listed in this catalog.
- 2.2 Some accessories shall be of injection molded, 40% long glass fiber reinforced polyurethane, or nylon.

3.0 COMPOSITION

- 3.1 Glass-reinforced channel shall have a synthetic surfacing veil applied on exterior surfaces to improve weatherability and inhibit ultraviolet degradation. An ultraviolet stabilizer shall be incorporated in the resin formulation to further inhibit ultraviolet degradation.

4.0 STRUCTURAL DESIGN

- 4.1 Channel shall incorporate Unistrut's patented flange profile design which allows full and positive interlocking contact of channel accessories and prohibits premature flange failure from torqued accessories.
- 4.2 Channel profile dimensions shall be:
- $$1\frac{5}{8}" \times 1\frac{5}{8}" \times \frac{1}{4}" \text{ or } 1\frac{1}{2}" \times 1\frac{1}{8}" \times \frac{1}{8}."$$
- 4.3 All $1\frac{5}{8}" \times 1\frac{5}{8}"$ channel profiles shall have a minimum pull out resistance of 1,000 pounds when load is applied over a $\frac{3}{8}"$ long section of the inside flanges.
- 4.4 Channel section lengths shall be supplied in 10' or 20' lengths ($\pm\frac{1}{8}"$).
- 4.5 Universal Pipe Clamps shall have full interlocking contact with interior channel flanges to maximize pull-out resistance and be adjustable to accommodate a minimum $\frac{3}{4}"$ variance in piping or conduit O.D. sizes.

5.0 STANDARDS

- 5.1 Glass-reinforced channels covered in this specification shall have a flame spread rating of 25 or less when tested per ASTM E84 and meet the requirements of UL 94V0 thereby qualifying them as Class 1 material in the Uniform Building Code.
- 5.2 Glass-reinforced channels covered in this specification shall comply with the requirements of ASTM D 3917 and ASTM D 4385 which govern the dimensional tolerance and visual defects of pultruded shapes.

6.0 GENERAL

- 6.1 Unistrut nonmetallic Channel Framing shall be furnished as a system which includes all the necessary fasteners, channel splice plates, brackets, sealants, hangers, pipe clamps, etc.
- 6.2 Nonmetallic fasteners shall be manufactured from long glass fiber reinforced polyurethane to ensure maximum strength and corrosion resistance.
- 6.3 All components of the Unistrut Channel Framing System shall be nonmetallic except where type 316 stainless steel hardware is used as part of the assembly.
- 6.4 The manufacturer shall not have had less than 10 years experience in manufacturing strut systems.
- 6.5 All products are manufactured in the United States of America.

Stainless Steel 185-186

Aluminum 187-188

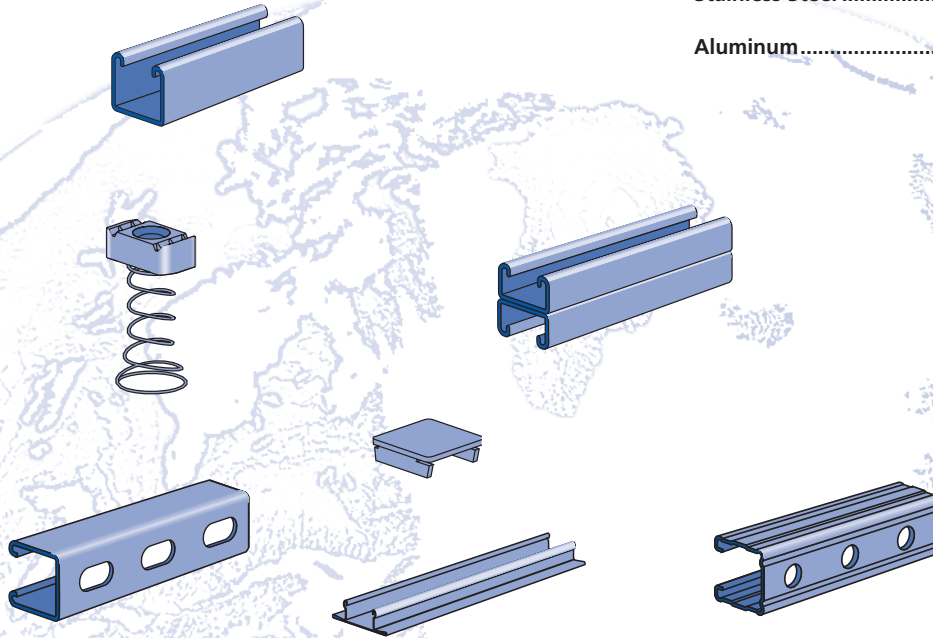

MATERIAL

STAINLESS STEEL

- Channels: ASTM A 240 (Type 304)
- Sintered nuts: ASTM B783 (Type 316N2-33)
- Fittings:
 - ASTM A240 (Type 304) or ASTM A276 (Type 304)
 - Type 316 stainless also available for most products.
 - Contact factory for specific material availability.

ALUMINUM

- Channels (Extruded): ASTM B221 (Type 6063-T6)
- Fittings: ASTM B209 (Type 1100F or Type 5052-H32)
- Nuts: ASTM B221 (Type 6063-T5)

LOAD DATA (BEAM & COLUMN)

To determine maximum allowable beam and column load for channels in this section, multiply the load data in the appropriate mild steel channel sections of this catalog by the following factors:

| Channel Material | Beam Load % Factor | Column Load % Factor |
|-------------------|--------------------|----------------------|
| Extruded Aluminum | 33% | 33% |
| Stainless Steel | 100% | 100% |

LOAD DATA (SLIP & PULL OUT)

EXTRUDED ALUMINUM

To determine nut slip resistance, multiply load data for appropriate nut by 75%. To determine nut pull-out load, multiply load data for appropriate nut by 50%.

STAINLESS STEEL

For design assistance, consult Unistrut customer engineering.

PRODUCT AVAILABILITY

Most fittings and channels shown in this catalog, are available in aluminum or stainless steel. Consult factory for ordering information.

DIMENSIONS

Imperial dimensions are illustrated in inches. Metric dimensions are shown in parenthesis or as noted. Unless noted, all metric dimensions are in millimeters and rounded to one decimal place.



P1000 Series (12 gauge)



P1000 SS
Pg 185



P1001 SS
Pg 185

P1100 Series (14 gauge)



P1100 SS
Pg 185



P1101 SS
Pg 185

P3000 Series (12 gauge)



P3000 SS
Pg 185

P3300 Series (12 gauge)



P3300 SS
Pg 185



P3301 SS
Pg 185

P4000 Series (16 gauge)



P4000 SS
Pg 185

P6000 Series (19 gauge)



P6000 SS
Pg 185

P7000 Series (19 gauge)



P7000 SS
Pg 185

Closure Strips and End Caps



P1184 SS
Pg 186



P3184 EA
Pg 186



P1280 EA, P4280 EA,
P5580 EA Pg 188

Stainless Steel Channel Nuts



P1006 U - P1010U
Pg 186



P4006 U - P4010
Pg 186



P5506 U - P5510U
Pg 186



P4010 UT
Pg 186



A1006 SS, A1008 SS
Pg 186



A4006 SS, A4008 SS
Pg 186

Extruded Aluminum Channels



P1000 EA
Pg 187



P1001 EA
Pg 187



P4000 EA
Pg 187



P4001 EA
Pg 187



P5500 EA
Pg 187



A1000 EA
Pg 187



A4000 EA
Pg 187



A4001 EA
Pg 188



P6000 EA
Pg 188



P6001 EA
Pg 188



P7000 EA
Pg 188



P7001 EA
Pg 188

Product Index
 PrimeAngle System
 Special Metals
 Fiberglass System
 1 3/16" Framing System
 1 1/4" Framing System
 Concrete Inserts
 Electrical Fittings
 Pipe/Conduit Supports
 General Fittings
 Nuts & Hardware
 Telesruct System
 1 5/8" Channel

P1000 SERIES

P1000 SS

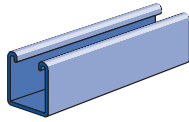

Wt/100 Ft: 190 Lbs (283 kg/100m)

P1001 SS

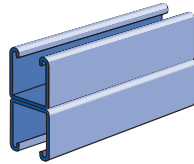

Wt/100 Ft: 380 Lbs (566 kg/100m)

P1000HS SS

9/16" (14) Dia. Holes
1 7/8" (48) on Center

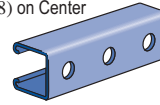

Wt/100 Ft: 185 Lbs (275 kg/100m)

P1000T SS

Slots are
1 1/8" (29) x 9/16" (14)
2" (51) on Center

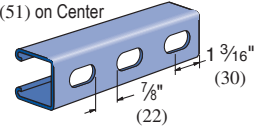

Wt/100 Ft: 185 Lbs (275 kg/100m)

P1100 SERIES

P1100 SS

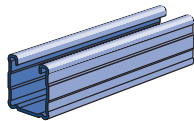

Wt/100 Ft: 142 Lbs (211 kg/100m)

P1101 SS

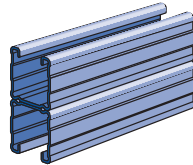

Wt/100 Ft: 284 Lbs (422 kg/100m)

P1100HS SS

9/16" (14) Dia. Holes
1 7/8" (48) on Center

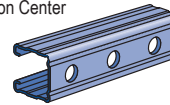

Wt/100 Ft: 136 Lbs (202 kg/100 m)

P1100T SS

Slots are
1 1/8" (29) x 9/16" (14)
2" (51) on Center

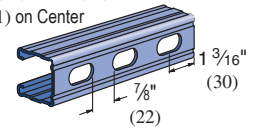

Wt/100 Ft: 136 Lbs (202 kg/100m)

P3000 SERIES

P3000 SS

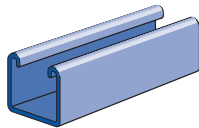

Wt/100 Ft: 170 Lbs (253 kg/100m)

P3000HS SS

9/16" (14) Dia. Holes
1 7/8" (48) on Center

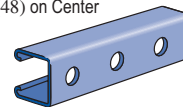

Wt/100 Ft: 165 Lbs (112 kg/100m)

P3000T SS

Slots are
1 1/8" (29) x 9/16" (14)
2" (51) on Center

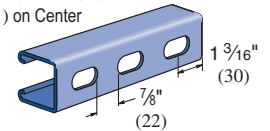

Wt/100 Ft: 165 Lbs (112 kg/100m)

P3300 SERIES

P3300 SS

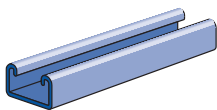

Wt/100 Ft: 135 Lbs (201 kg/100m)

P3301 SS

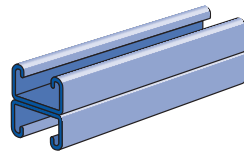

Wt/100 Ft: 270 Lbs (402 kg/100m)

P3300HS SS

9/16" (14) Dia. Holes
1 7/8" (48) on Center

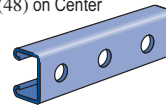

Wt/100 Ft: 130 Lbs (193 kg/100m)

P3300T SS

Slots are
1 1/8" (29) x 9/16" (14)
2" (51) on Center

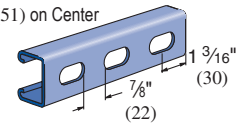

Wt/100 Ft: 130 Lbs (193 kg/100m)

P4000 SERIES

P4000 SS

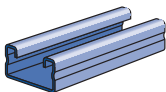

Wt/100 Ft: 82 Lbs (122 kg/100m)

P4000HS SS

9/16" (14) Dia. Holes
1 7/8" (48) on Center

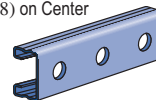

Wt/100 Ft: 79 Lbs (110 kg/100m)

P4000T SS

Slots are
1 1/8" (29) x 9/16" (14)
2" (51) on Center

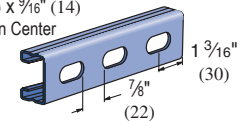

Wt/100 Ft: 79 Lbs (110 kg/100m)

P6000 SS

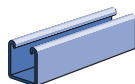

Wt/100 Ft: 37 Lbs (55 kg/100m)

P7000 SS

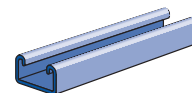

Wt/100 Ft: 36 Lbs (54 kg/100m)



P1184 SS

CLOSURE STRIP

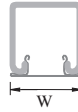
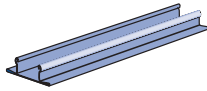

Standard length 10 Ft.
Material: Stainless steel type 304.

| Part Number | Use With Channel | "W" In (mm) | Wt/100 Ft Lbs (kg/m) |
|-------------|------------------|-------------|----------------------|
| P1184 SS | P1000 | | |
| | P1100 | 1½" | 27 |
| | P3300 | 41 | 40.2 |
| | P4000 | | |

CHANNEL NUT WITH SPRING— FOR USE WITH 1¼" CHANNEL

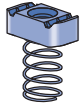
|  | Part number | Nut Size Thread | Wt/100 pcs Lbs (kg) | Use With |
|---|---------------|-----------------|---------------------|----------|
| | A1006-1420 SS | ¼" -20 | 6 (2.7) | A1000 |
| A1008 SS | ⅜" -16 | 6 (2.7) | | |

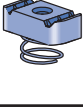
|  | Part number | Nut Size Thread | Wt/100 pcs Lbs (kg) | Use With |
|---|---------------|-----------------|---------------------|--------------|
| | A4006-1420 SS | ¼" -20 | 5 (2.3) | A3300, A4000 |
| A4008 SS | ⅜" -16 | 5 (2.3) | | |

* All Springs are Pre-Galvanized

CHANNEL NUT WITH SPRING – FOR USE WITH 1½" CHANNEL

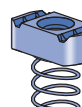
|  | Part number | Nut Size Thread | Wt/100 pcs Lbs (kg) | Use With 1½" Channel |
|---|----------------|-----------------|---------------------|----------------------------|
| | P1006U-1420 SS | ¼" 20 | 7 (3.2) | P1000, P1100, P2000, P3000 |
| | P1008U SS | ⅜" 16 | 10 (4.5) | |
| | P1010U SS | ½" 13 | 12 (5.4) | |

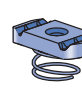
|  | Part number | Nut Size Thread | Wt/100 pcs Lbs (kg) | Use With 1½" Channel |
|---|----------------|-----------------|---------------------|----------------------|
| | P4006U-1420 SS | ¼" 20 | 7 (3.2) | P3300, P4000, P4100 |
| | P4008 SS | ⅜" 16 | 9 (4.1) | |
| | P4010 SS | ½" 13 | 9 (4.1) | |

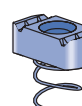
|  | Part number | Nut Size Thread | Wt/100 pcs Lbs (kg) | Use With 1½" Channel |
|---|----------------|-----------------|---------------------|----------------------|
| | P5506U-1420 SS | ¼" 20 | 7 (3.2) | P5500 |
| | P5508U SS | ⅜" 16 | 10 (4.5) | |
| | P5510U SS | ½" 13 | 10 (4.5) | |

* All Springs are Pre-Galvanized

The letter "U" in Part number = Sintered type 316 stainless steel

CHANNEL NUT WITHOUT SPRINGS – FOR USE WITH 1½" CHANNEL

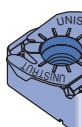
|  | Part number | Nut Size Thread | Wt/100 pcs Lbs (kg) | Use With 1½" Channel |
|---|----------------|-----------------|---------------------|----------------------------------|
| | P4006T-1420 SS | ¼" 20 | 7 (3.2) | P1000, P1100, P2000, P3000 P5500 |
| | P4008UT SS | ½" 13 | 12 (5.4) | |
| | P4010UT SS | ½" 13 | 8 (3.6) | P3300, P4000, P4100 |

The letter "U" in Part number = Sintered type 316 stainless steel

Note

Most fittings, as shown in this catalog are available in stainless steel or aluminum. It is recommended that stainless steel channel nuts be used with aluminum channels.

1½" Channel
 Telestrut System
 Hardware
 General Fittings
 Pipe/Conduit Supports
 Electrical Fittings
 Concrete Inserts
 1¼" Framing System
 1¾" Framing System
 Fiberglass System
 Special Metals
 PrimeAngle System
 Product Index

P1000 EA

 When used with P3184 EA.

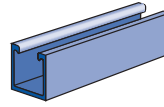
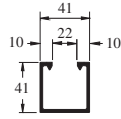
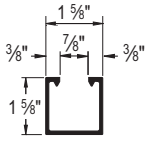

Wt/100 Ft: 76 Lbs (113 kg/100 m)
Aluminum Type 6063-T6
Nominal Thickness .109" (2.8mm)

P1001 EA

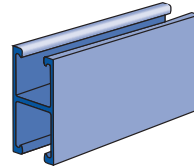
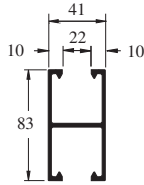
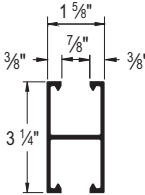

Wt/100 Ft: 134 Lbs (199 kg/100 m)
Aluminum Type 6063-T6
12 Gauge Nominal Thickness .109" (2.8mm)

P4000 EA

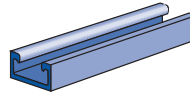
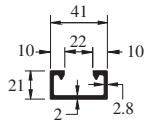
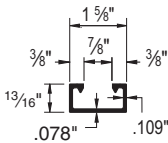

Wt/100 Ft: 45 Lbs (67 kg/100 m)
Aluminum Type 6063-T6
Nominal Thickness .078" (2.0mm)

P4001 EA

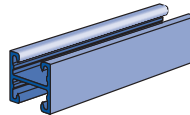
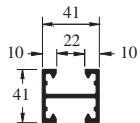
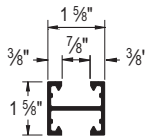

Wt/100 Ft: 66 Lbs (98 kg/100 m)
Aluminum Type 6063-T6
Nominal Thickness .078" (2.0mm)

P5500 EA

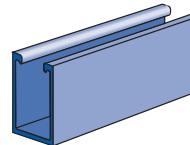
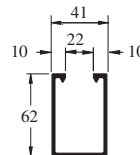
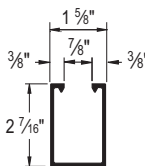

Wt/100 Ft: 97 Lbs (144 kg/100 m)
Aluminum Type 6063-T6
Nominal Thickness .109" (2.8mm)

A1000 EA

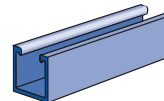
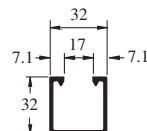
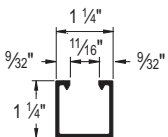

Wt/100 Ft: 40 Lbs (60 kg/100 m)
Aluminum Type 6063-T6
Nominal Thickness .075" (1.9mm)

A4000 EA

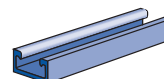
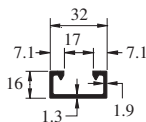
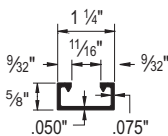

Wt/100 Ft: 25 Lbs (37 kg/100 m)
Aluminum Type 6063-T6
12 Gauge Nominal Thickness .050" (1.3mm)
Standard Length 16 Ft.



A4001 EA

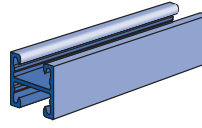
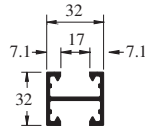
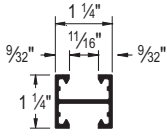

Wt/100 Ft: 40 Lbs (60 kg/100 m)
 Aluminum Type 6063-T6
 Nominal Thickness .078" (2.0mm)
 Standard Length 16 Ft.

P6000 EA

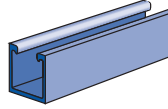
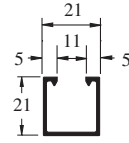
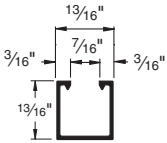

Wt/100 Ft: 12 Lbs (18 kg/100 m)
 Aluminum Type 6063-T6
 Nominal Thickness .040" (1.0mm)
 Standard Length 16 Ft.

P6001 EA

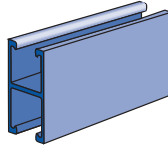
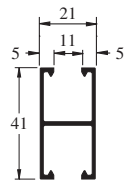
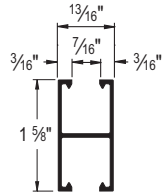

Wt/100 Ft: 20 Lbs (30 kg/100 m)
 Aluminum Type 6063-T6
 Nominal Thickness .040" (1.0mm)
 Standard Length 16 Ft.

P7000 EA

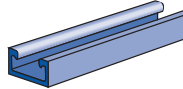
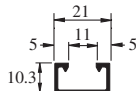
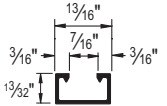

Wt/100 Ft: 9 Lbs (13 kg/100 m)
 Aluminum Type 6063-T6
 Nominal Thickness .040" (1.0mm)
 Standard Length 10 Ft.

P7001 EA

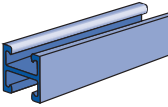
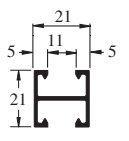
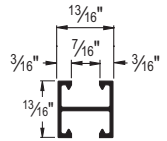

Wt/100 Ft: 17 Lbs (25 kg/100 m)
 Aluminum Type 6063-T6
 12 Gauge Nominal Thickness .040" (1.0mm)
 Standard Length 10 Ft

P3184 EA

CLOSURE STRIP

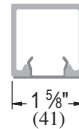
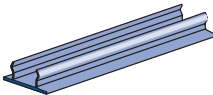

Wt/100 Ft: 21 Lbs (31 kg/100 m)
 Aluminum Type 6063-T6
 Standard Length 10 Ft

P1280 EA, P4280 EA, P5580 EA

END CAPS

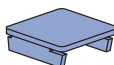

| Part Number | Use With Channel | Wt/100 Ft Lbs(kg/m) |
|-------------|------------------|---------------------|
| P1280 EA | P1000 EA | 3.5 (1.6) |
| P4280 EA | P4000 EA | 1.5 (0.7) |
| P5500 EA | P5500 EA | 4.9 (2.2) |

1 5/8" Channel
 Telestrut System
 Nuts & Hardware
 General Fittings
 Pipe/Conduit Supports
 Electrical Fittings
 Concrete Inserts
 1 1/4" Framing System
 1 3/16" Framing System
 Fiberglass System
 Special Metals
 PrimeAngle System
 Product Index

| | |
|----------------------------------|---------|
| PrimeAngle™ | 190 |
| Accessories | 191 |
| PrimeAngle™ Technical Data | 192-194 |

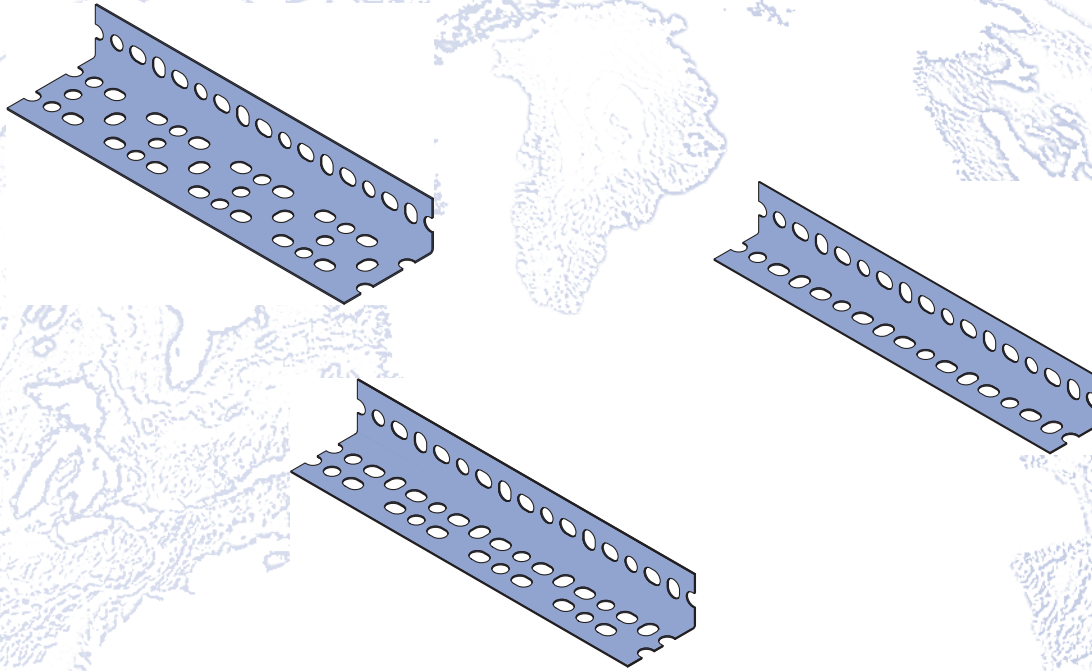

MATERIAL

STEEL: PLAIN

12 Gauge (.105" 1.0 mm) ASTM 1011 SS GR 33,
14 Gauge (.076) ASTM 1011 SS GR 33

STEEL: PRE-GALVANIZED

12 Gauge (.105" 1.0 mm) ASTM A653 GR 33,
14 Gauge (.076) ASTM A653 GR 33

FINISHES

Available in two durable, long-lasting finishes:

- Pre-Galvanized (PG) or
- Perma-Green III (GR) conforming to
ASTM B633 Type III SC1.

STANDARD LENGTHS

Standard lengths are 10' and 12'. Slotted angle is shipped in ten-piece bundles complete with 75 pieces of 3/8" - 16 x 3/4" hex head bolts and 3/8" nuts.

ORDERING INFORMATION:

When ordering, add the length or size and finish to the part number.

DIMENSIONS

Imperial dimensions are illustrated in inches. Metric dimensions are shown in parenthesis or as noted. Unless noted, all metric dimensions are in millimeters and rounded to one decimal place.



PA 158

(1⁵/₈" x 1⁵/₈" x 14 GA.) LIGHT DUTY

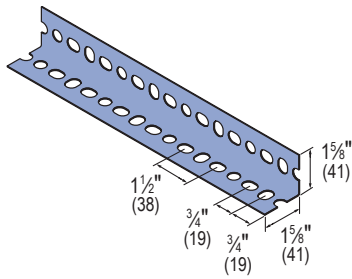

Note: Includes Serrated Nuts & Bolts

For those jobs where extra strength is not necessary. Ideal for light-duty shelving or racking.

Wt/100 Ft.: 66 lbs (29.9 kg)

PA 238

(1⁵/₈" x 2³/₈" x 14 GA.) MEDIUM DUTY

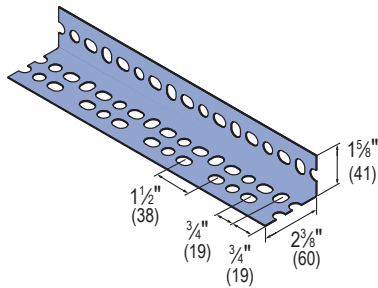

Note: Includes Serrated Nuts & Bolts

Perfect for the majority of framing needs, including shelving, racking and electrical or mechanical support jobs.

Wt/100 Ft.: 80 lbs(36.3 kg)

PA 318

(1⁵/₈" x 3¹/₈" x 12 GA.) HEAVY DUTY

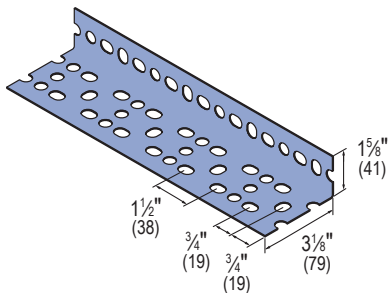

Note: Includes Serrated Nuts & Bolts

Suitable for balconies, ramps, large racks and shelving systems, as well as other structures with substantial load requirements.

Wt/100 Ft.: 130 lbs (59.0 kg)

PA 1HDC

PORTABLE CUTTER

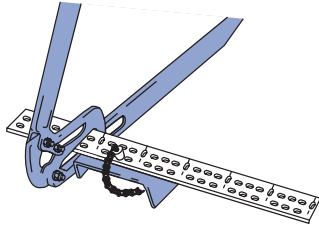

Wt/100 pcs: 17 lbs (7.7 kg)

PA 1GP

GUSSET PLATE

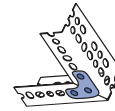

Wt/100 pcs: 9 lbs (4.1 kg)

PA 1SC

SWIVEL CASTER



Wt/100 pcs: 170 lbs (77.1 kg)

PA 1RC

RIGID CASTER



Wt/100 pcs: 110 lbs (49.9 kg)

PA 1SNB

SERRATED NUTS AND BOLTS

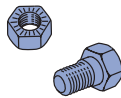

Wt/100 pcs: 7 lbs (3.2 kg)

PA 1RP

SLOTTED STRAP

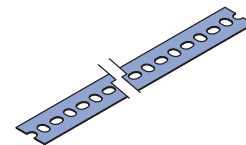

Wt/100 pcs: 35 lbs (15.9 kg)

TRANSVERSE STIFFENERS

When supporting concentrated loads, the capacity of a pair of slotted-angle beams can be increased by the addition of transverse stiffeners. These should be placed immediately under the load bearing point. The slotted-angle segment used as the stiffener is bolted into place using a metal connector at each junction.

Beams that are 6' (182.9 cm) long or less require only one stiffener in the center of the span. Seven-foot beams need two stiffeners placed 2' (61.0 cm) from each end. Eight-foot beams require two stiffeners 2'6" (76.2 cm) from the ends. For beams with a nine-foot span, it is necessary to have three stiffeners at 2'3" (68.6 cm) intervals. Ten-foot beams need three stiffeners with 2'6" spacings.

For maximum effectiveness, transverse stiffeners should never be spaced more than 3'6" (106.7 cm) apart.

Note: All loads based on actual physical testing. Documentation available on request.

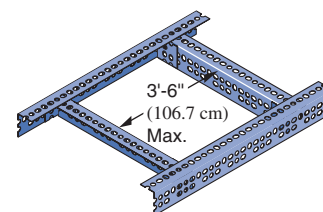



BEAM CONFIGURATIONS

(See corresponding letters in table on following page for load data)

G – Two Single Pieces (Up)

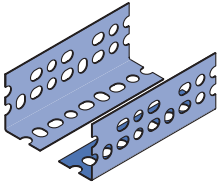

H – Two Single Pieces (Level)

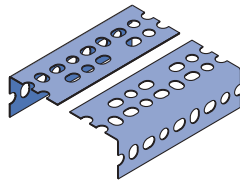

I – Two Single Pieces (Down)

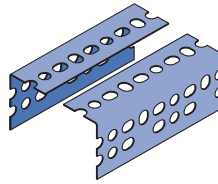

J – Two Z-Sections

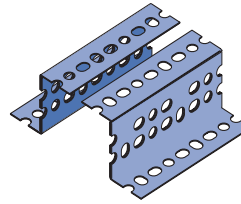

K – Two Narrow Channels

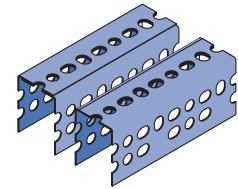

L – Two Broad Channels

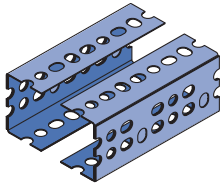

M – Two T-Sections

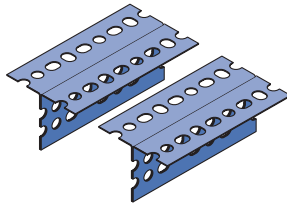

N – Two I-Section

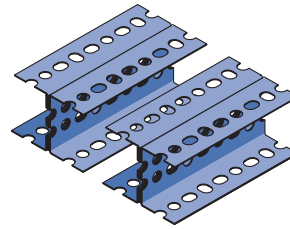

O – Two J-Sections

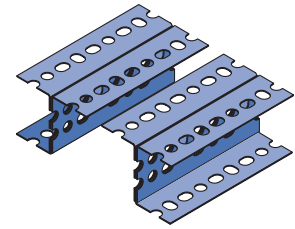

BEAM CONFIGURATIONS WITH STIFFENERS

(See corresponding letters in table on following page for load data)

P – Single Pieces w/Stiffener

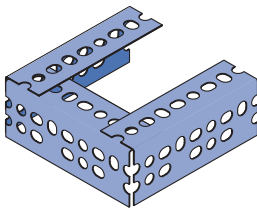

Q – T-Sections w/Stiffener

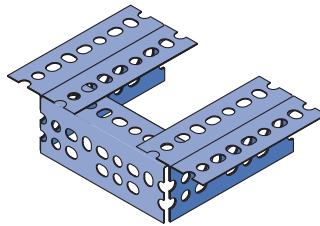

R – Z-Sections w/Stiffener

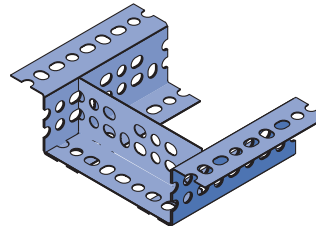

R – I-Sections w/Stiffener

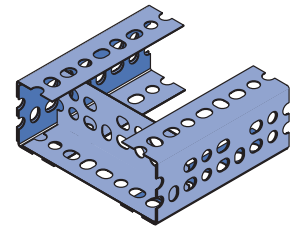

BEAM LOAD CALCULATIONS

The beam loading depends on which slotted angle is used and the manner in which the beam is constructed. The diagrams above show how individual slotted angle components can be combined to form a beam. The loading for each beam configuration is shown in the beam loading tables on the next page.

Example - Load "A"

Load "A" is supported by two 48" (121.9 cm) sections of PA-238 (1⁵/₈" x 2³/₈") (41mm x 60mm). The 48" row in the PA 238 table on next page indicates what each beam configuration will support. Since the columns are sorted from lowest to highest load, the first configuration that satisfies the requirement is "J" which will support 1,100 lbs (4.9 kN).

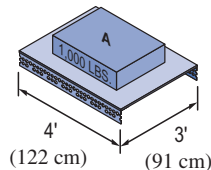

Example - Load "B"

Load "B" is supported by two 36" (91.4 cm) sections of PA-238 (1⁵/₈" x 2³/₈") (41mm x 60mm). The 36" row in the PA 238 table on next page indicates what each beam configuration will support. Since the columns are sorted from lowest to highest load, the first configuration that satisfies the requirement is "J" which will support 1,100 lbs (4.9 kN).

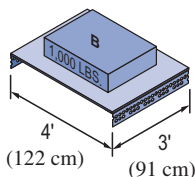

Example - Load "C"

Load "C" is supported by all four beam sections. The load is distributed uniformly on two 3' (91.4 cm) and two 4' (121.9 cm) beams which total 14' (426.7 cm) of supporting beam length. Dividing the 1,000 lbs. (4.5 kN) load by 14-feet equals 72 lbs. per foot (106.3 kg per meter). Using the two 4' (121.9 cm) longest (weakest) lengths, calculate the total weight as follows:

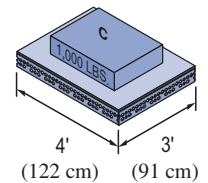

$$2 \text{ (beams)} \times 4' \text{ (length)} \times 72 \text{ lbs./ft.} = 576 \text{ lbs. total wt.}$$

$$2 \text{ (beams)} \times 121.9\text{cm (length)} \times 106.3 \text{ kg/M} = 25,915 \text{ kg total wt.}$$

The 36" (91.4 cm) row in the PA 238 table on next page indicates what each beam configuration will support. Since the columns are sorted from lowest to highest load, the first configuration that satisfies the requirement is "J" which will support 830 lbs. (3.7 kN) and is adequate for this requirement. The 3-foot beams configured in the same manner will support the load because they are shorter and stronger.

15/16" Channel
 Telestrut System
 Nuts & Hardware
 General Fittings
 Pipe/Conduit Supports
 Electrical Fittings
 Concrete Inserts
 1 1/4" Framing System
 1 3/4" Framing System
 Fiberglass System
 Special Metals
 PrimeAngle System
 Product Index

BEAM LOADS

(See corresponding letters in table on previous page for configurations)

PA 158

LIGHT DUTY, (1 5/8" x 1 5/8" x 14 GA.)

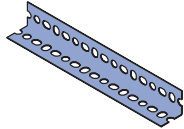

| Span In. (cm) | G Lbs (kN) | H Lbs (kN) | I Lbs (kN) | P Lbs (kN) | L Lbs (kN) | R Lbs (kN) | M Lbs (kN) |
|------------------|---------------|---------------|---------------|---------------|---------------|---------------|---------------|
| 24 | 550 | 830 | 830 | 920 | 1,600 | 1,700 | 1,840 |
| 61.0 | 2.4 | 3.7 | 3.7 | 4.1 | 7.1 | 7.6 | 8.2 |
| 36 | 370 | 560 | 560 | 610 | 1,070 | 1,130 | 1,230 |
| 91.4 | 1.6 | 2.5 | 2.5 | 2.7 | 4.8 | 5.0 | 5.5 |
| 48 | 280 | 420 | 420 | 460 | 800 | 850 | 920 |
| 121.9 | 1.2 | 1.9 | 1.9 | 2.0 | 3.6 | 3.8 | 4.1 |
| 60 | 220 | 330 | 330 | 370 | 640 | 680 | 740 |
| 152.4 | 1.0 | 1.5 | 1.5 | 1.6 | 2.8 | 3.0 | 3.3 |
| 72 | 180 | 280 | 280 | 310 | 530 | 570 | 610 |
| 182.9 | 0.8 | 1.2 | 1.2 | 1.4 | 2.4 | 2.5 | 2.7 |
| 84 | • | 240 | 240 | 260 | 460 | 490 | 530 |
| 213.4 | • | 1.1 | 1.1 | 1.2 | 2.0 | 2.2 | 2.4 |
| 96 | • | 210 | 210 | 230 | 400 | 430 | 460 |
| 243.8 | • | 0.9 | 0.9 | 1.0 | 1.8 | 1.9 | 2.0 |
| 108 | • | • | • | • | 360 | 380 | 410 |
| 274.3 | • | • | • | • | 1.6 | 1.7 | 1.8 |
| 120 | • | • | • | • | 320 | 340 | 370 |
| 304.8 | • | • | • | • | 1.4 | 1.5 | 1.6 |

PA 238

MEDIUM DUTY, (1 5/8" x 2 3/8" x 14 GA.)

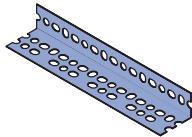

| Span In. (cm) | G Lbs (kN) | H Lbs (kN) | I Lbs (kN) | P Lbs (kN) | J Lbs (kN) | L Lbs (kN) | R Lbs (kN) | M Lbs (kN) | K Lbs (kN) | Q Lbs (kN) | O Lbs (kN) | N Lbs (kN) |
|------------------|---------------|---------------|---------------|---------------|---------------|---------------|---------------|---------------|---------------|---------------|---------------|---------------|
| 24 | 700 | 1,020 | 1,660 | 1,740 | 2,220 | 3,170 | 3,230 | 3,490 | 3,590 | 3,630 | 6,060 | 7,560 |
| 61.0 | 3.1 | 4.5 | 7.4 | 7.7 | 9.9 | 14.1 | 14.4 | 15.5 | 16.0 | 16.2 | 27.0 | 33.6 |
| 36 | 460 | 680 | 1,100 | 1,160 | 1,480 | 2,110 | 2,150 | 2,320 | 2,390 | 2,420 | 4,040 | 5,040 |
| 91.4 | 2.0 | 3.0 | 4.9 | 5.2 | 6.6 | 9.4 | 9.6 | 10.3 | 10.6 | 10.8 | 18.0 | 22.4 |
| 48 | 350 | 510 | 830 | 870 | 1,110 | 1,580 | 1,620 | 1,740 | 1,800 | 1,810 | 3,030 | 3,780 |
| 121.9 | 1.6 | 2.3 | 3.7 | 3.9 | 4.9 | 7.0 | 7.2 | 7.7 | 8.0 | 8.1 | 13.5 | 16.8 |
| 60 | 280 | 410 | 660 | 700 | 890 | 1,270 | 1,290 | 1,390 | 1,440 | 1,450 | 2,420 | 3,020 |
| 152.4 | 1.2 | 1.8 | 2.9 | 3.1 | 4.0 | 5.6 | 5.7 | 6.2 | 6.4 | 6.5 | 10.8 | 13.4 |
| 72 | 230 | 340 | 550 | 580 | 740 | 1,060 | 1,080 | 1,160 | 1,200 | 1,210 | 2,020 | 2,520 |
| 182.9 | 1.0 | 1.5 | 2.4 | 2.6 | 3.3 | 4.7 | 4.8 | 5.2 | 5.3 | 5.4 | 9.0 | 11.2 |
| 84 | • | 290 | 470 | 500 | 630 | 910 | 920 | 1,000 | 1,030 | 1,040 | 1,730 | 2,160 |
| 213.4 | • | 1.3 | 2.1 | 2.2 | 2.8 | 4.1 | 4.1 | 4.5 | 4.6 | 4.6 | 7.7 | 9.6 |
| 96 | • | 260 | 410 | 440 | 550 | 790 | 810 | 870 | 900 | 910 | 1,520 | 1,890 |
| 243.8 | • | 1.2 | 1.8 | 2.0 | 2.4 | 3.5 | 3.6 | 3.9 | 4.0 | 4.1 | 6.8 | 8.4 |
| 108 | • | • | • | • | 490 | 700 | 720 | 770 | 800 | 810 | 1,350 | 1,680 |
| 274.3 | • | • | • | • | 2.2 | 3.1 | 3.2 | 3.4 | 3.6 | 3.6 | 6.0 | 7.5 |
| 120 | • | • | • | • | 440 | 630 | 650 | 700 | 720 | 730 | 1,210 | 1,510 |
| 304.8 | • | • | • | • | 2.0 | 2.8 | 2.9 | 3.1 | 3.2 | 3.2 | 5.4 | 6.7 |

PA 318

HEAVY DUTY, (1 5/8" x 3 1/8" x 12 GA.)

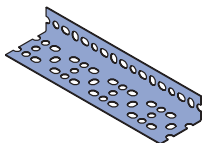

| Span In. (cm) | G Lbs (kN) | H Lbs (kN) | I Lbs (kN) | P Lbs (kN) | J Lbs (kN) | L Lbs (kN) | R Lbs (kN) | M Lbs (kN) | K Lbs (kN) | Q Lbs (kN) | O Lbs (kg) | N Lbs (kg) |
|------------------|---------------|---------------|---------------|---------------|---------------|---------------|---------------|---------------|---------------|---------------|---------------|---------------|
| 24 | 1,790 | 1,610 | 4,300 | 4,960 | 6,520 | 7,910 | 8,070 | 9,920 | 9,990 | 10,170 | 14,600 | 16,120 |
| 61.0 | 8.0 | 7.2 | 19.1 | 22.1 | 29.0 | 35.2 | 35.9 | 44.1 | 44.4 | 45.2 | 64.9 | 71.7 |
| 36 | 1,200 | 1,070 | 2,870 | 3,310 | 4,350 | 5,270 | 5,380 | 6,610 | 6,660 | 6,780 | 9,730 | 10,750 |
| 91.4 | 5.3 | 4.8 | 12.8 | 14.7 | 19.3 | 23.4 | 23.9 | 29.4 | 29.6 | 30.2 | 43.3 | 47.8 |
| 48 | 900 | 810 | 2,150 | 2,480 | 3,260 | 3,950 | 4,030 | 4,960 | 4,990 | 5,080 | 7,300 | 8,060 |
| 121.9 | 4.0 | 3.6 | 9.6 | 11.0 | 14.5 | 17.6 | 17.9 | 22.1 | 22.2 | 22.6 | 32.5 | 35.9 |
| 60 | 720 | 640 | 1,720 | 1,980 | 2,610 | 3,160 | 3,230 | 3,970 | 4,000 | 4,070 | 5,840 | 6,450 |
| 152.4 | 3.2 | 2.8 | 7.6 | 8.8 | 11.6 | 14.1 | 14.4 | 17.7 | 17.8 | 18.1 | 26.0 | 28.7 |
| 72 | 600 | 540 | 1,430 | 1,650 | 2,170 | 2,640 | 2,690 | 3,310 | 3,330 | 3,390 | 4,870 | 5,370 |
| 182.9 | 2.7 | 2.4 | 6.4 | 7.3 | 9.6 | 11.7 | 12.0 | 14.7 | 14.8 | 15.1 | 21.7 | 23.9 |
| 84 | • | 460 | 1,230 | 1,420 | 1,860 | 2,260 | 2,300 | 2,830 | 2,850 | 2,910 | 4,170 | 4,610 |
| 213.4 | • | 2.0 | 5.5 | 6.3 | 8.3 | 10.1 | 10.2 | 12.6 | 12.7 | 12.9 | 18.5 | 20.5 |
| 96 | • | 400 | 1,080 | 1,240 | 1,630 | 1,980 | 2,020 | 2,480 | 2,500 | 2,540 | 3,650 | 4,030 |
| 243.8 | • | 1.8 | 4.8 | 5.5 | 7.2 | 8.8 | 9.0 | 11.0 | 11.1 | 11.3 | 16.2 | 17.9 |
| 108 | • | • | • | 1,100 | 1,450 | 1,760 | 1,790 | 2,200 | 2,220 | 2,260 | 3,240 | 3,580 |
| 274.3 | • | • | • | 4.9 | 6.5 | 7.8 | 8.0 | 9.8 | 9.9 | 10.1 | 14.4 | 15.9 |
| 120 | • | • | • | 990 | 1,300 | 1,580 | 1,610 | 1,980 | 2,000 | 2,030 | 2,920 | 3,220 |
| 304.8 | • | • | • | 4.4 | 5.8 | 7.0 | 7.2 | 8.8 | 8.9 | 9.0 | 13.0 | 14.3 |



COLUMN LOADS

Column sections are calculated as described in the following example: (Assumes use of PA-238 1 5/8" x 2 3/8" (41mm x 60mm), material.)

Since all load areas are supported equally by the 4-columns, the calculations are based on a single-column section.

Section MN is one-fourth of "X", or 250 pounds (1.1 kN). Column section NP supports one-fourth of "Y" (250 pounds) plus the load supported by MN, or a total of 500 pounds (2.2 kN). Section PQ supports one-fourth of "Z" (250 pounds) plus the 500 pound load on section NP, or a total of 750 (3.3kN) pounds.

Column loads are based on free and unbraced column lengths. Since MN, NP and PQ are each 3' long, the load requirement is for a 36" section that will bear 750 pounds safely. A reference to the PA 238 table to the right indicates that all sections designated "A" will support 2,280 lbs. (10.1 kN) and meet the necessary requirements.

Note: To simplify assembly, we recommend using the same size material as for the horizontal members. This would be found in Table 2 to match the 14 gauge 1 5/8" x 2 3/8" (41mm x 60mm) material selected for the beams of this structure.

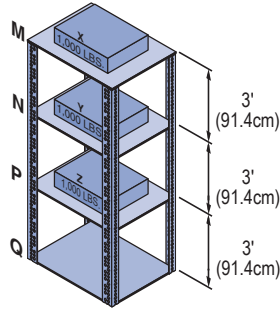

PA 158

(1 5/8" x 1 5/8" x 14 GA.)

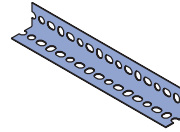

| Span In. (cm) | A Lbs (kN) | B Lbs (kN) |
|------------------|---------------|---------------|
| 36 | 1,450 | 3,850 |
| 91.4 | 6.5 | 17.1 |
| 48 | 1,150 | 3,500 |
| 121.9 | 5.1 | 15.6 |
| 60 | 950 | 3,000 |
| 152.4 | 4.2 | 13.3 |
| 72 | 750 | 2,500 |
| 182.9 | 3.3 | 11.1 |

PA 238

(1 5/8" x 2 3/8" x 14 GA.)

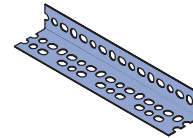

| Span In. (cm) | A Lbs (kN) | B Lbs (kN) | C Lbs (kN) | D Lbs (kN) | E Lbs (kN) | F Lbs (kN) |
|------------------|---------------|---------------|---------------|---------------|---------------|---------------|
| 36 | 2,280 | 4,760 | 4,940 | 7,270 | 9,520 | 9,865 |
| 91.4 | 10.1 | 21.2 | 22.0 | 32.3 | 42.3 | 43.9 |
| 48 | 1,970 | 4,490 | 4,680 | 6,920 | 8,970 | 9,330 |
| 121.9 | 8.8 | 20.0 | 20.8 | 30.8 | 39.9 | 41.5 |
| 60 | 1,520 | 3,995 | 4,310 | 6,370 | 7,990 | 8,620 |
| 152.4 | 6.8 | 17.8 | 19.2 | 28.3 | 35.5 | 38.3 |
| 72 | 1,070 | 3,140 | 3,870 | 5,840 | 6,280 | 7,715 |
| 182.9 | 4.8 | 14.0 | 17.2 | 26.0 | 27.9 | 34.3 |
| 84 | 660 | 2,340 | 3,665 | 4,930 | 4,660 | 6,740 |
| 213.4 | 2.9 | 10.4 | 16.3 | 21.9 | 20.7 | 30.0 |
| 96 | . | 1,750 | 2,700 | 3,850 | 3,500 | 5,365 |
| 243.8 | . | 7.8 | 12.0 | 17.1 | 15.6 | 23.9 |
| 108 | . | . | 2,060 | 2,870 | . | 4,115 |
| 274.3 | . | . | 9.2 | 12.8 | . | 18.3 |
| 120 | . | . | 1,610 | 2,690 | . | 3,210 |
| 304.8 | . | . | 7.2 | 12.0 | . | 14.3 |

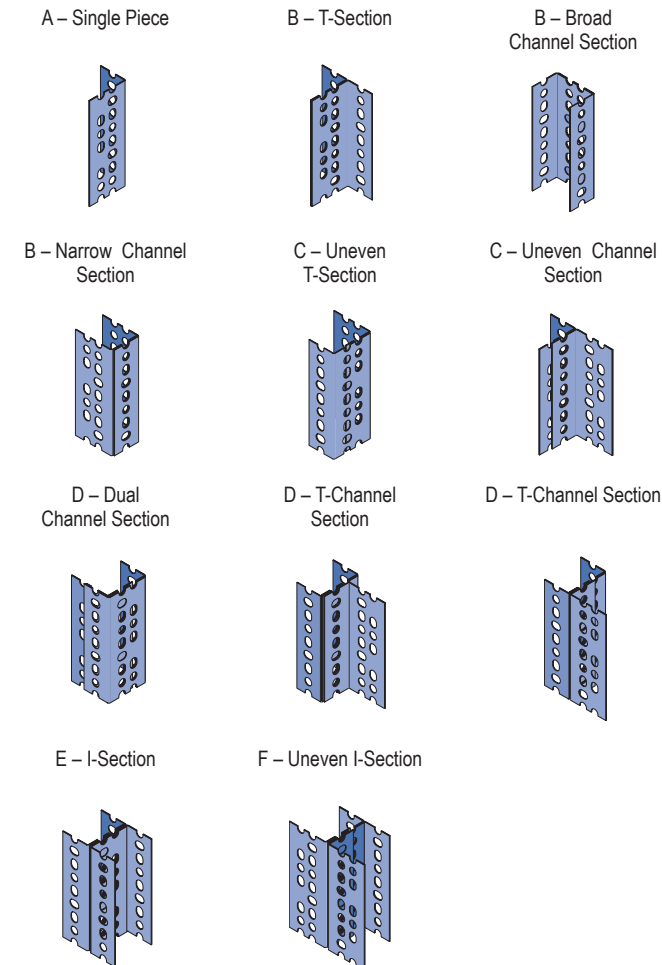

PA 318

(1 5/8" x 3 1/8" x 12 GA.)

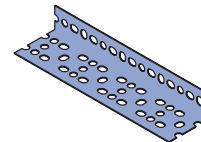

| Span In. (cm) | A Lbs (kN) | B Lbs (kN) | C Lbs (kN) | D Lbs (kN) | E Lbs (kN) | F Lbs (kN) |
|------------------|---------------|---------------|---------------|---------------|---------------|---------------|
| 36 | 3,470 | 7,970 | 8,770 | 12,560 | 15,940 | 17,550 |
| 91.4 | 15.4 | 35.5 | 39.0 | 55.9 | 70.9 | 78.1 |
| 48 | 2,870 | 7,360 | 8,580 | 11,970 | 14,750 | 17,150 |
| 121.9 | 12.8 | 32.7 | 38.2 | 53.2 | 65.6 | 76.3 |
| 60 | 1,970 | 6,570 | 8,180 | 11,360 | 13,160 | 16,360 |
| 152.4 | 8.8 | 29.2 | 36.4 | 50.5 | 58.5 | 72.8 |
| 72 | 1,280 | 5,270 | 7,690 | 10,480 | 10,560 | 15,360 |
| 182.9 | 5.7 | 23.4 | 34.2 | 46.6 | 47.0 | 68.3 |
| 84 | . | 3,670 | 6,970 | 9,470 | 7,370 | 13,970 |
| 213.3 | . | 16.3 | 31.0 | 42.1 | 32.8 | 62.1 |
| 96 | . | 2,580 | 6,260 | 8,370 | 5,170 | 12,570 |
| 243.8 | . | 11.5 | 27.8 | 37.2 | 23.0 | 55.9 |
| 108 | . | . | 5,460 | 6,880 | . | 10,970 |
| 274.3 | . | . | 24.3 | 30.6 | . | 48.8 |
| 120 | . | . | 4,460 | 5,370 | . | 8,960 |
| 304.8 | . | . | 19.8 | 23.9 | . | 39.9 |

1 5/8" Channel
 Telesnut System
 Nuts & Hardware
 General Fittings
 Pipe/Conduit Supports
 Electrical Fittings
 Concrete Inserts
 1 1/4" Framing System
 1 3/8" Framing System
 Fiberglass System
 Special Metals
 PrimeAngle System
 Product Index



| | |
|---|-----|
| 200-3100 thru 200-3140 | 177 |
| 004M007 thru 082M090 | 108 |
| 004T008 thru 022T026, 009N012 thru 106N114 | 107 |
| A1000 | 143 |
| A1000 EA | 187 |
| A1001 | 143 |
| A1001A | 144 |
| A1001B | 144 |
| A1001C | 144 |
| A1006-1420 | 150 |
| A1006-1420 SS | 186 |
| A1007 | 150 |
| A1008 | 150 |
| A1008 SS | 186 |
| A1026 | 151 |
| A1031 | 151 |
| A1033 | 152 |
| A1036 | 151 |
| A1037 | 152 |
| A1038 | 152 |
| A1045 | 152 |
| A1047 | 153 |
| A1063 | 151 |
| A1065 | 151 |
| A1066 | 151 |
| A1068 | 151 |
| A1184 | 151 |
| A1184P | 151 |
| A1191 | 151 |
| A1280 | 151 |
| A1325 | 152 |
| A1326 | 151 |
| A1331 | 152 |
| A1332 | 152 |
| A1357 | 152 |
| A1458 | 151 |
| A1579 | 152 |
| A2084 | 153 |
| A2109 | 153 |
| A2110 | 153 |
| A2111 | 153 |
| A2120 | 152 |
| A2125 | 153 |
| A2126 | 153 |
| A2127 | 153 |
| A2223 | 153 |
| A2227 | 153 |
| A2235 | 152 |
| A2324 | 151 |
| A2341 R-L | 153 |
| A2345 | 153 |
| A2472 R-L | 153 |
| A2494 R-L thru A2497 R-L | 154 |
| A2608 | 154 |
| A2608 thru A2617 | 154 |
| A2609 | 154 |
| A2611 | 154 |
| A2612 | 154 |
| A2613 | 154 |

| | |
|------------------|-----|
| A2614 | 154 |
| A2615 | 154 |
| A2617 | 154 |
| A3006-1420 | 150 |
| A3007 | 150 |
| A3008 | 150 |
| A3016-0832 | 150 |
| A3016-1024 | 150 |
| A3016-1032 | 150 |
| A3016-1420 | 150 |
| A3300 | 145 |
| A3301 | 145 |
| A3345 | 152 |
| A3347 | 153 |
| A4000 | 147 |
| A4000 EA | 187 |
| A4001 | 147 |
| A4001 EA | 188 |
| A4006-1420 | 150 |
| A4006-1420 SS | 186 |
| A4007 | 150 |
| A4008 | 150 |
| A4008 SS | 186 |
| A4045 | 152 |
| A4047 | 153 |
| A4120 | 152 |
| A4280 | 151 |
| A5000 | 149 |
| A5007 | 150 |
| A5043 | 153 |
| A5045 | 152 |
| A5047 | 153 |
| A5120 | 152 |
| A5280 | 151 |
| A5506-1420 | 150 |
| A5506-1420 SS | 186 |
| A5508 | 150 |
| A5508 SS | 186 |
| CG-10 thru CG-40 | 110 |
| F100-1500 | 178 |
| F100-1501 | 178 |
| F100-1502 | 178 |
| F100-1503 | 178 |
| F100-1504 | 178 |
| F100-1505 | 178 |
| F100-1506 | 178 |
| F100-1507 | 178 |
| F100-1508 | 178 |
| F100-1509 | 178 |
| F100-1510 | 178 |
| F100-1511 | 178 |
| F100-1512 | 178 |
| F100-1513 | 178 |
| F100-1514 | 178 |
| F1000E-999 | 173 |
| F10PU-CN | 172 |
| F10PU-CNMHD | 172 |
| F10PU-CNS | 172 |
| F12PU-CN | 172 |
| F12PU-CNMHD | 172 |

| | |
|-----------------|-----|
| F16PU-CNMHD | 172 |
| F200-3827 | 174 |
| F200-3828 | 174 |
| F200-3829 | 174 |
| F200-3830 | 174 |
| F200-3831 | 174 |
| F200-3840 | 174 |
| F200-3841 | 174 |
| F200-3842 | 174 |
| F200-3843 | 174 |
| F200-4101 | 178 |
| F200-4217 | 172 |
| F200-4219 | 172 |
| F200-4226 | 172 |
| F200-4227 | 172 |
| F200-4341 | 172 |
| F200-4342 | 172 |
| F200-4343 | 172 |
| F20E-5000 | 174 |
| F20N-ARM08 | 179 |
| F20N-ARM14 | 179 |
| F20N-ARM17 | 179 |
| F20N-ARM23 | 179 |
| F20N-STA21 | 179 |
| F20N-STA33 | 179 |
| F20P-2500 | 175 |
| F20P-2502 | 175 |
| F20P-2504 | 175 |
| F20P-2506 | 175 |
| F20P-2508 | 175 |
| F20P-2510 | 175 |
| F20P-2512 | 175 |
| F20P-2514 | 175 |
| F20P-2516 | 175 |
| F20P-2518 | 175 |
| F20P-2520 | 175 |
| F20P-2522 | 175 |
| F20P-2524 | 175 |
| F20P-2526 | 176 |
| F20P-2528 | 176 |
| F20P-2530 | 176 |
| F20P-2534 | 176 |
| F20P-2540 | 176 |
| F20P/V-1000 | 170 |
| F20P/V-1100 | 170 |
| F20P/V-1200 | 170 |
| F20P/V-1300 | 170 |
| F20P/V-2000 | 169 |
| F20P/V-2000 SST | 171 |
| F20P/V-2100 | 169 |
| F20P/V-2100 SST | 171 |
| F20P/V-2200 | 169 |
| F20P/V-2200 SST | 171 |
| F20P/V-2300 | 169 |
| F20P/V-2300 SST | 171 |
| F20PU-5853 | 176 |
| F20PU-5855 | 176 |
| F20PU-5903 | 176 |
| F20PU-5905 | 176 |
| F20PU-CNMHD | 172 |



| | |
|---------------|-----|
| F20V-2500 | 175 |
| F20V-2502 | 175 |
| F20V-2504 | 175 |
| F20V-2506 | 175 |
| F20V-2508 | 175 |
| F20V-2510 | 175 |
| F20V-2512 | 175 |
| F20V-2514 | 175 |
| F20V-2516 | 175 |
| F20V-2518 | 175 |
| F20V-2520 | 175 |
| F20V-2522 | 175 |
| F20V-2524 | 175 |
| F20V-2526 | 176 |
| F20V-2528 | 176 |
| F20V-2530 | 176 |
| F20V-2534 | 176 |
| F20V-2540 | 176 |
| F250E-999 | 173 |
| F250PU-000 | 173 |
| F250PU-075 | 172 |
| F250PU-100 | 172 |
| F250PU-150 | 172 |
| F250PU-CN | 172 |
| F312PU-CN | 172 |
| F375E-999 | 173 |
| F375PU | 179 |
| F375PU-000 | 173 |
| F375PU-125 | 173 |
| F375PU-150 | 173 |
| F375PU-200 | 173 |
| F375PU-250 | 173 |
| F375PU-300 | 173 |
| F375PU-BC | 179 |
| F375PU-CN | 172 |
| F375PU-CNHD | 172 |
| F375PU-FN-000 | 173 |
| F500E-999 | 173 |
| F500PU | 179 |
| F500PU-000 | 173 |
| F500PU-125 | 172 |
| F500PU-150 | 172 |
| F500PU-200 | 172 |
| F500PU-250 | 172 |
| F500PU-300 | 172 |
| F500PU-350 | 172 |
| F500PU-BC | 179 |
| F500PU-CN | 172 |
| F500PU-CNHD | 172 |
| F500PU-FN-000 | 173 |
| F50PU-1508 | 176 |
| F50PU-2008 | 176 |
| F50PU-2045 | 176 |
| F50PU-2090 | 176 |
| F50PU-2538 | 176 |
| F50PU-2611 | 176 |
| F50PU-2613 | 176 |
| F50PU-2616 | 176 |
| F50PU-2636 | 176 |
| F50PU-500SP | 173 |
| F625E-999 | 173 |
| F625PU-000 | 173 |
| F625PU-125 | 173 |
| F625PU-150 | 173 |

| | |
|----------------------------|-----|
| F625PU-200 | 173 |
| F625PU-250 | 173 |
| F625PU-300 | 173 |
| F625PU-350 | 173 |
| F625PU-CNHD | 172 |
| F625PU-FN-000 | 173 |
| F750E-999 | 173 |
| F750PU-CNHD | 172 |
| F750PU-FN-000 | 173 |
| FAIC-EC | 174 |
| FCVHPU-100 | 178 |
| FCVHPU-150 | 178 |
| FCVHPU-200 | 178 |
| FCVHPU-400 | 178 |
| FCVHPU-600 | 178 |
| FPCR-050 | 177 |
| FPCR-075 | 177 |
| FPCR-100 | 177 |
| FPCR-125 | 177 |
| FPCR-150 | 177 |
| FPCR-200 | 177 |
| FPCR-250 | 177 |
| FPCR-300 | 177 |
| FPCR-400 | 177 |
| FPCR-600 | 177 |
| FPCR-800 | 177 |
| FPS1000 | 177 |
| FPS1200 | 177 |
| FPS1400 | 177 |
| FPS1600 | 177 |
| FPS1800 | 177 |
| FPS200 | 177 |
| FPS250 | 177 |
| FPS300 | 177 |
| FPS350 | 177 |
| FPS400 | 177 |
| FPS500 | 177 |
| FPS600 | 177 |
| FPS800 | 177 |
| FRGBC | 179 |
| FUB-050 thru FUB-600 | 174 |
| HCSS025100EG | 68 |
| HFLW025EG | 69 |
| HFMS025062EG | 68 |
| HHCS025044EG | 68 |
| HHXN025EG | 69 |
| HLKW025EG | 69 |
| HOCW025 | 70 |
| HRCN025 | 69 |
| HRMS025050EG | 68 |
| HS025050EG | 68 |
| HSQN025EG | 69 |
| HTHR025 | 69 |
| J1205 N thru J 1280 N | 111 |
| J1205 thru J1280 | 111 |
| K1062 | 70 |
| K1063 | 70 |
| K1064 | 70 |
| LS 410-037 thru LS 410-075 | 100 |
| LS 500-037 thru LS 500-075 | 100 |
| LS 410 | 100 |
| M2037 | 127 |
| M2050 | 127 |
| M2137 | 127 |

| | |
|------------------|-----|
| M2150 | 127 |
| M2250 | 127 |
| M2350 | 127 |
| M24 | 138 |
| M2506 | 138 |
| M2508 | 138 |
| M2510 | 138 |
| M2512 | 138 |
| M2523 | 138 |
| M2524 | 138 |
| MU025 | 105 |
| MU025 thru MU400 | 105 |
| P1000 | 24 |
| P1000 DS | 24 |
| P1000 EA | 187 |
| P1000 H3 | 24 |
| P1000 HS | 24 |
| P1000 KO | 24 |
| P1000 SL | 24 |
| P1000 SS | 185 |
| P1000 T | 24 |
| P1000HS SS | 185 |
| P1000T SS | 185 |
| P1001 | 24 |
| P1001 3 | 27 |
| P1001 A | 27 |
| P1001 A3 | 27 |
| P1001 B | 27 |
| P1001 B3 | 27 |
| P1001 C | 27 |
| P1001 C3 | 27 |
| P1001 C41 | 27 |
| P1001 D3 | 27 |
| P1001 EA | 187 |
| P1001 SS | 185 |
| P1001 T | 27 |
| P1003 | 27 |
| P1004 A | 28 |
| P1006-0832 | 67 |
| P1006-1024 | 67 |
| P1006-1420 | 67 |
| P1006T1420 | 67 |
| P1006U-1420 SS | 186 |
| P1007 | 67 |
| P1008 | 67 |
| P1008T | 67 |
| P1008U SS | 186 |
| P1009 | 67 |
| P1010 | 67 |
| P1010T | 67 |
| P1010U SS | 186 |
| P1012 | 67 |
| P1012S | 67 |
| P1016 | 67 |
| P1023 | 67 |
| P1023S | 67 |
| P1024 | 67 |
| P1024S | 67 |
| P1026 | 76 |
| P1028 | 76 |
| P1029 | 78 |
| P1031 | 76 |
| P1033 | 77 |
| P1034 | 77 |

| | | | | | |
|-------------------------|-----|-------------------------|-----|---------------------|-----|
| P1035 | 78 | P1280 | 55 | P1734 | 80 |
| P1036 | 75 | P1280 A | 55 | P1736 | 80 |
| P1037 | 77 | P1280 EA | 188 | P1737 | 82 |
| P1038 | 77 | P1280W | 126 | P1747 | 77 |
| P1043A | 82 | P1281 | 76 | P1750 | 77 |
| P1044 | 82 | P1282 | 76 | P1753 | 122 |
| P1045 | 80 | P1283 | 76 | P1753 FG | 122 |
| P1046A | 82 | P1290 | 78 | P1753 PO | 122 |
| P1047 | 81 | P1291 | 78 | P1754 | 122 |
| P1048 | 82 | P1315 | 76 | P1754 FG | 122 |
| P1049 | 82 | P1320 | 81 | P1754 PO | 122 |
| P1050 | 82 | P1325 | 77 | P1769 | 84 |
| P1062 | 75 | P1326 | 77 | P1771 | 84 |
| P1063 | 75 | P1334 | 75 | P1773 | 85 |
| P1064 | 75 | P1346 | 77 | P1775 | 85 |
| P1065 | 75 | P1347 | 80 | P1777 | 85 |
| P1066 | 75 | P1354 | 98 | P1787 thru P1795 | 124 |
| P1067 | 75 | P1354A | 98 | P1796S | 92 |
| P1068 | 76 | P1356 | 76 | P1821 | 77 |
| P1075 | 85 | P1357 | 78 | P1822 | 77 |
| P1100 | 31 | P1358 | 76 | P1823 | 77 |
| P1100 HS | 30 | P1359 | 78 | P1834 | 96 |
| P1100 KO | 30 | P1363A thru P1363E | 81 | P1834A | 96 |
| P1100 SL | 30 | P1376 | 81 | P1843 | 98 |
| P1100 SS | 185 | P1376A | 81 | P1873 | 76 |
| P1100 T | 30 | P1377 | 81 | P1887 | 84 |
| P1100HS SS | 185 | P1379S | 94 | P1924 | 75 |
| P1100T SS | 185 | P1380 | 75 | P1925 | 75 |
| P1101 | 30 | P1380 A | 75 | P1934 | 78 |
| P1101 A | 30 | P1381 | 78 | P1941 | 75 |
| P1101 B | 30 | P1382 | 78 | P1944 | 97 |
| P1101 C | 30 | P1383 | 82 | P1950 | 76 |
| P1101 SS | 185 | P1386 | 94 | P1953 | 76 |
| P1109 | 102 | P1425 thru P1431 | 103 | P1956 | 78 |
| P1109 thru P1126 | 102 | P1453 | 80 | P1957 | 78 |
| P1111 | 102 | P1454 | 80 | P1959 | 75 |
| P1112 | 102 | P1455 | 81 | P1960 | 75 |
| P1113 | 102 | P1458 | 76 | P1961 | 75 |
| P1114 | 102 | P1479A thru P1479E | 80 | P1962 | 76 |
| P1115 | 102 | P1498 | 77 | P1964 | 75 |
| P1117 | 102 | P1499 | 77 | P1973 | 82 |
| P1118 | 102 | P1538A thru P1538D | 77 | P1985S | 94 |
| P1119 | 102 | P1546 | 79 | P1986S | 94 |
| P1120 | 102 | P1546, P2094 thru P2100 | 79 | P2000 | 34 |
| P1121 | 102 | P1563 thru P1573 | 103 | P2000 HS | 33 |
| P1123 | 102 | P1579 | 78 | P2000 KO | 33 |
| P1124 | 102 | P1593 | 85 | P2000 SL | 33 |
| P1126 | 102 | P1648S thru P1653S | 91 | P2000 T | 33 |
| P1130 | 79 | P1649AS | 91 | P2001 | 33 |
| P1131 | 79 | P1650AS | 91 | P2001 A | 33 |
| P1180 | 55 | P1651AS | 91 | P2001 B | 33 |
| P1180W | 126 | P1654 A | 91 | P2001 C | 33 |
| P1184 | 54 | P1654A thru P1661A | 91 | P2008 thru P2020 | 103 |
| P1184 P | 54 | P1690 thru P1697 | 123 | P2024 thru P2070-84 | 104 |
| P1184 SS | 186 | P16F | 128 | P2072 | 84 |
| P1186 | 79 | P1703 | 139 | P2072 SQ | 84 |
| P1186, P2105 thru P2110 | 79 | P1704 | 139 | P2072A | 84 |
| P1201 | 97 | P1713 | 78 | P2072A SQ | 84 |
| P1202 | 97 | P1723 | 76 | P2073 | 84 |
| P1203 | 97 | P1726 | 76 | P2073 SQ | 84 |
| P1204 thru P1208 | 97 | P1727 | 78 | P2073A | 84 |
| P1211 thru P1217 | 103 | P1728 | 78 | P2073A SQ | 84 |
| P1271S | 92 | P1730 | 80 | P2079 | 75 |
| P1272S | 94 | P1732 | 82 | P2094 | 79 |



| | | | |
|--|---|---|--|
| <p>1 5/8" Channel</p> <p>Telestrut System</p> <p>Nuts & Hardware</p> <p>General Fittings</p> <p>Pipe/Conduit Supports</p> <p>Electrical Fittings</p> <p>Concrete Inserts</p> <p>1 1/4" Framing System</p> <p>1 3/16" Framing System</p> <p>Fiberglass System</p> <p>Special Metals</p> <p>PrimeAngle System</p> <p>Product Index</p> | <p>P2095 79</p> <p>P2096 79</p> <p>P2097 79</p> <p>P2098 79</p> <p>P2099 79</p> <p>P2100 79</p> <p>P2101 thru P2104..... 79</p> <p>P2105 79</p> <p>P2106 79</p> <p>P2107 79</p> <p>P2108 79</p> <p>P2109 79</p> <p>P2110 79</p> <p>P21H.....128</p> <p>P2223 83</p> <p>P2224 83</p> <p>P2225 83</p> <p>P2226 83</p> <p>P2227 83</p> <p>P2228 83</p> <p>P2229 83</p> <p>P2230 83</p> <p>P2231 87</p> <p>P2231A..... 87</p> <p>P2232 87</p> <p>P2232A..... 87</p> <p>P2233 87</p> <p>P2233A..... 87</p> <p>P2234 87</p> <p>P2234A..... 87</p> <p>P2235 78</p> <p>P2237 82</p> <p>P2243 113</p> <p>P2245 83</p> <p>P2260 thru P2270..... 79</p> <p>P2280 55</p> <p>P2280 A 55</p> <p>P2280W.....126</p> <p>P2324 75</p> <p>P2325 75</p> <p>P2326 82</p> <p>P2328 82</p> <p>P2329 82</p> <p>P2341 R-L..... 83</p> <p>P2343 R-L..... 83</p> <p>P2344 R-L..... 83</p> <p>P2345 83</p> <p>P2346 83</p> <p>P2347 83</p> <p>P2348 84</p> <p>P2354 R-L..... 97</p> <p>P2355 R-L..... 97</p> <p>P2360 80</p> <p>P2378-1 68</p> <p>P2378-2 68</p> <p>P2378-3 68</p> <p>P2379-1 68</p> <p>P2379-2 68</p> <p>P2379-3 68</p> <p>P2380-1 68</p> <p>P2380-2 68</p> <p>P2380-3 68</p> <p>P2380-4 68</p> <p>P2380-5 68</p> | <p>P2380-6 68</p> <p>P2381-2 68</p> <p>P2381-3 68</p> <p>P2381-4 68</p> <p>P2381-5 68</p> <p>P2381-6 68</p> <p>P2381-7 68</p> <p>P2382-2 68</p> <p>P2382-3 68</p> <p>P2398S 91</p> <p>P2401S 91</p> <p>P2403S 91</p> <p>P2405S 91</p> <p>P2407 139</p> <p>P2426 thru P2431..... 105</p> <p>P2452 88</p> <p>P2453 84</p> <p>P2454 97</p> <p>P2458-18 thru P2458-36..... 88</p> <p>P2459-36 thru P2459-96..... 88</p> <p>P2469 80</p> <p>P2470-100..... 97</p> <p>P2470-50..... 97</p> <p>P2470-75..... 97</p> <p>P2471 75</p> <p>P2472 R-L..... 83</p> <p>P2473 82</p> <p>P2474 111</p> <p>P2474-1 112</p> <p>P2474-1 thru P2474-4..... 112</p> <p>P2474-2 112</p> <p>P2474-3 112</p> <p>P2474-4 112</p> <p>P2475 112</p> <p>P2476 112</p> <p>P2481 113</p> <p>P2482 113</p> <p>P2484 79</p> <p>P2484W..... 79</p> <p>P2485 70</p> <p>P2486 70</p> <p>P2490 75</p> <p>P2491 R-L thru P2493 R-L..... 85</p> <p>P2494 R-L thru P2499 R-L..... 86</p> <p>P2500 R-L thru P2503 R-L..... 86</p> <p>P2513 thru P2516..... 87</p> <p>P2513A thru P2516A..... 87</p> <p>P2521-100..... 126</p> <p>P2521-50..... 125</p> <p>P2521-75..... 125</p> <p>P2522 124</p> <p>P2534-50..... 123</p> <p>P2534-75..... 123</p> <p>P2535 124</p> <p>P2536 124</p> <p>P2537 125</p> <p>P2539 125</p> <p>P2540 126</p> <p>P2540A..... 126</p> <p>P2541 126</p> <p>P2542 thru P2546..... 86</p> <p>P2547 thru P2551..... 85</p> <p>P2552 127</p> <p>P2557 123</p> | <p>P2381-05 thru P2558-60..... 104</p> <p>P2567 123</p> <p>P2600 106</p> <p>P2602 125</p> <p>P2603 126</p> <p>P2609 thru P2617..... 105</p> <p>P2626 76</p> <p>P2645A thru P2645H..... 123</p> <p>P2647A 123</p> <p>P2647A thru P2647F..... 123</p> <p>P2647B 123</p> <p>P2647C 123</p> <p>P2647D 123</p> <p>P2647E 123</p> <p>P2647F..... 123</p> <p>P2649A thru P2649H..... 122</p> <p>P2655 97</p> <p>P2674 91</p> <p>P2675 89</p> <p>P2676 90</p> <p>P2677 90</p> <p>P2679-4..... 91</p> <p>P2682 90</p> <p>P2749 96</p> <p>P2749N..... 96</p> <p>P2750 96</p> <p>P2750N..... 96</p> <p>P2751 96</p> <p>P2751N..... 96</p> <p>P2755 125</p> <p>P2756 125</p> <p>P2757 125</p> <p>P2784-1..... 89</p> <p>P2785 92</p> <p>P2786 92</p> <p>P2787 92</p> <p>P2800 81</p> <p>P2801 126</p> <p>P2802 126</p> <p>P2803 126</p> <p>P2815 88</p> <p>P2815D..... 88</p> <p>P2820 130</p> <p>P2821 130</p> <p>P2822 130</p> <p>P2823 130</p> <p>P2824-12..... 92</p> <p>P2855 125</p> <p>P2856 125</p> <p>P2857 125</p> <p>P2859 55</p> <p>P2860 55</p> <p>P2862 75</p> <p>P2863 75</p> <p>P2864 75</p> <p>P2867 92</p> <p>P2867A..... 92</p> <p>P2867B..... 92</p> <p>P2868 93</p> <p>P2868A..... 93</p> <p>P2868B..... 93</p> <p>P2893 93</p> <p>P2894 93</p> <p>P2895 93</p> |
|--|---|---|--|

| | | | | | |
|------------------|-----|------------------|-----|------------------|-----|
| P2896 | 93 | P3253 | 136 | P3703 | 139 |
| P2897 | 89 | P3254 | 136 | P3704 | 139 |
| P2898 | 90 | P3255 | 136 | P3712 P | 54 |
| P2899 | 90 | P3256 | 136 | P3754 | 135 |
| P2900 | 127 | P3257 | 136 | P3922 thru P3926 | 125 |
| P2901 | 127 | P3257A | 136 | P4000 | 43 |
| P2902 | 127 | P3258 | 136 | P4000 EA | 187 |
| P2903 | 127 | P3259 | 136 | P4000 HS | 42 |
| P2904 | 127 | P3260 | 136 | P4000 SL | 42 |
| P2920 thru P2924 | 130 | P3261 | 136 | P4000 SS | 185 |
| P2928 | 130 | P3262 | 136 | P4000 T | 42 |
| P2929 | 130 | P3263 | 136 | P4000HS SS | 185 |
| P2930 | 130 | P3264 | 136 | P4000T SS | 185 |
| P2932 | 130 | P3265 | 136 | P4001 | 42 |
| P2940 | 130 | P3266 | 136 | P4001 EA | 187 |
| P2941 | 84 | P3267 | 136 | P4003 | 42 |
| P2942 | 84 | P3268 | 136 | P4004 | 42 |
| P2944 | 86 | P3269 | 136 | P4006-0832 | 67 |
| P2945 | 86 | P3270 | 136 | P4006-1024 | 67 |
| P2946 | 86 | P3280 | 139 | P4006-1420 | 67 |
| P2947 | 86 | P3280W | 126 | P4006-1420T SS | 186 |
| P2949 | 96 | P3300 | 40 | P4006U-1420 SS | 186 |
| P2950 | 96 | P3300 HS | 39 | P4007 | 67 |
| P3000 | 37 | P3300 SL | 39 | P4008 | 67 |
| P3000 HS | 36 | P3300 SS | 185 | P4008U SS | 186 |
| P3000 KO | 36 | P3300 T | 39 | P4008UT SS | 186 |
| P3000 SL | 36 | P3300HS SS | 185 | P4009 | 67 |
| P3000 SS | 185 | P3300T SS | 185 | P4010 | 67 |
| P3000 T | 36 | P3301 | 39 | P4010T | 67 |
| P3000HS SS | 185 | P3301 SS | 185 | P4010U SS | 186 |
| P3000T SS | 185 | P3301 T | 39 | P4010UT SS | 186 |
| P3001 | 36 | P3345 | 80 | P4012 | 67 |
| P3001 T | 36 | P3349 | 137 | P4012S | 67 |
| P3006-0832 | 67 | P3350 | 137 | P4023 | 67 |
| P3006-1024 | 67 | P3351 | 137 | P4023S | 67 |
| P3006-1420 | 67 | P3352 | 137 | P4043 | 82 |
| P3007 | 67 | P3353 | 137 | P4045 | 80 |
| P3008 | 67 | P3354 | 137 | P4047 | 81 |
| P3009 | 67 | P3355 | 137 | P4100 | 46 |
| P3010 | 67 | P3356 | 137 | P4100 HS | 45 |
| P3013 | 67 | P3357 | 137 | P4100 SL | 45 |
| P3016-0632 | 67 | P3357A | 137 | P4100 T | 45 |
| P3016-0832 | 67 | P3358 | 137 | P4101 | 45 |
| P3016-1024 | 67 | P3359 | 137 | P4101 T | 45 |
| P3016-1420 | 67 | P3360 | 137 | P4280 | 55 |
| P3045 | 80 | P3361 | 137 | P4280 EA | 188 |
| P3047 | 81 | P3362 | 137 | P4280W | 126 |
| P3087 | 94 | P3363 | 137 | P4376 | 81 |
| P3088 | 94 | P3364 | 137 | P4376A | 81 |
| P3116-125 | 127 | P3365 | 137 | P4377 | 81 |
| P3165 | 138 | P3366 | 137 | P4663 | 139 |
| P3170 | 138 | P3367 | 137 | P4703 | 139 |
| P3184 | 54 | P3368 | 137 | P4908 | 67 |
| P3184 EA | 188 | P3369 | 137 | P5000 | 49 |
| P3184 F | 54 | P3370 | 137 | P5000 HS | 48 |
| P3184 P | 54 | P3380 | 139 | P5000 KO | 48 |
| P3200 | 136 | P3409 thru P3417 | 105 | P5000 SL | 48 |
| P3245 | 138 | P3521-50 | 125 | P5000 T | 48 |
| P3245-N4 | 138 | P3539 | 125 | P5001 | 48 |
| P3245-N6 | 138 | P3663 | 139 | P5021-100 | 126 |
| P3249 | 136 | P3700 | 139 | P5077 | 81 |
| P3250 | 136 | P3700-37 | 139 | P5280 | 55 |
| P3251 | 136 | P3700-50 | 139 | P5280W | 126 |
| P3252 | 136 | P3700-62 | 139 | P5500 | 52 |



| | |
|----------------------------|-----|
| P5500 EA | 187 |
| P5500 HS | 51 |
| P5500 KO | 51 |
| P5500 SL | 51 |
| P5500 T | 51 |
| P5501 | 51 |
| P5501 T | 51 |
| P5506-0832 | 67 |
| P5506-1024 | 67 |
| P5506-1420 | 67 |
| P5506U-1420 SS | 186 |
| P5507 | 67 |
| P5508 | 67 |
| P5508U SS | 186 |
| P5509 | 67 |
| P5510 | 67 |
| P5510U SS | 186 |
| P5521-100 | 126 |
| P5537 | 125 |
| P5539 | 125 |
| P5543 | 82 |
| P5545 | 80 |
| P5547 | 81 |
| P5560 | 80 |
| P5577 | 81 |
| P5580 | 55 |
| P5580 EA | 126 |
| P5580W | 126 |
| P6000 | 157 |
| P6000 EA | 188 |
| P6000 SS | 185 |
| P6001 | 157 |
| P6001 EA | 188 |
| P6001A | 158 |
| P6001B | 158 |
| P6001C | 158 |
| P6006-0832 thru P6006-1420 | 161 |
| P6026 | 162 |
| P6028 | 162 |
| P6031 | 162 |
| P6033 | 162 |
| P6036 | 162 |
| P6037 | 163 |
| P6038 | 163 |
| P6044 | 165 |
| P6045 | 164 |
| P6047 | 164 |
| P6048 | 164 |
| P6062 | 161 |
| P6065 | 161 |
| P6066 | 161 |
| P6067 | 161 |
| P6068 | 162 |
| P6069 | 162 |
| P6127 thru P6129 | 165 |
| P6130 | 163 |
| P6184 P | 161 |
| P6186 | 164 |
| P6280 | 161 |
| P6281 | 162 |
| P6282 | 162 |
| P6283 | 162 |
| P6290 | 163 |
| P6291 | 163 |

| | |
|----------------------------|-----|
| P6325 | 162 |
| P6326 | 162 |
| P6331 | 163 |
| P6332 | 164 |
| P6334 | 162 |
| P6346 | 162 |
| P6347 | 164 |
| P6349 | 165 |
| P6353 | 165 |
| P6356A | 161 |
| P6357 | 163 |
| P6358A | 161 |
| P6359 | 163 |
| P6376 | 165 |
| P6376A | 165 |
| P6377 | 165 |
| P6379 S | 166 |
| P6380 | 162 |
| P6380A | 162 |
| P6381 | 163 |
| P6382 | 163 |
| P6386 | 166 |
| P6453 | 164 |
| P6454 | 164 |
| P6455 | 165 |
| P6458 | 162 |
| P6546 | 164 |
| P6579 | 163 |
| P6726A | 162 |
| P6728 | 163 |
| P6737 | 164 |
| P6758 | 164 |
| P6805 thru P6810 | 166 |
| P6887 | 163 |
| P6917 | 163 |
| P6918 | 163 |
| P6924 | 161 |
| P6925 | 161 |
| P6962 | 161 |
| P6973 | 165 |
| P7000 | 159 |
| P7000 EA | 188 |
| P7000 SS | 185 |
| P7001 | 159 |
| P7001 EA | 188 |
| P7006-0832 thru P7006-1420 | 161 |
| P7008 thru P7020 | 166 |
| P7045 | 164 |
| P7047 | 164 |
| P7048 | 165 |
| P7097 | 164 |
| P7098 | 164 |
| P7100 | 164 |
| P7101 | 164 |
| P7108 | 164 |
| P7109 | 164 |
| P7110 | 164 |
| P7235 | 163 |
| P7280 | 161 |
| P7324 | 161 |
| P7325 | 161 |
| P7347 | 164 |
| P7376 | 165 |
| P7376A | 165 |

| | |
|------------------------------|-----|
| P7377 | 165 |
| P7758 | 164 |
| P9000 | 59 |
| P9010 | 62 |
| P9011 | 62 |
| P9012 | 62 |
| P9013 | 63 |
| P9014 | 63 |
| P9200 | 59 |
| P9207 | 62 |
| P9209 | 62 |
| P9324 | 62 |
| PA 158 | 190 |
| PA 1GP | 191 |
| PA 1HDC | 191 |
| PA 1RC | 191 |
| PA 1RP | 191 |
| PA 1SC | 191 |
| PA 1SNB | 191 |
| PA 238 | 190 |
| PA 318 | 190 |
| PFL037 thru PFL050T | 95 |
| PFL2-37 | 89 |
| PLF3037 thru PLF3075 | 95 |
| PLF9037 thru PLF9100 | 95 |
| PLLC025 | 94 |
| PUX11810 | 110 |
| PUX11834 | 110 |
| PUX1234 | 110 |
| PUX13810 | 110 |
| PUX13834 | 110 |
| PUX15810 | 110 |
| PUX15834 | 110 |
| PUX21810 | 110 |
| PUX21834 | 110 |
| PUX23810 | 110 |
| PUX23834 | 110 |
| PUX25810 | 110 |
| PUX25834 | 110 |
| PUX31810 | 110 |
| PUX31834 | 110 |
| PUX3410 | 110 |
| PUX3434 | 110 |
| PUX35810 | 110 |
| PUX35834 | 110 |
| PUX3834 thru PUX41810 | 110 |
| PUX41834 | 110 |
| PUX5810 | 110 |
| PUX5834 | 110 |
| PUX7810 | 110 |
| PUX7834 | 110 |
| Slot Adapter™ | 70 |
| SPF 100-037 thru SPF 100-075 | 98 |
| SPF 200-037 thru SPF 200-075 | 98 |
| SPF 300-037 thru SPF 300-075 | 99 |
| SPF 400-037 thru SPF 400-075 | 99 |
| UB1/2PA | 109 |
| UP-BK thru UP-MPDS | 113 |
| UP-SPSS | 113 |

| | | | | | |
|--|----------|--|--------------------|--|---------|
| (1 ⁵ / ₈ " x 1 ⁵ / ₈ " x 14 ga.) Light Duty..... | 190 | Channel Nut With Spring.. | 67, 150, 161, 186 | End Cap for P7000..... | 161 |
| (1 ⁵ / ₈ " x 2 ³ / ₈ " x 14 ga.) Medium Duty | 190 | Channel Nut Without Spring | 67, 150, 186 | End Caps and Frame Caps | 55 |
| (1 ⁵ / ₈ " x 3 ¹ / ₈ " x 12 ga.) Heavy Duty..... | 190 | Channel Nuts, Caps & Closures | 161 | End Connector For 1" Conduit | 126 |
| "U" & Wing Shape Fittings..... | 82 | Channel Pictorial Index | 22 | End Connectors For 1/2" & 3/4" Conduit | 125 |
| "U" Shape & Special App. Fittings | 165 | Channel Selection Chart..... | 23 | End Connectors For 1/2"Conduit..... | 125 |
| "U" Shape Fittings..... | 81 | Channel Selection for Sch. 10 Sprinkler Pipe Trapeze Hangers..... | 116 | Extruded Aluminum Channels..... | 187-188 |
| "Z" Shape Fittings | 80 | Channel Selection for Sch. 40 Sprinkler Pipe Trapeze Hangers..... | 117 | Fabricated Clevis Hangers..... | 178 |
| 1/4" Framing System Pictorial Index | 142 | Channel Spacers | 173 | Fiberglass Beam Clamps, Power-Rack Stanchions | 179 |
| 1/4" x 1 1/2"..... | 145 | Channel Stud Nut With Spring | 68 | Fiberglass Channel Nuts & Accessories..... | 172 |
| 1/4" x 1 1/4"..... | 143 | Channel Trolley Support..... | 96 | Fiberglass Clamps Design Load Info..... | 180 |
| 1/4" x 2 1/2"..... | 144, 149 | Channel/Tube Connectors | 130 | Fiberglass Clevis Hangers | 178 |
| 1/4" x 3/4"..... | 145 | Channels & Combinations in Descending Order of Strength..... | 23 | Fiberglass Hardware | 173-174 |
| 1/4" x 5/8"..... | 147 | Chemical Compatibility Table | 180-181 | Fiberglass Pictorial Index..... | 168 |
| 13/16" Framing System Pictorial Index..... | 156 | Closure Strip..... | 151, 161, 186, 188 | Fiberglass Sample Specifications..... | 182 |
| 1 5/8" x 1 5/8" Channel..... | 136 | Closure Strips for 1 5/8" (41mm) Channel .. | 54 | Fiberglass Technical Data..... | 180-181 |
| 1 5/8" x 1 5/8" Channel..... | 135 | Column Insert | 94 | Fixture Stud Nut..... | 127 |
| 1 5/8" x 7/8" Channel..... | 138 | Column Loading..... | 28 | Fixture Wiring Nipple | 126 |
| 37 1/2° (.21ϖ) Stair Tread Support..... | 97 | Concrete Inserts Pictorial Index & Installation..... | 134 | Flange Clamp | 94-95 |
| 4" (101.6) Bus Bar Maple Clamps | 123 | Concrete Inserts Technical Data | 140 | Flat and 90° Fittings | 162 |
| 45° (.25ϖ) Stair Tread Support..... | 97 | Conduit Hanger Connection For 1/2" Conduit | 124 | Flat Fiberglass Fittings | 175 |
| 90° Rack Fitting | 130 | Conduit Hanger Connection For 3/4" Conduit | 124 | Flat Head Machine Screws | 68 |
| A1000 & A1001 Channels..... | 143, 144 | Conduit Supports..... | 119 | Flat Plate & 90° Angle Fittings..... | 76 |
| A3300 & A3301 Channels..... | 145-146 | Conduit Swing Fitting..... | 123 | Flat Plate Fittings..... | 75 |
| A4000 & A4001 Channels..... | 147-148 | Cone Point Set Screws..... | 68 | Flat Washers | 69,173 |
| A5000 Channels..... | 149 | Concrete Insert Load Chart | 140 | Fluorescent Fixture Hangers..... | 125 |
| Acetal Slide | 165 | Copper Tube (Type K)..... | 118 | Fluorescent Fixtures - Support Applications | 132 |
| Adjustable Hinge Connection | 98 | Copper Tube (Type L)..... | 118 | Frame Caps..... | 55 |
| Adjustable Brace Fitting | 88 | CUSH-A-CLAMP® Assembly | 107 | General Fittings Pictorial Index | 72-73 |
| Adjustable Pipe Clamps | 177 | CUSH-A-CLAMP Assembly Omega | 108 | Gravity Pin | 62 |
| Adjustable Seismic Pivot Fittings | 98 | CUSH-A-CLAMP Assembly U-Bolt..... | 109 | Gusset Plate..... | 191 |
| A-Konnector Rod Couplers | 174 | CUSH-A-GRIP®..... | 110 | Hardware | 68-70 |
| Alternate Three-Piece Assembly..... | 63 | CUSH-A-THERM™..... | 110 | Heavy Duty Back-to-Back Channel SST Profile..... | 171 |
| Angle and Wing Shape Fittings | 163 | Cutting Alignment Gauge | 62 | Heavy Duty Channel - Patented Flange Profile | 169 |
| Angle, "Z" & "U" Shape Fittings | 164 | Cutting Chart..... | 64 | Heavy Duty Channel Standard Profile..... | 171 |
| Angle, Wing and "U" Shape Fittings..... | 153 | Data for Schedule Steel Pipe..... | 120 | Heavy Duty Channel Nuts..... | 172 |
| Beam Clamps..... | 89-95 | Deck Insert..... | 139 | Heavy Duty Single Channel Patented Flange Profile | 169 |
| Beam Clamps and Tubing Clips..... | 166 | Deck Inserts..... | 139 | Heavy Duty Single Channel SST Profile..... | 171 |
| Beam Configurations With Stiffeners | 192 | Design Load Data..... | 74 | Hex Bolts..... | 173 |
| Beam Load Calculations..... | 192 | Double Pipe Axle Support | 97 | Hex Flange Bolts | 172 |
| Beam Loads | 193 | Duplex Grounded Receptacle | 123 | Hex Flange Nuts | 173 |
| Brace Fittings | 85-88 | Electrical Accessories & Junction Boxes | 126 | Hex Head Cap Screws | 68 |
| Brackets..... | 85, 165 | Electrical Fittings..... | 123, 124 | Hex Nuts | 173 |
| Cable Brackets | 130 | Electrical Fittings Pictorial Index | 122 | Hex Slotted Machine Screws..... | 68 |
| Cable Entrance Fittings..... | 130 | Electrical Metallic Tubing (EMT) - Thin Wall | 118 | Hexagon Nuts | 69 |
| Cable Entrance Tubing..... | 128-129 | Electrical Technical Data..... | 131-132 | High-Bay Fixture Raceway Applications . | 132 |
| Cable Saddles | 122 | End Caps..... | 139, 151 | Hold-Down Springs..... | 75 |
| Cable Tray Bracket..... | 85 | End Cap Anchors | 139 | Hub Assembly..... | 126 |
| Channel Capping Strip | 174 | End Cap for P6000..... | 161 | Installation and Heavy Duty Inserts..... | 135 |
| Channel End Cap..... | 174 | | | | |
| Channel End Caps, Closure Strips, Flat & 90° Fittings | 151 | | | | |
| Channel Fittings | 175 | | | | |
| Channel Nut Connection..... | 63 | | | | |
| Channel Nut Maximum Allowable Pull-out & Slip Loads..... | 66 | | | | |

15" Channel
 Telestrut System
 Nuts & Hardware
 General Fittings
 Pipe/Conduit Supports
 Electrical Fittings
 Concrete Inserts
 1 1/4" Framing System
 1 3/8" Framing System
 Fiberglass System
 Special Metals
 PrimeAngle System
 Product Index



| | | |
|--|--|---|
| <p>Installing Concrete Inserts 134</p> <p>Intermediate Metallic Conduit (IMC) 118</p> <p>J Conduit & Pipe Hanger 111</p> <p>Joint Covers 139</p> <p>Junction Box 126</p> <p>Junction Box Cover 126</p> <p>Knee Brace 88</p> <p>Kwik Washer™ 70</p> <p>Ladder Rung 97</p> <p>Lateral Bracing Load Reduction & Bearing Loads 56</p> <p>Light Duty 137</p> <p>Light Duty Channel Patented Flange Profile 170</p> <p>Light Duty Single Channel Patented Flange Profile 170</p> <p>Load Chart by Length 140</p> <p>Load Of Threaded Hot Rolled Steel 69</p> <p>Lock Washers 69</p> <p>Locking Clip 130</p> <p>Maple Cable Clamps 123</p> <p>Maple Cable Saddles 122</p> <p>Maximum Allowable Point Load 140</p> <p>Maximum Allowable Pull-Out & Slip Loads 150</p> <p>Maximum Allowable Pull-Out & Slip Loads 160</p> <p>Maximum Allowable Uniform Load 140</p> <p>Mecury Vapor Fixture Hanger 125</p> <p>Molded Beam Clamp Assembly 179</p> <p>Molded Beam Clamps 179</p> <p>Molded Clevis Hangers 178</p> <p>Multi-grip Rivet 62</p> <p>Mustang Universal One-Piece Pipe, Conduit (GRC, EMT & IMC) and Tubing Clamps 105</p> <p>Ninety Degree and "Z" Shape Fittings 152</p> <p>Ninety Degree Angle & Angular Fittings ... 79</p> <p>Ninety Degree Angle Fittings 77-78</p> <p>Nonmetallic U-Bolts 174</p> <p>Nut Selection and Load Data 150</p> <p>Nuts & Hardware Pictorial Index & Channel Nut Loads 66</p> <p>One Hole Clamp for O.D. Tubing 103</p> <p>Outlet Box 123</p> <p>Outlet Box Connection 124</p> <p>P1000 Channel Combinations 27-29</p> <p>P1000® & P1001 Channels 24-26</p> <p>P1100 & P1101 Channels 30-32</p> <p>P2000 & P2001 Channels 33-35</p> <p>P3000 & P3001 Channels 36-38</p> <p>P3300 & P3301 Channels 39-41</p> <p>P4000 & P4001 Channels 42-44</p> <p>P4100 & P4101 Channels 45-47</p> <p>P5000 & P5001 Channels 48-50</p> <p>P5500 & P5501 Channels 51-53</p> | <p>P5580 End Caps 126</p> <p>P6000 & P6001 Channel 157-158</p> <p>P7000 & P7001 Channel 159-160</p> <p>P9000 & P9200 Telestrut Channels 60-61</p> <p>Parallel Clamps for Rigid Conduit & Pipe 103</p> <p>Pipe & Conduit Clamps 103-105</p> <p>Pipe & Conduit Pictorial Index 102</p> <p>Pipe & Conduit Reference Data 114-120</p> <p>Pipe & Tubing Clamps 107-110</p> <p>Pipe Block 113</p> <p>Pipe Brackets 113</p> <p>Pipe Clamps 177</p> <p>Pipe Clamps for O.D. Tubing 104</p> <p>Pipe Clamps for Rigid Steel Conduit 102</p> <p>Pipe Clamps for Thin Wall Conduit (E.M.T.) 103</p> <p>Pipe Clips and Brackets 154</p> <p>Pipe Coupling Fitting 97</p> <p>Pipe Hangers 111</p> <p>Pipe Roller for ½" - 4" Pipe 111</p> <p>Pipe Roller for 1" - 24" Pipe 112</p> <p>Pipe Rollers 112</p> <p>Pipe Spacing Table 115</p> <p>Pipe Support Bracket 113</p> <p>Plastic White End Caps 55</p> <p>Polypropylene Wire Retainer 127</p> <p>Porce-A-Clamp™ 124</p> <p>Portable Cutter 191</p> <p>Post Bases & Telestrut Connection Methods, 63</p> <p>Power-Rack Stanchions 179</p> <p>Preferred Three-Piece Assembly 63</p> <p>Prime Angle and Accessories 190-191</p> <p>Prime Angle Beam Loads 192-193</p> <p>Prime Angle Column Loads 194</p> <p>Pull-Out Load 140</p> <p>Raceway Hangers 125</p> <p>Receptacles & Fixture Hangers 125</p> <p>Recommended Support Spacing for Fixtures 132</p> <p>Reel Rack Supports for 1¼" & 2" Pipe 97</p> <p>Retainer Strap 91</p> <p>Rigid Caster 191</p> <p>Rigid Pipe Clamps 177</p> <p>Rigid Steel (Heavy Duty) Conduit 119</p> <p>Round Head Machine Screws 68</p> <p>Saddle Clips 172</p> <p>Schedule 40: PVC Plastic Pipe 119</p> <p>Section Properties 169-170</p> <p>Seismic Pivot Fittings 98-100</p> <p>Seismic Retrofit Fittings 99-100</p> <p>Seismic Rod Stiffener 70</p> <p>Serrated Nuts and Bolts 191</p> <p>Single Piece Pipe Strap 104</p> | <p>Slot Adapter™ 70</p> <p>Slotted Channel 169-171</p> <p>Slotted Strap 191</p> <p>Spacer Clevis 126</p> <p>Spacing Chart 70</p> <p>Spacing of Multiple Point Loads 140</p> <p>Special Application Fittings 97</p> <p>Special Application Fittings & Seismic Retrofit Fittings 98</p> <p>Special Metals Pictorial Index 184</p> <p>Specialized Fittings & Post Bases 62</p> <p>Splice Fittings 125,130</p> <p>Spot Insert 138</p> <p>Spot Insert Load Chart 140</p> <p>Square Nuts 69</p> <p>Stainless Steel Channel 185</p> <p>Stainless Steel Channel Nuts & Closure Strips 186</p> <p>Standard Duty and Accessories 136, 138</p> <p>Standard Duty Channel Nuts 172</p> <p>Stand-off Pipe Clamps 105</p> <p>Steel Coupler Nuts 69</p> <p>Steel Threaded Rod 69</p> <p>Stop-Lock Assemblies 172</p> <p>Swiftgrip 89</p> <p>Swivel Caster 191</p> <p>Swivel Hangers & In-Channel Joiners 127</p> <p>Swivel Nut 91</p> <p>Telestrut Pictorial Index 58-59</p> <p>Threaded Rod 174</p> <p>Through-Bolt Connection 63</p> <p>Transverse Stiffeners 191</p> <p>Trolley Assemblies 96</p> <p>Tubing Clips 166</p> <p>Tubular Back Braces 88</p> <p>Tubular Knee Braces 88</p> <p>Two Hole Pipe Straps 177</p> <p>Two-Piece Assembly 63</p> <p>UNI-CLIP® & Support 105, 154</p> <p>UNICUSHION® 106</p> <p>UNICUSHION® Clamp Cutting Guide 106</p> <p>UNICUSHION® Clamp Selection Guide... 106</p> <p>UniPier™ 113</p> <p>Unisert Channel Insert 178</p> <p>Universal Beam Clamp 90</p> <p>Universal Clamps for Rigid or Thin wall Conduit 103</p> <p>Using Installed Concrete Insert 135</p> <p>Wall Ladder Bracket 97</p> <p>Wide Throat Beam Clamp 90</p> <p>Wing Shape Fittings 83</p> <p>Wing Shape Fittings, Post Bases & Brackets 84</p> <p>Wiring Stud Nut 126</p> |
|--|--|---|

UNISTRUT®

Application Showcase



The UNISTRUT® Metal Framing System

...engineered solutions you can count on!

Products of UNISTRUT are manufactured under one or more of the following United States patents:

| | | |
|-----------|-----------|-----------|
| 3,362,738 | 3,388,809 | 3,415,554 |
| 3,417,951 | 3,421,280 | 3,437,779 |
| 3,443,348 | 3,468,567 | 3,601,347 |
| 3,617,076 | 3,618,882 | 3,628,296 |
| 3,721,463 | 3,861,107 | 3,877,275 |
| 3,888,440 | 3,888,441 | 3,914,063 |
| 3,927,499 | 3,928,930 | 3,948,012 |
| 3,968,624 | 3,994,111 | 4,073,114 |
| 4,277,923 | 4,278,288 | 4,289,415 |

Foreign patents and other patents pending

THE PRODUCT APPLICATION SHOWCASE

Allows you to build a strong reputation with a World of Support from Unistrut. It's packed with examples and application photos of the Unistrut Framing System in action. Call for your copy today.

Registered Trademarks of UNISTRUT:

“AXENT”, “UNISTRUT”, “P1000”, “TELESPAR”, “TELESTRUT”, “UNI-CLIP”, “UNICUSHION”, “UNIROD”, “GRAB BAG”, “PRIME ANGLE”, “UniPier”, and the cartoon character “Mr. Strut”.

“SPF” is a Registered Trademark of Lord & Sons.

“Cush-A-Clamp”, “Cush-A-Grip”, & “Cush-A-Therm” is a Registered Trademark of ZSi.

Marketing throughout the world by Unistrut:
Tel: (800) 521-7730 • www.unistrut.com

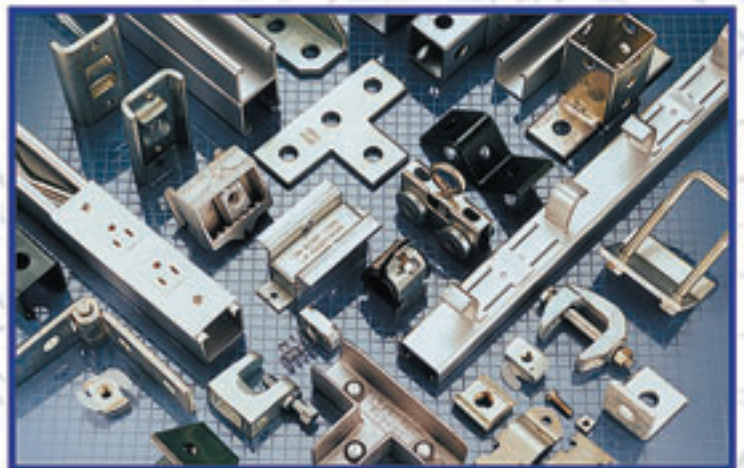

**When there's work to be done,
build with the leader...**

UNISTRUT®

UNISTRUT

4205 Elizabeth
Wayne, MI 48184
Phone: 800-521-7730
Fax: 734-721-4106

www.unistrut.com

UNISTRUT CANADA

585 Finley Avenue
Ajax, Ontario, L1S-2E4 Canada
Tel: (800) 267-4959 (Canada only)
Tel: (905) 683-8131
Fax: (905) 683-8987